

# TAKSTAR®

## 用户手册

### User's Manual

#### XR-612FX

**TAKSTAR®**

广东得胜电子有限公司

生产基地: 广东省惠州市博罗县龙溪镇龙桥大道

电话: 0752-6383951

传真: 0752-6383950

邮箱: XS@takstar.com

邮编: 516121

网址: www.takstar.com

Guangdong Takstar Electronic Co., Ltd.

Address: Longqiao Road Longxi Boluo Huizhou Guangdong China 516121

Tel: +86 752 6383644

Fax: +86 752 6383952

Email: sales@takstar.com

Website: www.takstar.com

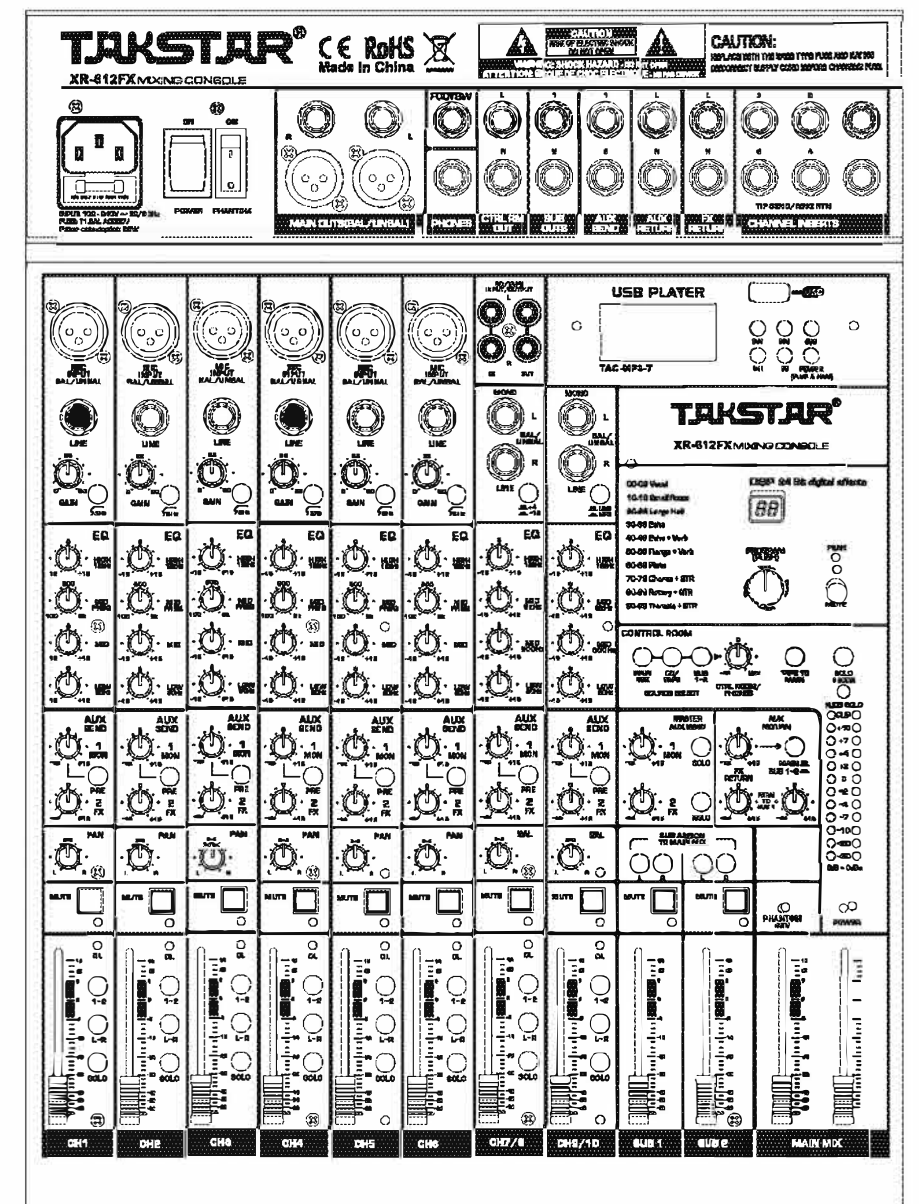



内部高压，小心触电



机器重要操作和维护提示

请阅读



保护接地端子



交流电流/电压



危险带电端

ON:

表示设备开启

OFF:

表示设备关闭

**警告**  
警示说明，需注意，  
避免可能受伤或死亡的危险。



**警告**  
警示说明，需注意以免造成产品  
损坏。产品的报废处理不能混于  
城市生活垃圾，需单独收集处理。

**警告**  
电源在接通机器电源之前，确保主电  
源电压与该机器所需电压一致，否则  
将对机器造成损坏或可能危害用户安  
全。机器长时间不用或打雷闪电时请  
拔出电源插头，以避免触电或火灾危  
险。

**外部连接**  
使用专用电源线连接，以免造成电  
击/死亡或火灾危险。若不明白，请联  
系技术人员处理。

**不要拆除任何外盖**  
机器内部有高压区，为了避免触电危  
险，在电源接通时不要拆除任何外盖  
。如有必要，请联系技术人员处理。

内部为非用户维修部件

**保险丝**  
为防止火灾及机器的损坏，确保使用  
指定规格保险丝，禁止使用不同规格  
保险丝。在换保险前，确保关闭机器  
电源，拔出电源插头。

**保护接地**  
开启机器前，确保与地连接，避免触电  
危险。严禁切断内部或外部的保护接地  
线或拔出保护接地端子。

**操作说明**  
请根据制造商的指示说明安装机器。  
为了避免触电和机器损坏，不要将机器  
置于雨水或潮湿环境。切勿在积水旁使  
用此机器。不要将机器安装于高温源附近  
不要阻塞任何通风口，以免引起火灾。  
机器远离明火。

**重要安全说明**  
-阅读安全说明  
-遵从安全说明  
-遵守安全说明  
-注意所有警示内容  
-只使用厂商指定配件

**电源线和插头**  
不要踩踏电源线或插头。  
不要断开保护接地连接。  
若提供的插头与您的AC座不配套，请联  
系技术人员更换电源插座。  
电源线与插头不要被重物压到以免有电击  
或火灾危险。

**清洁**  
当机器需要清洁时，可用吹风机或干净  
的布除去灰尘。  
不要使用清洁剂，如不纯苯、酒精等。  
为了安全，请保持机器干净。

**机器的维修**  
所有维修事项请询求专业技术人员帮助，  
非专业人员请不要擅自处理，以免造成触  
电危险。

**便携式推车  
使用警告**



**推车和支架**  
只使用制造商推荐  
的推车或支架。  
小心使用，快速停止  
用力过猛和地面不平  
可能造成机器和推车  
翻倒。

## TECHNICAL SPECIFICATION

Model Number		XR-612FX
Inputs Channel	Microphone Input	Electronically Balanced XLR Balanced
	Frequency Response	20Hz to 50KHz± 3dB
	Distortion (THD & N)	<0.005% to +4dBu, 1KHz
	Gain Range	0dBa50dB MIC
	SNR (Signal to Noise Ratio)	<-100dB
	Phantom Power	+48V with switch
	Line Input	Electronically Balanced 1/4" TRS
	Frequency Response	20Hz to 50KHz ±3dB
	Distortion	<0.005% to +4dBu, 1KHz
	Sensitivity	+15dBu ±3dB
Impedances	Microphone Input	1.4K Ohm
	All Other Inputs	10K Ohm
	Tape Out	1k Ohm
	All Other Output	120 Ohm
Equalization	Mono Channel	
	High	±15dB @ 12Khz
	Mid	±15dB Frequency Range 100Hz to 8KHz
	Low	±15dB@ 80Khz
	Stereo Channel	
	High	±15dB @ 12Khz
	High Mid	±15dB @ 3KHz
	Low Mid	±15dB @ 500hz
Low	±15dB @ 80Khz	
DSP Section	A/D & D/A Converters	24 Bit
	DSP Resolution	24 Bit
	Type of Effects	Vocal, Small Room, Large Hall, Echo, Echo+Verb, Flanger+Verb, Plate, Chorus GTR, Rotary GTR, Tremolo GTR
	Presets	100
	Controls	100 Position PRESET Selector (10 Presets,10 Variatios) *Mute* Switch with Indicator Light
	Main Mix Section	Bus Noise
Max. Output		+22dBu Unbalanced, 1/4" Jacks
Aux Sends Max. Outputs		+22dBu
Aux Returns Gain Range		-∞ to +15dB
USB Input	Builds in the USB full speed (12Mbps) Supports the USB mass storage class	
FAT Analysis	Supports FAT16 and FAT32 / Support VFAT (long file name)	
MP3 Decode	Supports Sample Rates 8KHz, 16KHz, 32KHz, 11.025KHz, 22.05KHz, 44.1KHz, 12KHz, 24KHz and 48KHz Supports bit rate 8 to 320 and VBR (Variable Bit rate) Except free format	
Electrical Specifications	Frequency Response	20Hz-20KHz
	Signal/Noise Ratio	>90dB
	1KHz Distortion	<0.04%
Power Supply	Main Voltage	100-240V~ 50/60Hz
	Fuse	1.6AL AC250V

## 目录 CONTENTS

1.简介.....	1
2.特性.....	1
3.控制单元.....	3
4.安装.....	14
5.连线.....	15
6.方块图.....	16
7.预设清单.....	18
8.技术规格.....	19
9.INTRODUCTION.....	20
10.FEATURES.....	20
11.HOOKUP DIAGRAM.....	21
12.CONTROL ELEMENTS.....	22
13.INSTALLATION TIPS.....	30
14.WIRE CONNECTIONS.....	31
15.BLOCK DIAGRAM.....	32
16.PRESET LIST.....	33
17.TECHNICAL SPECIFICATION.....	34

## 简介

感谢您购买TAKSTAR系列的产品,此为专业紧凑型调音台,能提供前所未有的品质和稳定性。本产品配有超低噪音前置放大器和+48V幻象电源,2个立体输入通道。每个立体通道包含暖音,平衡型EQ;2路输入,耳机/监听输出等。此外,还配有24字节的效果处理器。

请在使用此调音台之前阅读此说明书。

再次感谢您购买此调音台。

本产品可应用于以下环境中:家用;商用;大型集会;户外。此调音台不需使用rack架。其峰值电流是4.16A

## 特性

特点:

- 6个XLR和TRS平衡输入接口
- 立体声TRS平衡接口输入
- 增益控制和+48V幻像电源
- 单通道3段EQ,立体声4段EQ
- 2个辅助输送:辅助输送AUX1配有PRE/POST开关,用来切换不受推子控制或受推子控制,辅助输送AUX2受推子控制,可监听DSP效果
- 每个输入通道都有静音开关,监听开关及相对应的LED灯
- 通道配有SUB1~2和MAIN L-R分配开关
- CD/Tape IN可以配送到主输出或监听输出
- 监听有衰减前衰减后,两种不同方式的控制信号路径
- 平衡XLR和TRS输出
- 24字节的内部效果,配有100个预设,效果静音和峰值LED灯

## PRESET LIST

No.	Preset	Description	Parameter
00~09	Vocal	Simulate a small space with slight	Rev.delay time: 0.8~0.9s Pre-delay: 10~45ms
10~19	Small Room	Simulate a bright studio room	Decay time: 0.7~2.1s Pre-delay: 20~45ms
20~29	Large Hall	Simulate a large acoustic space	Decay time: 3.6~5.4s Pre-delay: 23~55ms
30~39	Echo	Echo/Delay effect	Delay time: 145~205ms
40~49	Echo+Verb	Echo & Reverb combination	Delay time: 208~650ms Decay time: 1.7~2.7s
50~59	Flanger+Verb	Flanger effect & Reverb combination	Decay time: 1.5~2.9ms Rate: 0.8Hz~2.52Hz
60~69	Plate	Simulate classic bright vocal plate	Decay time: 0.9s~3.6s
70~79	Chorus+GTR	Guitar Effect: Chorus	Rate:0.92Hz~1.72Hz
80~89	Rotary+GTR	Guitar Effect: Rotary	Modulation depth: 20%~80%
90~99	Tremolo+GTR	Guitar Effect: Tremolo	Rate : 0.6Hz~5Hz

# BLOCK DIAGRAM

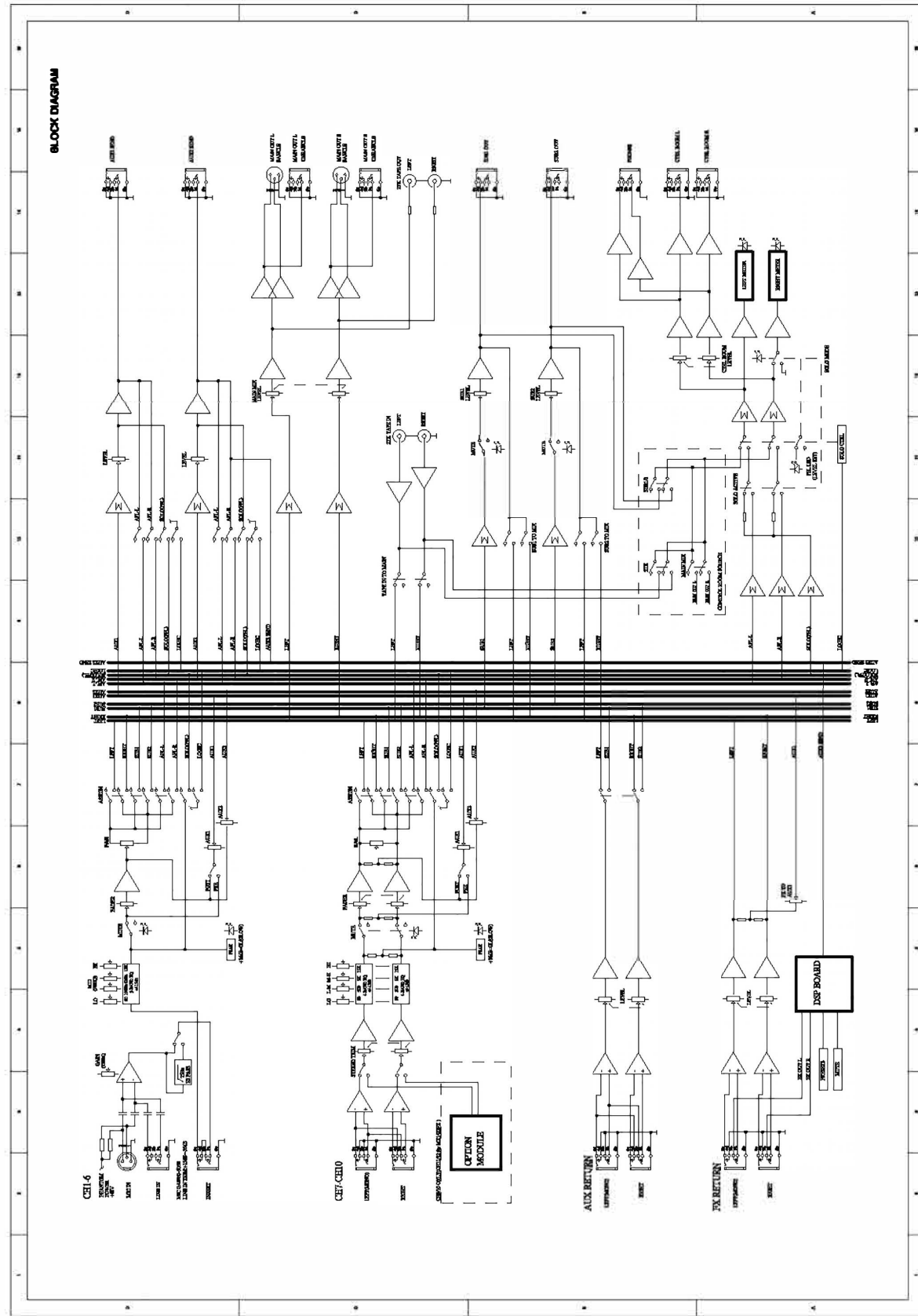

# 设备接线图

## 小型演出

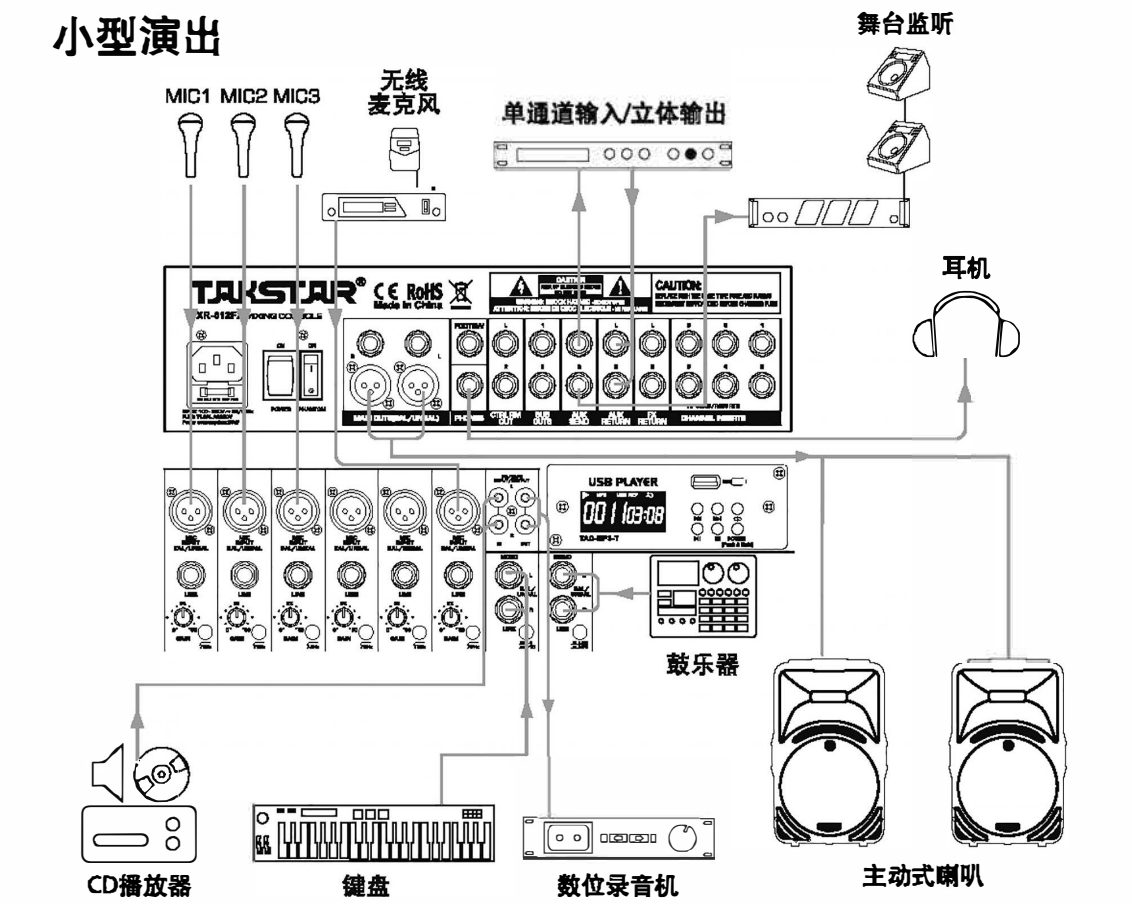

## 电脑连接

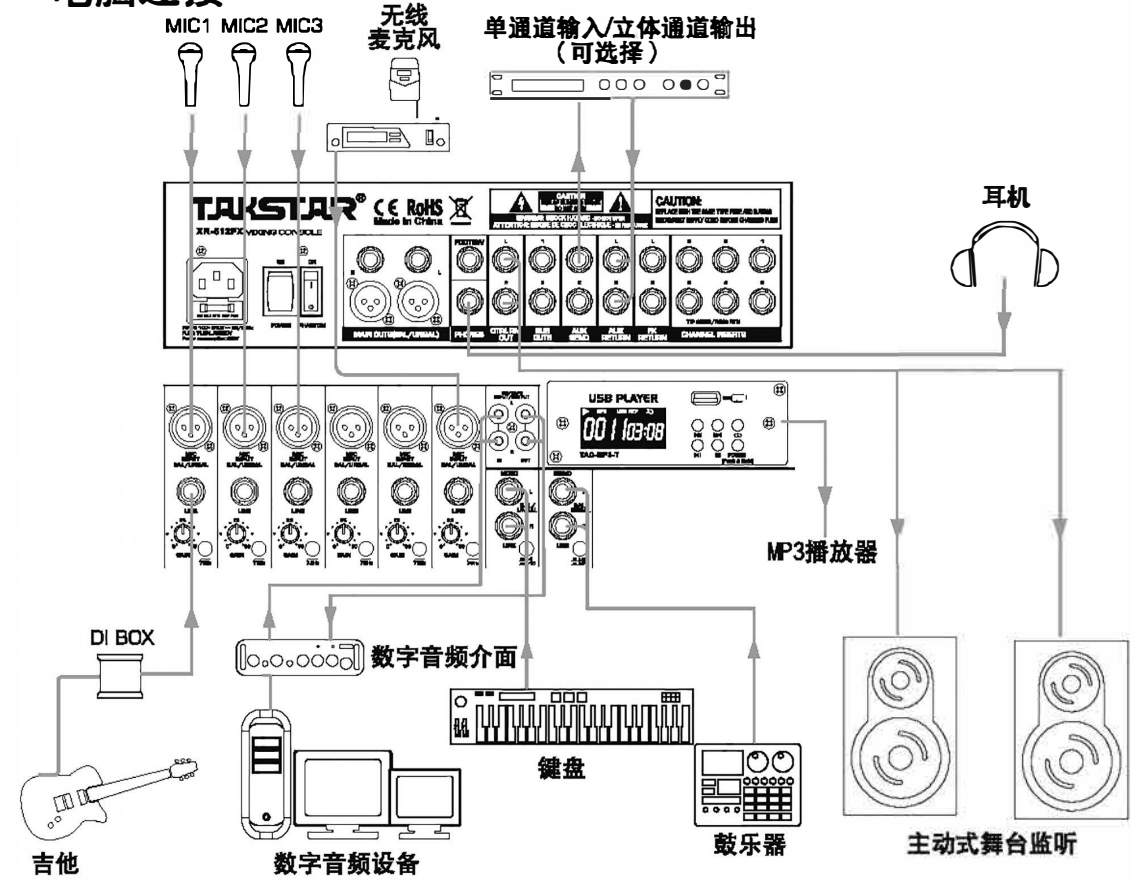

## 控制单元

### 前面板

#### 1. 单通道MIC输入：

TAKSTAR系列配有6个低噪音的前置放大器及幻象电源，可连接多种麦克风，无源麦克风不需要幻象电源，只有有源麦克风才需要幻象电源，在连接麦克风前，一定要确保幻象电源是开启的。在使用幻象电源前，一定要阅读操作说明。

TAKSTAR系列还配有1/4" TRS 平衡型插口和TS LINE IN非平衡型插口。

你可以将其与一些线性设备相连，例如合成器，键盘或效果设备。注意：在启动幻象电源后，不要将线性信号输入到XLR MIC输入，否则会对设备造成很大损伤。

#### 2. 立体线性输入：

配有1/4" TRS插口，可以与立体设备相连（包含有左右两个输入插口），如果将单通道信号输入到立体输入，就使用左边的输入，此时，信号就会出现在通道两边

#### 3. 增益旋钮：

增益控制旋钮是用来调节MIC和LINE输入的灵敏度的，调整范围为0dB~50dB

#### 4. 75Hz的低切开关

按此键启动75Hz的低频滤波，剪掉低于75Hz的频率。此开关可用于由于主电源引起的hum噪音或在使用麦克风时产生的隆隆响

#### 5. +4/-10开关

+4/-10开关是用来选择立体通道线性输入的灵敏度的。+4dBu适用于专业的音频设备，-10dBu适用于通用设备。如果不知道该选用哪个时，先用+4dBu，再试-10dBu

#### 6. 线性/MP3开关

按下开关，进入MP3模式，MP3信号会输送到相应通道或主混音通道。弹起开关，Line IN输入信号就会输送到Line输入通道。

#### 均衡器：

TAKSTAR系列单通道配有3段EQ，立体通道配有4段EQ，每段EQ范围为-15dB~+15dB。

#### 7. 高音旋钮：

此高音旋钮用来避免过高的人声。增益范围是-15dB~+15dB，中间频率是12kHz。

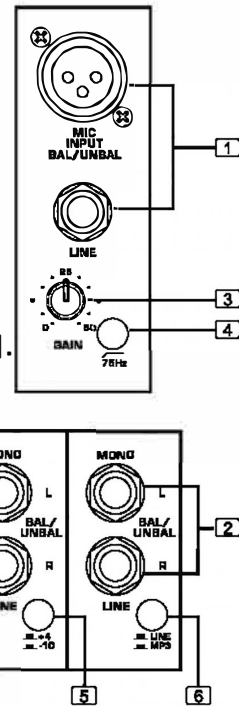

## WIRE CONNECTIONS

Either the 1/4" TRS phone jack or XLR connector can be wired in balanced and unbalanced modes, which will be determined by the actual application status, please wire your system as the following wiring examples:

#### • For 1/4" Phone jack

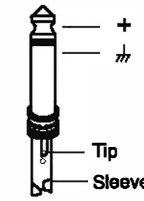

TS Type Unbalanced

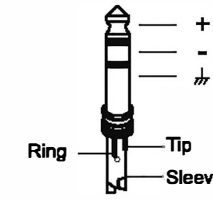

TRS Type Balanced

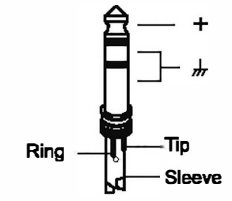

TRS Type Unbalanced

#### • For XLR Connector

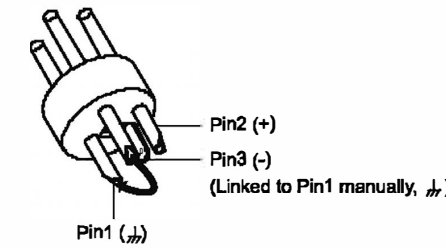

XLR Type Unbalanced

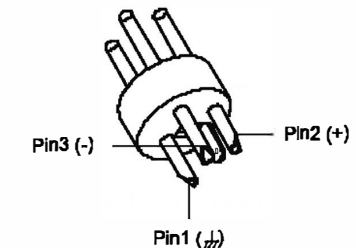

XLR Type balanced

#### In-line Connection

For these applications the unit provides 1/4" TRS and XLR connectors to easily interface with most professional audio devices. Follow the configuration examples below for your particular connection.

#### • Balanced

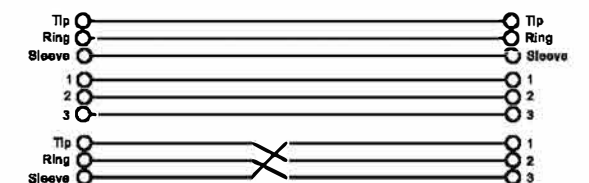
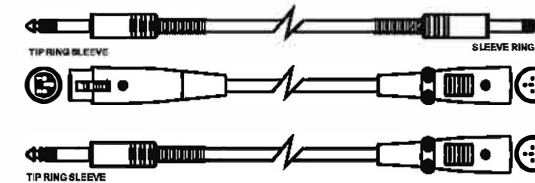

#### • Unbalanced

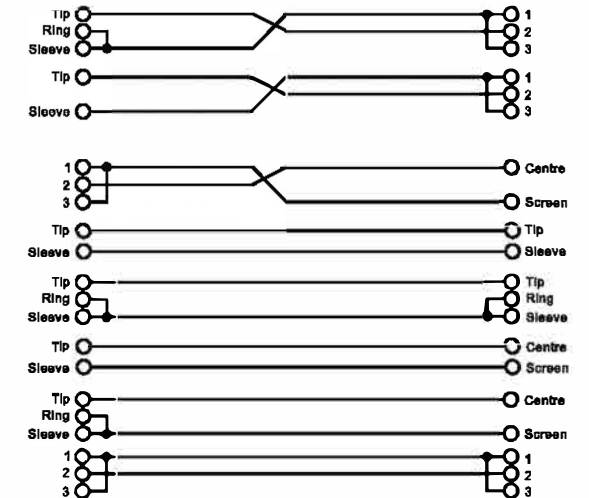
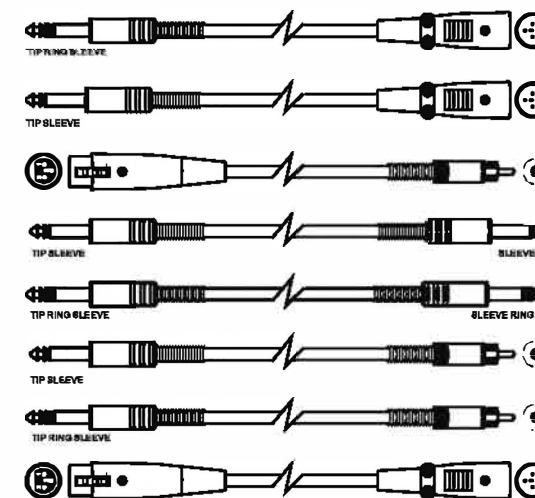

## INSTALLATION TIPS

- 1- Speakers should be placed in a position that allows for unobstructed sound projection. In many instances it is beneficial for speakers to be elevated on tripod stands to achieve maximum dispersion and reach.
- 2- Use professional advice or service when hanging and installing speakers. Please take precautions to secure them to prevent them from falling and hurting someone. Care should be taken as to not damage the cabinet or its components. Please comply with all pertinent Regulations.
- 3- Use quality cables. Using quality cables will ensure the best possible sound.
- 4- For best results match the speakers to a good amplifier that matches the wattage and impedance of your speakers. Proper amplification power results in good quality audio and longer component life. Check out the power requirement for your cabinet.
- 5- Avoid pointing a microphone directly at an amplified speaker doing so, could cause feedback possibly damaging speaker components and your hearing.

**Enjoy the sound!**

## 控制单元

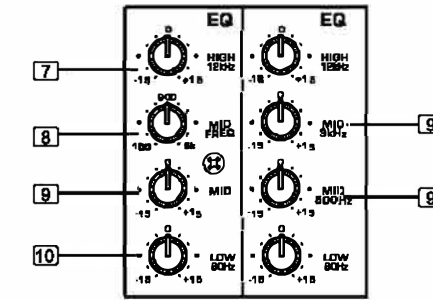

### 8. 中段频率旋钮

此旋钮可用于更改中段EQ过滤器中段频率。通过此旋钮，你可以精确的选择你所需要的频段。频段范围为100Hz~8kHz

### 9. 中音旋钮

该旋钮提供15dB的提升或衰减。在单通道有1个中音控制旋钮，在立体通道，有2个分离型中音控制旋钮，其中段频率为3kHz和500Hz。

### 10. 低音旋钮

此低音旋钮用来提升人声，乐器声。当使用该旋钮时，你听到的声音会比其实际声音要大。增益范围为-15dB~+15dB。中心频率是80Hz。

### 11. 辅助输送旋钮：

这两个旋钮用来调节输送到辅助总线1&2的信号，并且这个调整不会影响主输出的信号。辅助输送1可以当做PRE/POST推子使用。弹起为后置推子，信号会在通道推子后输出。按下为前推子，信号会在通道推子前输出，并且不会影响通道推子。AUX2可以当做后置推子。

### 12. 音场/平衡旋钮

在单通道是音场旋钮，在立体通道时是平衡旋钮。你可以通过此旋钮调整立体图像。音场控制旋钮用来调节声音在立体音场中的位置，旋钮转至中间位置，两边声音一致，旋钮转至最左时，声音在最左边，转至最右边时，声音在最右边

### 13. 静音开关：

每个通道都配有静音开关，按下此开关就相当于将推子调到最低，此开关可以使相应通道保持静音除了PFL模式下的监听功能，此外，静音LED灯也会亮

### 14. 监听开关和相应的LED灯

按下此键，相应的LED会亮，监听信号会取代其它信号到监听输出。通常使用监听功能是在使用mixer前做的一个检查，你可以同时使用多个通道的监听功能。

## 控制单元

### 15. 1-2&L-R开关

每个通道均有2个分配开关：1-2和L-R。按下1-2开关会将信号输送到SUB1-2，你也可以根据音场/平衡控制旋钮来调节输送到SUB1和SUB2的信号，将音场/平衡控制旋钮调到最左时，就会只有SUB1可以控制信号同样，按下L-R开关，信号可以输送到MAIN MIX L\_R,如果信号要完全输送到主输出，就必须按下此开关

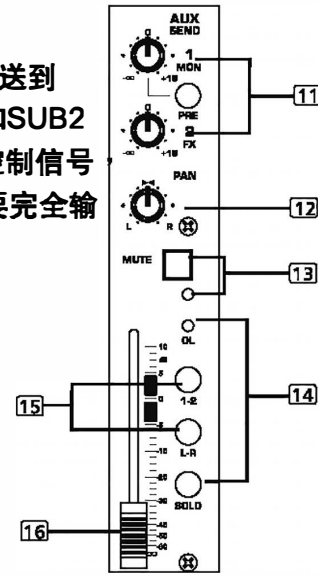

### 16. 推子：

用来调节每个通道的信号水平，将信号输送到主输出

### 17. SUB1-2分配到主混音开关

通过这些开关，你可以将SUB1-2推子当做主控制使用，它可以将SUB1-2信号输送到主混音。使用左开关，可以将相应SUB信号输送到主混音左，使用右开关，可以将相应SUB信号输送到主混音右，左右两开关都使用时，信号就可以输送到主混音的左和右

### 18.SUB1-2主推子

此推子用来控制输送到SUB1-2输出的信号，范围是-∞到+10dB

### 19. SUB1-2静音开关

按下此开关，相应通道就会静音

### 20.主混音推子

此推子用来控制主混音信号到主输出，磁带输出，监听输出，耳机输出和LED显示。注意，在连接喇叭功放前，请确保喇叭功放值准水平，以免造成损害。

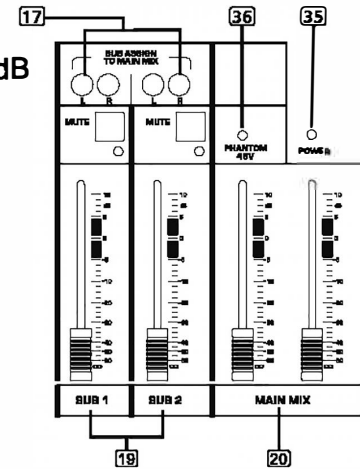

### 21.主辅助输送旋钮

此旋钮用来决定主辅助输送位准。调整范围是-到+15dB。当外接效果设备没有输入增益时，你还可以从AUX SEND 输出中多获得+15dB增益

### 22.主辅助输送监听开关

此开关用来监听输出和耳机输出的辅助信号

### 23.AUX/FX回程值准控制

此开关用来控制AUX/FX回程信号,这些信号会在主混音推子前增加到主混音总线的左右两端。如果没有从外部输入信号到FX 回程.这些信号就只会来自于内部效果模组,如果有加入一个外接效果处理器的话，内部效果就会断开,只有外接效果信号通过此旋钮控制

## CONTROL ELEMENTS

### Option Two - Track Module

The file system of USB memory for USB players is FAT16 and FAT32, and these players can only decode MP3. It has 7 rank subordinate folders at most.

#### 1- USB PORT

For connecting with USB memory.

#### 2- ⏮ PRE

In pause state, press this key, it will go to previous track and keep in pause state. In play state, press this key, it will go to the previous track & start playing.

#### 3- ⏭ NEXT

In pause state, press this key, it will go to next track and keep in pause state. In play state, press this key, it will go to the next track and start playing.

#### 4- ⏮ RPT

Press this key, the player will change between the following four modes: REP ALL means to repeat all tracks in the memory, mark on the screen is REP1 means to repeat one track, the mark on the screen is

Play in order means to play the tracks according to the order, the mark on the screen is blank. Random play means to play the tracks at random, the mark on the screen is A

#### 5- ⏮ PLAY/PAUSE

In play state, press PLAY/PAUSE key to pause the player. In pause state, press PLAY/PAUSE key to start playing.

#### 6- ■ STOP

In play state, press this key to stop playing and all the songs in USB memory will appear on the display; In stop state, press STOP/⏮PRE/⏭NEXT keys again to go to first song and the player will keep in pause state, then press PLAY/PAUSE key to play the song.

#### 7-POWER(Push & Hold)

When the unit is off, press this key and hold for about 2 or 3 seconds to turn on the power supply of the player. Repeat the above operation, you can turn off the power supply of the player.

#### 8- DISPLAY: All MP3 player information are monitored via this sexy & magic display.

#### NOTE: basic interface instruction

When the player isn't connected to a USB memory equipment, the interface is as follows:

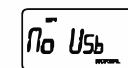

When the player is searching for USB tracks, the interface is as follows:

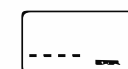

When the player is in pause state, the interface is as follows:



When the player is in use, the interface is as follows:

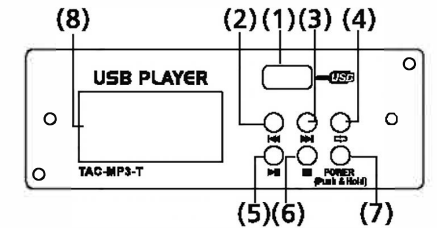



## CONTROL ELEMENTS

### 46- SUB OUTS

These 1/4" jacks are unbalanced outputs. The signal level to the SUBOUT is adjusted by SUB1-2 knob on the front panel.

### 47- AUX SEND OUT

These 1/4" TRS are used to send out the signal from the AUX bus to external device such as effects equipment, they also can be used as monitoring outputs by connecting a power amplifier and monitor speaker. Each channel has an AUX SEND 1 MON and AUX SEND 2 FX control that adjusts how much of that channel's signal appear at each of these outputs.

### 48- STEREO AUX RETURN Inputs

Use these stereo 1/4" jacks to return the signal of an effect unit to main mix. The level controlled by Master AUX RETURN knob. Only use the left input if connect a mono input signal to the AUX RETURN inputs, the signal will appear on both sides.

### 49- STEREO FX RETURN Inputs

Connect these inputs with the output of an external effects device. If you plugging a 1/4" jack into these inputs, it will disconnect the internal effects processor. However, if you plug into just the left input, the right internal effects is still connected, and vice versa. The signal is routed to main mix, the level controlled by FX RETURN knob.

### 50- 1/4" MAIN OUT Jacks

These 1/4" TRS jacks are used to connect with the inputs of an external amplifiers or active speakers. It has the same signal that appears at the XLR MAIN OUTS on the rear panel.

### 51- CHANNEL INSERTS 1-6

Insert sockets are provided for all mono MIC channels. It can allow you patch external processing devices into signal path via a TRS connector, the signal will be taken out after the input gain control, and sent to an external processor such as a compressor-limiter, then returned into the same channel immediately before the EQ section.

## 控制单元

### 24. 主混音/SUB 1-2开关

此开关弹起，就会将信号从辅助回程输送到主混音主线，按下此开关，立体信号就会被输送到SUB1-2总线。

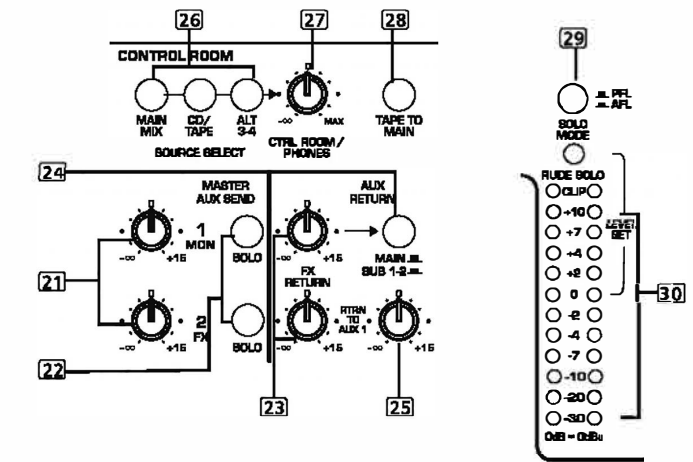

### 25. RTRN到AUX1位准控制

此开关将出现在FX RETURN插口的信号输送到AUX1输出，这样效果就可以在监听输出处听到

### 26. 监听开关

通过此开关可以监听主混音，CD/磁带，SUB 1-2的信号结合，相应的立体信号也会输送到控制室/耳机输出和LED灯

### 27. 监听/耳机监听输出，增益控制旋钮

此开关用来调节监听输出/耳机输出的信号水准

### 28. TAPE到Main开关

按此开关可以将CD/磁带信号输送到主混音，也可通过主混音开关调节音量水准。

### 29. 监听模式和监听 LED

按下此键，会将衰减前信号更换成衰减后信号，衰减后信号则会被输送到监听输出，耳机输出和右LED灯显示（当在衰减后监听模式下有左右LED灯之分）。

监听信号水准是由监听/耳机旋钮控制。此按键提供两种模式，弹起是衰减后模式，按下是衰减前模式，但不论在哪个模式，监听信号水准不会受MUTE/ALT开关影响。

### 30. LED指示灯

这些立体LED电平会显示整个输出信号的水准

### 31. 预设显示

显示你所选择的预设。

## 控制单元

### 32.效果器旋钮(可按压)

旋转旋钮选择需要的效果。效果器具备100种预设，包含Echo, Vocal, Plate和多种双效果组合的预设。选定后，轻按旋钮储存

### 33.峰值/静音 LED灯

当输入信号足够强大或数位效果模组静音时，此LED灯会变亮。

### 34.静音开关

此开关用来启动/关闭效果设备

### 35.电源LED灯

打开电源开关，电源LED灯就会亮

### 36.48V幻象电源开关&LED灯

48V幻象电源开关只适用于XLR麦克风输入，如果已经启动幻象电源，就不要再连麦克风，并且相对应的LED灯也会亮。

注意：在使用此开关时，要将所有输出位准调到最小，以免产生彭砰砰的噪音。

### 37.CD/磁带输入

通过此插口来接收录音机或磁带的信号。

当使用 TAPE TO MAIN开关，就可以将答录机信号输送到主混音。当使用前面板上的CD/磁带开关，信号就可以被输送到控制室/耳机输出。如果你使用的是一个单通道设备的话，就需要使用Y型RCA转换器。

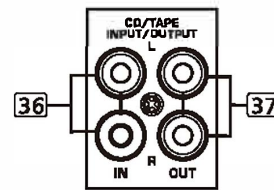

### 38.CD/磁带输出

这些RCA插座会将主输出信号输送到录音带,磁带输出位准是由主混音推子控制.

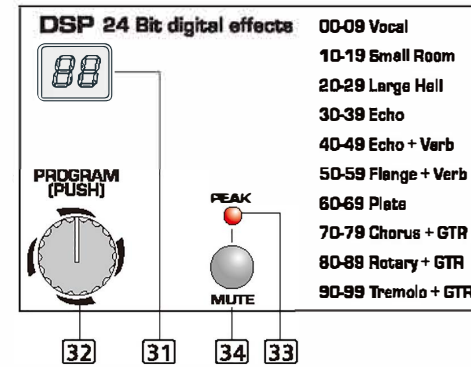

## CONTROL ELEMENTS

### REAR PANEL

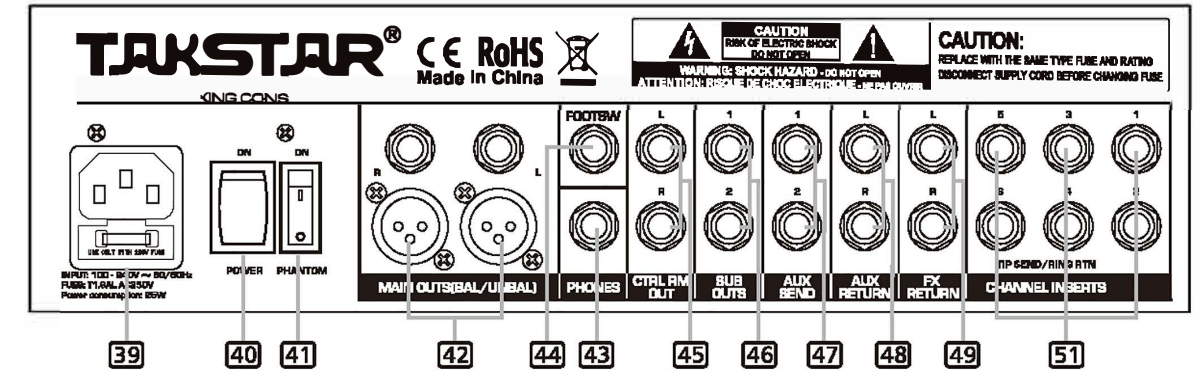

### 39- AC Inlet with Fuse Holder

Use it to connect your mixer to the main AC with the supplied AC cord. Please check the available voltage in your country and voltage required for your mixers before attempting to connect your unit mixer to the main AC.

### 40- POWER ON/OFF Switch

This switch is used to turn the main power ON or OFF. When powered on the power LED on the front panel lights up.

### 41- PHANTOM ON Switch

This switch will apply +48VDC Phantom Power only to the four XLR microphone inputs.

Never connect microphones when the phantom power is on already.

NOTE: Turn down all output levels before operating this switch to avoid the possibility of "pop" in your speakers. Do not use phantom power with tube or ribbon microphones, as this may cause damage.

### 42- XLR MAIN OUTS

These two outputs are supplied with the XLR connectors. Connect these to the inputs of your main power amplifier, powered speaker, or serial effects processor.

### 43- PHONES Jack

This socket will send out the mix signal to a pair of headphones, and the signal is the same as the CTRL RM OUTS outputs. The level controlled by the CTRL ROOM / PHONES knob. You can listen to the Main Mix, the CD / TAPE, or SUB1-2 depending on these CONTROL ROOM SOURCE select switches.

### 44- FOOT Switch

This 1/4" TS jack can be used to connect an external footswitch for engaging the internal FX BYPASS function. If the LED which next to the FX BYPASS switch lights up, it means the bypass function is engaged.

### 45- CONTROL RM OUT

These 1/4" TRS jacks are used to send the control room signal to the studio monitor speakers or a second set of PA. They can also be used to provide another main mix output, or to monitor the CD/TAPE Inputs (when CD/TAPE switch pushed in), or to monitor the ALT3-4.

## CONTROL ELEMENTS

### 32- PRESET SELECTOR

Adjust this knob to select the right effect you wish to perform. There are totally 100 options for you: ECHO, VOCAL, PLATE and versatile two-effect combination. When you are satisfied with the right preset, push this knob to store this preset you want.

### 33- PEAK/MUTE LED

This LED lights up when the input signal is too strong or in case of the digital effect module being muted.

### 34- MUTE SWITCH

This switch is used to activate / deactivate the effect facility.

### 35- POWER LED

This LED lights up when the power switch is turned on.

### 36- PHANTOM 48V Switch and LED

This +48VDC Phantom Power switch only apply to the XLR microphone inputs. Never connect microphones when the phantom power is on already. The LED near to this switch will light up when the phantom power is switched on.

NOTE: Turn down all output levels before operating this switch to avoid the possibility of "pop" in your speakers. Do not use phantom power with tube or ribbon microphones, as this may cause damage.

### 37- CD/TAPE INPUTS

Use the Tape Input if you wish to listen to your mixer from a Taper Recorder or DAT. When the TAPE TO MAIN switch is pushed in, you can assign the signal coming from Taper Recorder to main mix; when the CD/TAPE switch which on the front panel is engaged in the signal can also be assigned to the CONTROL ROOM/PHONES outputs If you connecting a mono device, you will need a "Y-splitter" RCA adapter.

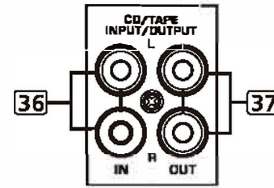

### 38- CD/TAPE OUTPUTS

These RCA sockets will route the main out signal into a tape recorder or DAT. The TAPE OUT level is affected by MAIN MIX faders.

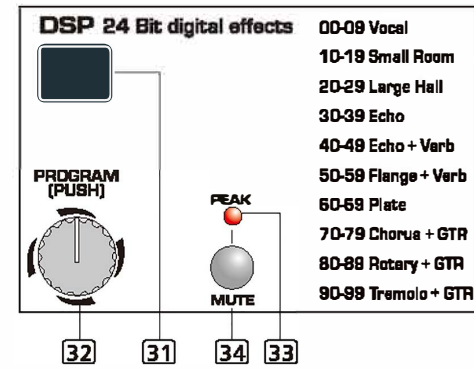

## 控制单元

### 后面板

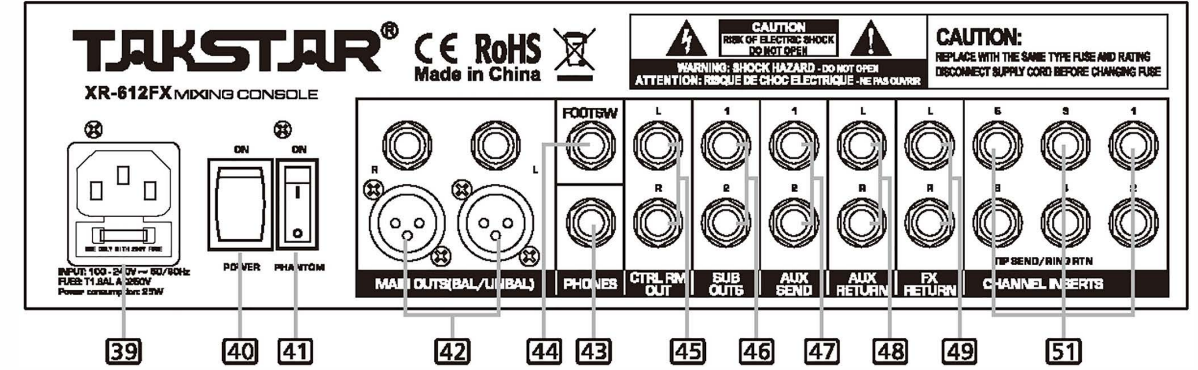

### 39.交流AC座和保险套管

通过交流电插头将mixer与交流电源相连，但是在使用之前请确认好此mixer所允许的电压值。

### 40.电源开关

用来开关电源设备，连接电源时，电源LED灯会亮。

### 41.幻象电源开关

当使用XLR麦克风输入时，就会用到+48V幻象电源开关。  
注意：在使用此开关前，要关掉所有输出，以免产生砰砰的噪音。

### 42.XLR主输出

此输出是与XLR插口配套使用，可与功放，喇叭或效果处理器相连。

### 43.耳机插口

此插口可以将信号输送到与之配套的耳机，其输出信号是与控制室输出一致，由控制室/耳机旋钮所控制。你可以根据控制室声源/音源选择开关选择信号来自自主调音台，CD/磁带，SUB 1-2

### 44.脚踏开关

此插口用来连接外置脚踏开关，如果紧邻FX BYPASS开关的LED灯亮起，标示bypass功能在使用。

### 45.监听输出

此插口用来将控制室信号输送到监听喇叭或PA功放。也可以用来提供主混音输出，或监听CD/磁带输入，或监听ALT3-4输出。

## 控制单元

### 46. -SUB输出

此为非平衡性输出，其信号水准由前面板上的SUB1-2旋钮控制。

### 47. 辅助输出

此插口用来将辅助总线的信号输送到外部设备，例如外部效果设备。也可以通过与功放或喇叭相连后作为监听输出使用。

### 48. 立体辅助回程输入

此插座用来连接内接效果器的回程信号传送至主输出总线，由Master AUX RETURN旋钮控制，如果将单通道信号输送到辅助回程，就可以只使用左边输入。

### 49. 立体效果回程输入

此插座用来连接外接效果器设备，如果你插入的是6.35mm插口，它就会与内部效果处理器断开。

### 50. 6.35mm主输出插口

此插口用来连接外接功放的输入或主动式喇叭的输入。与后板上XLR主输出信号一致。

### 51. 通道插口1-6

此MIC单通道插口，每个插口都位于相应输出通道的均衡器和通道衰减器之间。这些插口可用来独立地将这些通道连接到各种设备，如图形均衡器，压缩器等。

## CONTROL ELEMENTS

### 24- MAIN/SUB1-2 Switch

AUX RETURN is equipped with the MAIN / SUB1-2 switch. Release the switch to send the stereo signal from AUX RETURN to MAIN MIX buses; and engage this switch the stereo signal will be sent to SUB1-2 buses.

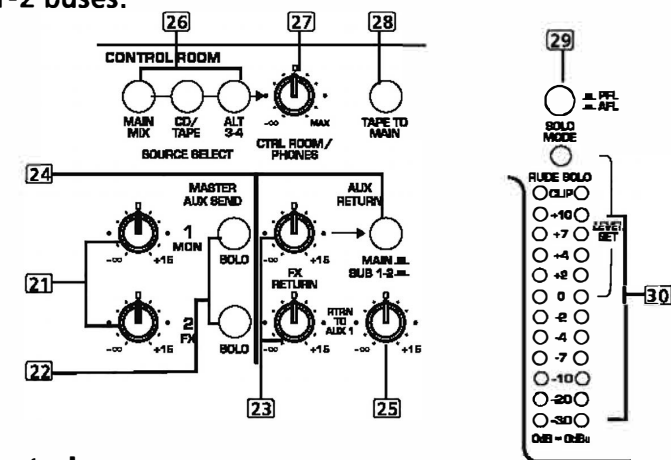

### 25- RTRN TO AUX1 Level Control

This control will route the signal that is present at the FX RETURN jacks to AUX1 output so that the effects can be heard in the monitor mix.

### 26- CONTROL ROOM SOURCE Switches

You can choose to monitor any combination of MAIN MIX, CD / TAPE, and SUB1-2 via these switches. The corresponding stereo signals will be delivered to the CONTROL ROOM / PHONES and LED display.

### 27- CTRL ROOM/PHONES Knob

This control is used to adjust the output level of CTRL ROOM/PHONES.

### 28- TAPE TO MAIN Switch

You can connect a CD or Tape Deck to the CD/TAPE inputs and press this switch to send the CD/TAPE signal to the main mix. Also, you can use the MAIN MIX controls to adjust the volume level.

### 29- SOLO MODE (PFL/AFL) & RUDE SOLO LED

By pushing down this button will made the selected signal of CONTROL ROOM SOURCE replace by the SOLO signal, going into the CONTROL ROOM OUTPUTS, PHONES and the RIGHT LED DISPLAY (LEFT and RIGHT LED DISPLAY when in AFL SOLO MODE). The audible SOLO levels are controlled by the CTRL ROOM/PHONES knob. The button provides two modes: up for PFL (Pre-Fader-Listen) mode, down for AFL (After-Fader-Listen) mode. In either mode, SOLO will not be affected by a channel's MUTE/ ALT switch position.

**NOTE:** Be caution when switching from AFL to PFL mode. If you have the channel fader turned down too much below the unity gain while in AFL mode, switch to PFL mode will cause a sudden and startling increase in volume level.

When the solo mode is engaged, the SOLO LED will light up. (In PFL Solo mode ,the RUDE SOLO LED is green, while in AFL Solo mode, the LED is red.)

## INTERNAL EFFECTS SECTION

### 30- OUTPUT LEVEL LED DISPLAY

These stereo LED meter will indicate the level of the overall output signal.

### 31- DISPLAY

It displays the selected preset.

## CONTROL ELEMENTS

### 15- 1-2 & L-R Switches

Each channel provides two assignment switches: 1-2, and L-R. Pressing the 1-2 will assign the channel signal to SUB1-2, you can depend on the PAN / BAL control to adjust the amount of channel signal sent to the SUB1 versus SUB2, when turns the PAN / BAL to completely left, then the signal can be only controlled by SUB1 and vice-versa. In the same way, pressing the L-R will assign the channel signal to MAIN MIX L-R. This switch must be engaged in to get the channel's signal through to main outs.

### 16- Fader

This control will adjust the overall level of this channel and set the amount of signal sent to the main output.

### 17- SUB 1-2 ASSIGN TO MAIN MIX Switches

Through these switches, you can operate the SUB1-2 faders as a master control for assigning the SUB 1-2 to MAIN MIX. Engage the LEFT switch to send the corresponding sub signal to MAIN MIX L, and the RIGHT switch for MAIN MIX R. When engaging the both switches, the signal will be sent to L/R of MAIN MIX.

### 18- SUB1-2 Master Faders

These faders are used to control the levels of signal that send to the SUB1-2 OUT. The range goes from  $-\infty$  to +10 dB.

### 19- SUB1-2 MUTE SWITCHES

By pushing in the MUTE switch, the corresponding channel can be mute.

### 20- MAIN MIX Faders

These two faders set the level of main mix signals sent to the Main Outputs, Tape Outputs, CONTROL ROOM, PHONES, and LED display. Note: When connecting a speaker to the speaker output jacks on rear panel, please pay more attention to the level setting for avoiding damaging the speaker. Generally, the faders will be positioned between 0 dB (U) & +5 dB.

### 21- MASTER AUX SEND Controls

Both knobs are used to determine the master AUX SEND levels. The adjustable range is from  $-\infty$  to +15 dB. When the external effect unit connected to mixer has no input gain control, you can get a further +15 dB gain available from these AUX SEND outputs.

### 22- MASTER AUX SEND SOLO Switches

From these two switches you can monitor the aux send signals in the CONTROL ROOM and PHONES outputs.

### 23- AUX/FX RETURN Level Controls

These two controls adjust the amount of the AUX / FX Return signal that added to the L / R main mix buses just before the MAIN MIX fader.

If you not plug any signal into FX RETURN inputs, the FX Return signal comes from the internal effects module; If you plug an external effects processor into FX RETURN inputs, the internal effects is disconnected and only the external effects signal is routed through the FX RETURN level control.

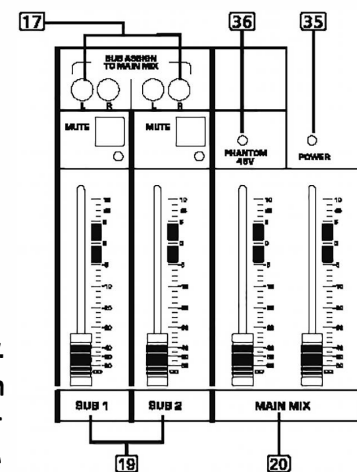
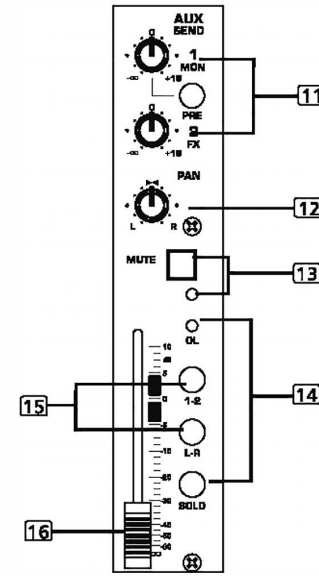

## 控制单元

### USB播放部份-路径模组

USB播放时的存储档必须是FAT16和FAT32，并且只能读取MP3格式的档，总共有7个下阶档。

#### 1. USB插孔

用来与USB卡相连

#### 2. ⏮ 上一曲播放

在暂停阶段，按下此键会进入上一个路径，并保持暂停状态。在播放阶段，按下此键会进入上一个路径并开始播放。

#### 3. ⏭ 下一曲播放

在暂停阶段，按下此键会进入下一个路径，并保持暂停状态。在播放阶段，按下此键会进入下一个路径并开始播放。

#### 4. 📁 录音

按下此键，播放器会在如下四种模式下转变：

REP ALL代表会录下所有路径并且在萤幕上显示 📁

REP1代表会录下一种路劲，萤幕上显示 📁

按顺序播放代表会按照指定的路径按顺序依次播放，萤幕上显示是空格随机播放

代表会不按照制定路劲随机播放，萤幕上显示A

#### 5. ⏸ 播放/暂停

在播放阶段，按下此键会暂停播放。在暂停阶段，按下此键会开始播放

#### 6. ■ 停止

在播放阶段，按下此键会暂停播放，储存卡里面所有歌曲会出现在萤幕上。

在暂停阶段，按下暂停/播放/下一曲按键，会进入第一首歌曲播放，但是播放器处于暂停状态，按下 ⏭ 开始播放歌曲

#### 7. 开/关机

当播放器关机时，按此键2~3秒重新开启播放器电源。重复如上操作，也可以关闭播放器电源

#### 8. 播放显示幕

所有MP3播放资讯都会通过此显示幕展示

备注：介面显示资讯

播放器与USB储存卡没有相连时，介面如下：

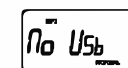

播放器寻找USB路径时，介面如下：

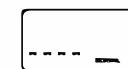

播放器处于暂停状态，介面如下：



播放器处于使用状态时，介面如下：

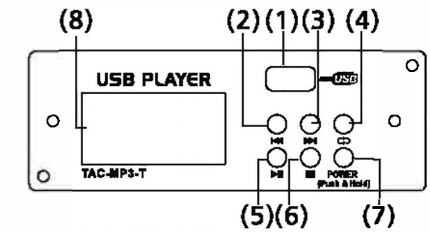

## 安装指示

### 安装

- 1.将喇叭置于空旷的区域，如果可以固定于三脚架上，接收与传播会更好
- 2.在安装喇叭时请参考专业的意见和建议，安装时要确保不会掉落或伤害他人。  
安装时也请注意保护好木箱及零部件。
- 3.安装时请使用高品质专业电线。
- 4.功放与喇叭的功率及阻抗要匹配。选用合适的功率有助于音质的提高及使用寿命的加长。此外，选用时，木箱功率也要符合要求

## CONTROL ELEMENTS

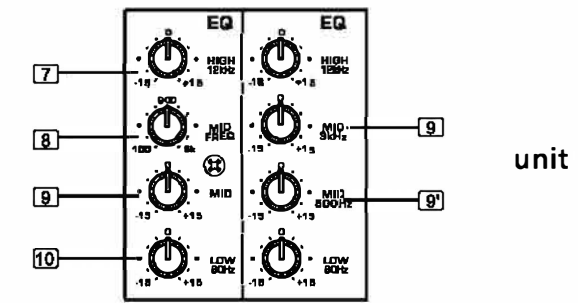

### 8- MID FREQ

It can change the center frequency for the MID EQ filter. From this knob you can more accurately select the band of frequency that you want to boost or cut. The ranges goes from 100 Hz to 8 kHz.

### 9- MID EQ

This control provides 15 dB boost or cut at 2.5 kHz on the unit has one sweepable MID EQ controls on the mono channels and two discrete MID EQ on the stereo channels with center frequencies at 3 kHz and 500 Hz(9'), the midrange frequencies include the upper male and lower female vocal ranges, and the fundamentals and harmonics for many instruments.

### 10- LOW EQ

This is the bass control. It is used to boost male voice, kick-drum or bass guitar. Your system will sound much bigger than what it is. The gain range goes from -15 dB to +15 dB with a center frequency of 80 Hz.

### 11- AUX Send Controls

These two controls are used to adjust the level of signal sent to AUX bus 1&2, and this adjustment doesn't effect the main mix output signal at all.

AUX SEND1 ( MON ) can be configured as PRE / POST fader via the PRE switch. Up for POST fader, the signal is sent out after the channel fader and will be affected by the channel fader. Down for PRE fader, the signal is sent out before the channel fader and will not be affected by the channel fader. AUX 2 (FX) is configured as POST fader.

### 12- PAN/BAL

Abbreviation of PANORAMA control for mono channels, for the stereo channels, always says, BALANCE control. You can adjust the stereo image of the signal via this control. For mono MIC / LINE channels, keep PAN control in centre position and your signal will be positioned in the middle of stage that is to say the mono signal appears equally in both sides. Turn this control fully counterclockwise and the signal will be present only on the left speaker and vice-versa. For stereo channels, by rotating the BAL control, you can attenuate the signal of left or right. It means if turn the control to left, the right channel will be attenuated; if turned to right, the left channel will be attenuated.

### 13- MUTE SWITCH

Each channel is equipped with the MUTE switch. Pressing this switch is equal to turning the fader down, which can mute the corresponding channel output except for SOLO (in PFL mode), the MUTE LED will illuminate.

### 14- SOLO SWITCH & OL LED

When pressing this switch, the OL LED will illuminate and the SOLO signal will replace other signals and reach to the CONTROL ROOM/PHONES. Usually use the SOLO function to preview each channel before they are get into the mix. You can solo more than one channel at a time. And the soloed channels are sent to the CONTROL ROOM, PHONES, and LED display. Engaging the SOLO switch, all CONTROL ROOM SOURCE selections MAIN MIX, CD / TAPE, SUB1-2 will be muted.

## CONTROL ELEMENTS

### FRONT PANEL

#### 1- Mono MIC Input

The TAKSTAR XR-612FX is equipped with 6 low-noise mic preamplifiers with optional phantom power providing up to 50 dB of amplification. You can connect almost any type of microphone. Dynamic microphones don't need phantom power. Use phantom power only with condenser microphones but make sure that the phantom power switch is disengaged before connecting the microphone. Phantom power will not damage your dynamic microphones but it may damage tube or ribbon microphones so make sure to read the microphone instructions manual before engaging phantom power switch. There are also equipped with 1 / 4" TRS balanced and TS unbalanced LINE IN plug, you can connect with line-level instruments, such as synthesizers, key-boards, drum machines or effect devices.

NOTE: Never try to connect a line-level signal to the XLR MIC input when the phantom power is engaged, doing this you may seriously damage your equipment.

#### 2- STEREO LINE INPUTS

They are organized in stereo pair and provided with 1/4" TRS jacks. It is used to connect the stereo device, plug both the left input and the right input. Using the left input if connect a mono input signal to the STEREO INPUT, the signal will appear on both sides.

#### 3- GAIN CONTROL

This GAIN control is used to control the input sensitivity of the MIC and LINE inputs. The adjustable range goes from 0 dB to 50 dB.

#### 4- 75 Hz Low-Cut Switch

By pressing this button you will activate a 75 Hz low frequency filter that cuts the bass frequency below 75 Hz. You can use this switch to reduce the hum noise caused by the mains power supply, or the stage rumble while using a microphone.

#### 5- +4/-10 Switch

+4/-10 switches are used to select the input sensitivity of the line inputs on the stereo channels. +4 dBu is suitable for professional audio devices and -10 dBv is suitable for general devices. If not sure to use which setting, try +4 dBu first, then change it to -10 dBv if the volume is too small to be satisfied.

#### 6- LINE/MP3 Switch

By pressing this button, it will switch to the MP3 mode, then the MP3 signal can be sent to this channel or the Main Mix channel; by releasing this button, LINE IN inputs signal will send to the line input channels.

### EQUALIZATION

The unit is equipped with 3-band EQ with sweepable MID on all mono channels and 4-band EQ on stereo channels. All bands provide up to 15 dB boost or cut.

#### 7- HIGH

This is the treble control. You can use it to get rid of high frequency of the human voice. The gain range goes from -15 dB to +15 dB with a centre frequency of 12 kHz.

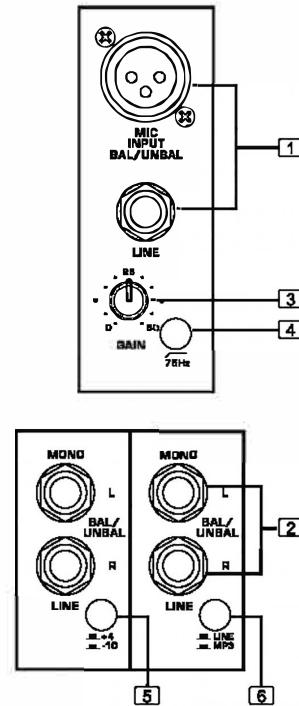

## 安装指示

6.35mm TRS插口或XLR插口均可以在平衡和非平衡模式下相连，具体依据实际应用状况而定。以下链接方式供参考：

### -6.35mm耳机插口

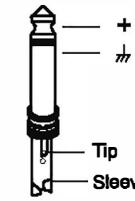

TS非平衡型

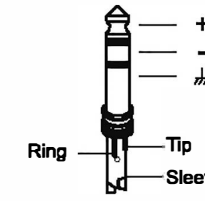

TRS平衡型

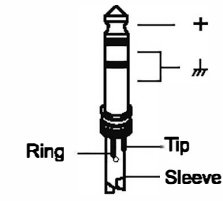

TRS非平衡型

### -XLR接口

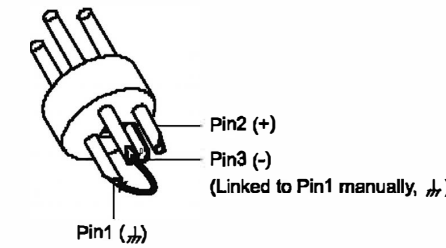

XLR非平衡型

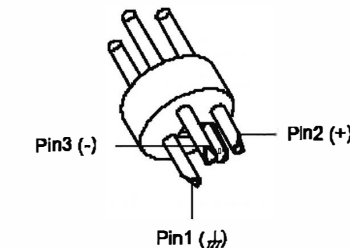

XLR平衡型

### 在线连接

对于既提供6.35mm插口又提供XLR插口的设备是很容易与专业的音频设备相连的，以下连接供参考：

#### -平衡型

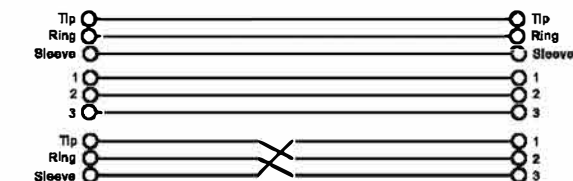
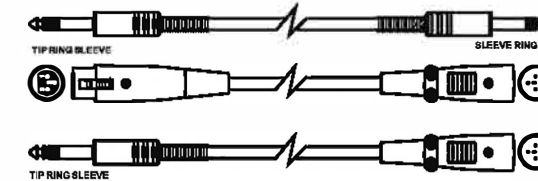

#### -非平衡型

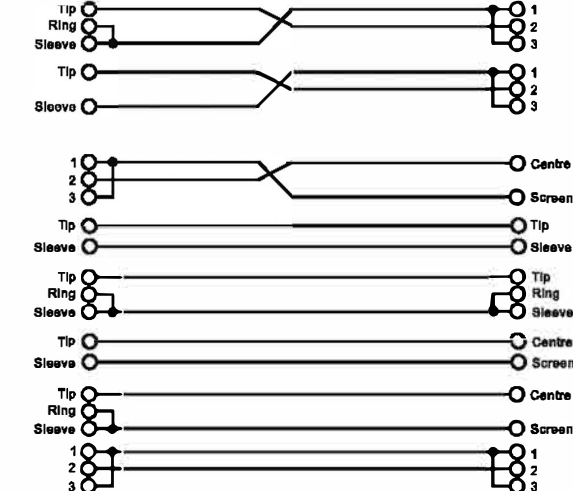
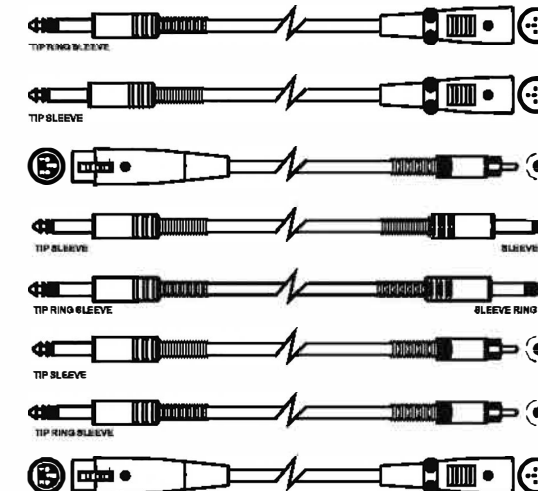





## INTRODUCTION

Thank you for purchasing the XR-612FX mixing console.

The unit mixing console is packed with some features that can not be found in other consoles of its size: 6 these are provided with ultra low noise microphone preamplifiers and phantom power at +48V) and 2 stereo input channels and each of them is provided with warm, natural EQ; 2-Track inputs assign-able to Main mix, Phones / Control Room outputs etc. Besides, the 24-bit effect processor with 100 effects.

Please read this manual carefully so you can take advantages of all the features of the unit

Thank you again for making the right choice in purchasing the TAKSTAR MUSIC GEAR.

The unit can be used in following electromagnetic environment: residential, commercial and light industrial, urban outdoors. They are the apparatus not intended for rack mounting.

For unit the peak inrush current is 4.16A

## FEATURES

- 6 mono inputs with gold plated XLR and Balanced TRS jack
- stereo inputs with Balanced TRS jack
- GAIN control and +48V phantom power for mono inputs
- 3-band EQ with sweepable MID (plus 75Hz low cut filter) on all mono channels and 4-band EQ on stereo channels
- 2 AUX sends: AUX1 with PRE / POST-fader switch for monitoring, AUX2 POST-fader for effect sends can be changed in PRE-fader for monitoring
- Each input channel features MUTE, SOLO switches and OL LED
- SUB1-2 and L-R assign switches, on each channel
- 2-Track IN/OUT with discrete switches for routing to Control Room and to Main Mix
- Two different ways of SOLO PFL/AFL for a better control over signal path
- Balanced XLR & TRS jack output
- 24-bits internal DSP with 100 effects, DSP MUTE & Peak LED

## 预设清单

No.	Preset	Description	Parameter
00~09	Vocal	Simulate a small space with slight	Rev.delay time: 0.8~0.9s Pre-delay: 10~45ms
10~19	Small Room	Simulate a bright studio room	Decay time: 0.7~2.1s Pre-delay: 20~45ms
20~29	Large Hall	Simulate a large acoustic space	Decay time: 3.6~5.4s Pre-delay: 23~55ms
30~39	Echo	Echo/Delay effect	Delay time: 145~205ms
40~49	Echo+Verb	Echo & Reverb combination	Delay time: 208~650ms Decay time: 1.7~2.7s
50~59	Flanger+Verb	Flanger effect & Reverb combination	Decay time: 1.5~2.9ms Rate: 0.8Hz~2.52Hz
60~69	Plate	Simulate classic bright vocal plate	Decay time: 0.9s~3.6s
70~79	Chorus+GTR	Guitar Effect: Chorus	Rate:0.92Hz~1.72Hz
80~89	Rotary+GTR	Guitar Effect: Rotary	Modulation depth: 20%~80%
90~99	Tremolo+GTR	Guitar Effect: Tremolo	Rate : 0.6Hz~5Hz

## 技术规格

型号	XR-612FX	
输入通道	麦克风输入	平衡型XLR插口
	频响	20Hz to 50KHz± 3dB
	失真度	<0.005% to +4dBu, 1KHz
	增益范围	0dBa50dB MIC
	信噪比	<-100dB
	幻象电源	+48V 幻像电源开关
	线性输入	平衡型1/4"TRS插口
	频响	20Hz to 50KHz ±3dB
	失真度	<0.005% to +4dBu, 1KHz
	灵敏度	+15dBu ±3dB
阻抗	麦克风输入	1.4K Ohm
	其它输入	10K Ohm
	磁带输出	1k Ohm
	其它输出	120 Ohm
EQ	单通道	
	高EQ	±15dB @ 12Khz
	中EQ	±15dB 频率范围 100Hz to 8KHz
	低EQ	±15dB@ 80Khz
	立体通道	
	高EQ	±15dB @ 12Khz
	中高EQ	±15dB @ 3KHz
	中低EQ	±15dB @ 500hz
	低EQ	±15dB @ 80Khz
	DSP部份	电压转换器
	DSP分辨率	24 Bit
	效果类型	Vocal, Small Room, LargeHall, Echo, Echo+Verb, Flanger+Verb, Plate, Chorus GTR, Rotary GTR, Tremolo GTR
	预设	100
	管控	100个预设选择 (10 Presets, 10 Variations) 带指示灯的静音开关
主混音部份	总线噪音	推子0dB, 静音-82dB, 所有输入通道, 整体增益--70dB
	最大输出	±22dBu 非平衡型, 1/4Jacks
	辅助输送的最大输出	+22dBu
	辅助输送的增益范围	-∞ to +15dB
USB输入	内置USB全速 (12Mbps)	
	支持USB存储	
FAT分解	支持FAT16&FAT32/支持VFAT (较长文件名)	
MP3解码	支持取样率为8kHz, 16kHz, 32kHz, 11.025kHz, 22.05kHz, 44.1kHz, 12kHz, 24kHz, 48kHz,	
	支持8~320字节率, 支持可变的字节率, 但是不支持随意格式的解码	
电气规格	频响	20Hz-20KHz
	新噪比	>90dB
	1kHz失真度	<0.04%
电源	主电压	100-240V~50/60Hz
	保险丝	1.6AL AC250V

## Important Safety Instructions



This symbol, wherever used, alerts you to the presence of un-insulated and dangerous voltages within the product enclosure. These are voltages that may be sufficient to constitute the risk of electric shock or death.



This symbol, wherever used, alerts you to important operating and maintenance instructions.

Please read.



Protective Ground Terminal



AC mains (Alternating Current)



AC mains (Alternating Current)



ON: Denotes the product is turned on.

OFF: Denotes the product is turned off.

### WARNING

Describes precautions that should be observed to prevent the possibility of death or injury to the user.



### CAUTION

Describes precautions that should be observed to prevent damage to the product. Disposing of this product should not be placed in municipal waste but rather in a separate collection.

### WARNING

#### Power Supply

Ensure that them a inssource voltage (AC outlet) matches the voltage rating of the product. Failure to do so could result in damage to the product and possibly the user. Unplug the product before electrical storms occur and when unused for long periods of time to reduce the risk of electric shock or fire.

#### External Connection

Always use proper ready-made insulated mains cabling (power cord). Failure to do so could result in shock/death or fire. If in doubt, seek advice from a registered electrician.

#### Do Not Remove Any Covers

Within the product are areas where high voltages may present. To reduce the risk of electric shock do not remove any covers unless the AC mains power cord is removed. Covers should be removed by qualified service personnel only.

No user serviceable parts inside.

#### Fuse

To prevent fire and damage to the product, use only the recommended fuse type as indicated in this manual. Do not short-circuit the fuse holder. Before replacing the fuse, make sure that the product is OFF and disconnected from the AC outlet.

### Protective Ground

Before turning the unit ON, make sure that it is connected to Ground. This is to prevent the risk of electric shock.

Never cut internal or external Ground wires. Like wise, never remove Ground wiring from the Protective Ground Terminal.

### Operating Conditions

Always install in accordance with the manufacturer's instructions.

To avoid the risk of electric shock and damage, do not subject this product to any liquid/rain or moisture.

Do not use this product when in close proximity to water.

Do not install this product near any direct heat source. Do not block areas of ventilation. Failure to do so could result in fire.

Keep product away from naked flames.

### IMPORTANT SAFETY INSTRUCTIONS

Read these instructions

Follow all instructions

Keep these instructions. Do not discard.

Heed all warnings.

Only use attachments / accessories specified by the manufacturer.

### Power Cord and Plug

Do not tamper with the power cord or plug. These are designed for your safety.

Do not remove Ground connections!

If the plug does not fit your AC out let seek advice from a qualified electrician.

Protect the power cord and plug from any physical stress to avoid risk of electric shock.

Do not place heavy objects on the power cord. This could cause electric shock or fire.

### Cleaning

When required, either blow off dust from the product or use a dry cloth.

Do not use any solvents such as Benzol or Alcohol. For safety, keep product clean and free from dust.

### Servicing

Refer all servicing to qualified service personnel only. Do not perform any servicing other than those instructions contained within the User's Manual.

### PORTABLE CART WARNING



Carts and stands - The component should be used only with a cart or stand that is recommended by the manufacturer.

A component and cart combination should be moved with care. Quick stops, excessive force, and uneven surfaces may cause the component and cart combination to overturn.