

TAKSTAR® 得胜

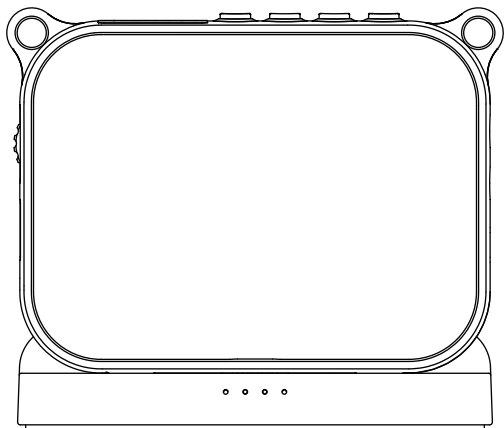

E30 **扩音器**
Voice Amplifier

使用手册 | User Manual

E30 扩音器

■ 前言

尊敬的用户：

感谢您选购得胜E30扩音器，为了您能够更好地了解使用本产品，建议您在使用前仔细阅读本说明书。

若存在有疑问或者您有宝贵的建议，可通过拨打得胜官方服务热线400 6828 333或微信扫描二维码关注得胜官方公众号与我们联系。



■ 产品特性

- 全新外观设计，磁吸式可拆卸网罩搭配精致的充电底座，造型新颖，外观时尚；
- 新款可拆卸头戴麦克风，支持头戴、领夹和手持等场景使用；
- 数字扩音技术，12W大功率音频输出；
- 选用高效强磁钕铁硼喇叭，重量更轻，音质更好，声音更大；
- 采用LOW-THD自适应技术，在大功率输出时也不会产生明显的声音失真；
- 具有无线播放功能，可连接手机、电脑、PAD等设备播放音乐；
- 具有音乐播放功能，支持U盘、AUX音频信号输入功能，可充当小音箱使用；
- 配备数码显示屏设计，方便实时了解扩音器工作状态；
- 内置大容量耐久型锂离子电池，可循环充电使用，节能环保。

■ 适用范围

适用于教学、导游、培训、促销等场合扩音

E30 扩音器

■ 标准配置

- E30扩音器 1台
- 有线可拆卸麦克风 1个
- 充电线 1条
- 充电座(选配) 1台
- 腰带 1条
- 说明书 1份

■ 技术参数

主机参数(扩音器)

- 频率响应: 80Hz-18kHz
- 峰值功率: 12W
- 扬声器阻抗: 4Ω
- 无线连接版本: 5.3
- 工作电压: DC 3.5-4.2V
- 电池规格: 18650单节3.7V/2500mAh
- 产品规格: 120*90*35mm
- 充电方式: Type-C
- 充电时间: 约2小时
- 充电规格: 5V=1.5A
- 使用时间: 约15小时
- 单机重量: 约180g

音头参数

- 拾音器: 背极式驻极体
- 指向性: 单指向
- 频率响应: 100Hz-12.5kHz
- 灵敏度: -42~-48dB
(0dB=1V/Pa, at 1KHz)

注: 以上数据由得胜实验室测试得到,并拥有最终解释权!

■ 功能示意

扩音器

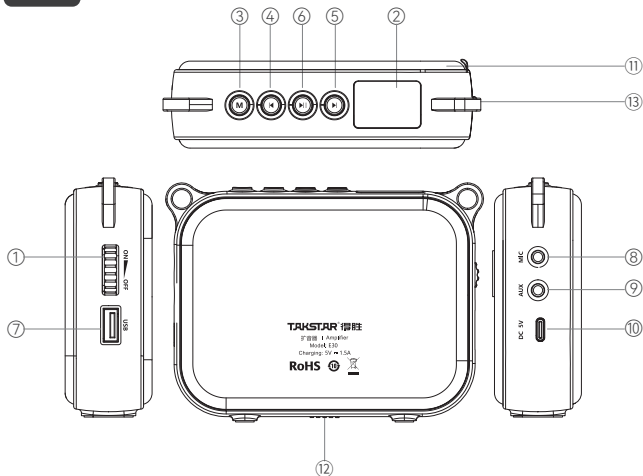

- ① 电源开关和音量调节旋钮：向“ON”方向拨动旋钮，听到“哒”一声，表示扩音器已开机并进入人声扩音状态，此时数码显示屏②亮起；继续向“ON”方向拨动声音逐渐增大，反之向“OFF”方向拨动则声音逐渐减小，直至听到“哒”一声关机。
- ② LED数码显示屏：显示当前的工作模式、电池电量等信息。开机同步显示电池电量百分比；15分钟后无任何操作时，显示屏出现“— — — —”符号，表示扩音器进入待机状态，按任意键即可唤醒。

E30 扩音器

- ③ “M”模式切换键: 开机状态下, 短按该按键可切换工作模式, 并伴随相应的语音提示。(当插入U盘和麦克风状态下, 长按此按键进入录音模式, 录制完成后长按此键可退出并保存录音, 退出录音模式后, 自动循环播放刚录制的內容)。
- ④ 上一曲键: 在USB、无线播放状态下, 短按切换为上一曲。
- ⑤ 下一曲键: 在USB、无线播放状态下, 短按切换为下一曲。
- ⑥ 播放/暂停键: 正常播放状态下, 循环点按此按键控制音乐的播放及暂停; 在无线播放模式下, 长按此键可断开无线连接。
- ⑦ USB接口: 可将储存有音乐文件的U盘插入此接口进行播放。
- ⑧ MIC输入接口: 将有线麦克风插头插入此接口, 进入有线人声扩音状态。操作时, 请不要将麦克风的拾音面朝向扩音器的扬声器, 以免产生啸叫。
- ⑨ AUX输入接口: 通过 $\varnothing 3.5\text{mm}$ 音频连接线与手机、电脑、平板等播放设备连接, 可将扩音器作为有源音箱使用。
- ⑩ 充电接口: 连接Type-C充电线为扩音器充电。
- ⑪ 磁吸式可拆卸网罩: 从喇叭网罩下方中间位置槽位将网罩拆下, 然后更换其他喇叭网罩。
- ⑫ 磁吸充电触点: 通过接触传导方式将充电底座与扩音器底座的磁吸充电触点对准贴合, 实现无线充电。
- ⑬ 挂扣: 用于安装肩带, 可将扩音器斜挂于肩上使用。

充电底座

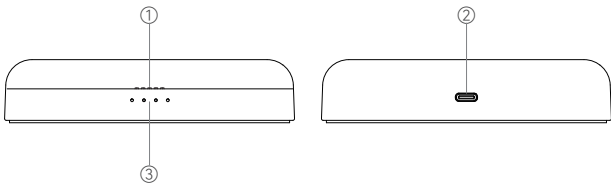

- ① 磁吸充电触点: 通过接触传导方式将充电底座与扩音器底座的磁吸充电触点
对准贴合, 实现无线充电。
- ② Type-C接口: 将扩音器放置在充电底座上, 连接Type-C充电线为扩音器充
电。
- ③ 充电指示灯: 共4个指示灯, 每个代表25%电量。充电时, 指示灯白灯呈逐格
流水点亮, 充满后白灯满格常亮显示。

■ 使用说明

一、使用方法

1. 通过有线可拆卸麦克风的可切换磁吸设计, 选择头戴或领夹方式佩戴, 并调
整好麦克风的拾音角度;
2. 然后将有线麦克风的 $\varnothing 3.5\text{mm}$ 插头插入MIC输入接口内;
3. 打开扩音器电源开关, 数码显示屏亮起, 调整音量旋钮至合适音量使用。

提示: 初次使用时, 建议先充满电; 如长时间不使用, 需每半年给扩音器充一次
电, 避免电池过放, 对电池性能产生影响。

二、无线播放配对

首次使用本机时，需要与手机或无线播放设备配对连接，步骤如下：

1. 先打开扩音器电源开关，点按“M”键切换成无线播放模式，扩音器自动进入搜索配对状态。
2. 进入手机的“设置”菜单，开启手机的无线播放功能，搜索“TAKSTAR E30”进行连接，出现语音提示时，表示无线播放已连接成功。
3. 下次开机后选择到无线播放模式下，将自动回连最后一次使用的播放设备。
4. 在无线播放连接成功的情况下，长按“播放/暂停”按键可断开播放。

■ 安全警示

为避免电击、高温、着火、辐射、爆炸、机械危险以及使用不当等可能造成的人身伤害或财产损失，使用本产品前，请仔细阅读并遵守以下事项：

1. 使用产品时请确认所连设备与本产品是否匹配以及合理调整音量大小，不要在超过产品功率及大音量下长时间使用，以免造成产品异常；
2. 使用中若发现有异常（如冒烟、异味等），请立即关闭电源开关并拔掉电源插头，然后将产品送售后服务网点检修；
3. 若产品需要使用可拆装电池时，严禁使用外壳绝缘材料破损的电池，请不要为非充电电池充电；
4. 本产品及配件都应放置在室内干燥通风处，请勿长期存放在潮湿、灰尘多的环境，使用中避免靠近火源、雨淋、进水、过度碰撞、抛掷、振动本机及覆盖通风孔，以免损坏其功能；
5. 若产品需要固定于墙壁或天花板时，请确保固定到位，防止因固定强度不足导致产品发生跌落危险；
6. 使用该产品时需遵守相关安全规定，法律法规明确禁止使用场合请勿使用本产品，以免导致意外事故；

E30 扩音器

7. 请不要自行拆机改装或维修, 以防止出现人身伤害, 如有问题或服务需求请联系当地售后服务网点跟进处理。

■ 环保说明

产品中有害有毒物质或元素的名称及含量标识表

部件名称	有害有毒物质或元素					
	铅 (Pb)	汞 (Hg)	镉 (Cd)	六价铬 (Cr(VI))	多溴联苯 (PBB)	多溴二苯醚 (PBDE)
塑料部件	○	○	○	○	○	○
金属部件	×	○	○	○	○	○
电路板组件	×	○	○	○	○	○
线缆	×	○	○	○	○	○

本表格依据SJ/T 11364的规定编制

○: 表示该有害物质在该部件所有均质材料中的含量均在GB/T 26572规定的限量要求以下。

×: 表示该有害物质至少在该部件的某一均质材料中的含量超出GB/T 26572规定的限量要求。

此标志为产品的环保使用期限标志,

且此环保使用期限只适用于产品正常工作的温度和湿度等条件。



■ 关于图标含义解释



此符号表示, 根据WEEE指令(2012/19/EU)和国家法律, 由于这种类型的废弃物会有潜在的有害物质, 可能对环境 and 人类健康产生负面影响, 所以本产品不应与您的家庭垃圾一起处置, 应将本产品交由授权的电气和电子设备(WEEE)回收站回收。同时, 您在正确处理本产品的同时将有助于自然资源的有效利用。如需了解更多有关您可以在何处放置废物回收设备的信息, 请联系您当地的城市办事处、废物管理局或家庭废物处理服务部门。

■ 关于本说明书

本说明书中内容符合截止印刷之日的技术规格。由于得胜公司会不断改进产品，本说明书可能不符合您的特定产品的技术规格。要获取最新版说明书，请访问得胜官网，然后下载说明书文件。技术规格、设备或另售的附件在各个地区可能有所不同，如有问题请与当地得胜销售网点确认。如需更多支持和深层产品信息，请浏览得胜官方网站：<https://www.takstar.com>

版权所有 ©2023 得胜。得胜、TAKSTAR及其各自标志是广东得胜电子有限公司在中国和/或其他国家/地区的注册商标或商标。所有其它商标均是其各自所有者的财产。

■ Preface

Dear Customer,

Thank you for purchasing Takstar E30 Voice Amplifier. To better understand and use the product, please read this manual thoroughly. If you have any questions or suggestions, please contact our local sales outlet.

■ Features

- New stylish design with detachable magnetic cover and sleek charging dock.
- Mic convertible to headset, lapel or handheld use for any scenario.
- 12W digital amplification for penetrating volume.
- High-efficiency rare earth driver for lower weight & superior sound.
- Adaptive LOW-THD technology prevents distortion even at high power.
- Connect phones, tablets and more to broadcast audio wirelessly.
- Play music from USB/AUX inputs like a portable speaker.
- Monitor amplifier status easily via digital display.
- Built-in durable, rechargeable lithium-ion battery.

■ Applications

Teaching, tour guiding, training, and promotions.

E30 Voice Amplifier

■ Package Contents

1 × E30 Amplifier	1 × Wired Convertible Mic	1 × Charging Cable
1 × Charging Dock (optional)	1 × Strap	1 × User Manual

■ Specifications

Voice Amplifier

- Frequency Response: 80Hz-18kHz
- Peak Power: 12W
- Speaker Impedance: 4Ω
- Wireless Version: 5.3
- Operating Voltage: DC 3.5-4.2V
- Battery Specs: Single 18650, 3.7V/2500mAh
- Product Size: 120×90×35mm
- Charging Method: Type-C
- Charging Time: Approx. 2 hours
- Charging Specs: 5V=1.5A
- Battery Life: Approx. 15 hours
- Product Weight: Approx. 180g

Microphone

- Capsule: Back Electret Condenser
- Polar Pattern: Uni-directional
- Frequency Response: 100Hz-12.5kHz
- Sensitivity: -42~-48dB (0dB=1V/Pa, at 1kHz)

Note: The above data are measured by Takstar laboratory which has the final interpretation right!

■ Function Descriptions

Voice Amplifier

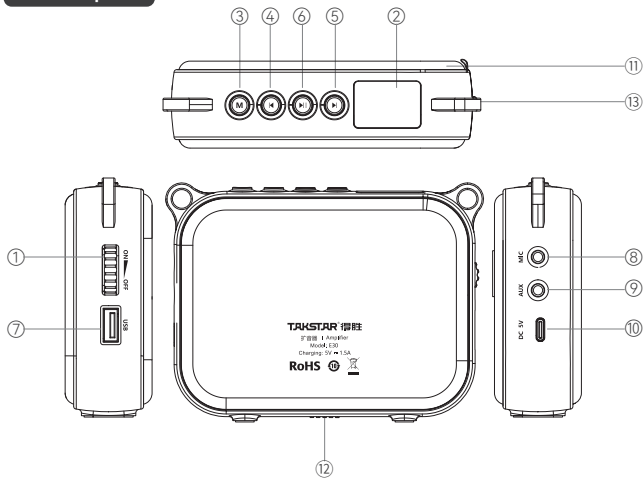

1. Power Switch and Volume Knob: Rotate towards ON until you hear a click to power on the device and start voice amplification. The digital display screen ② will light up. Continue rotating towards ON to gradually increase the volume. Rotating towards OFF will gradually decrease the volume and eventually power off the device when you hear a click.
2. LED Digital Display: Shows the current operating mode, battery level, and other info. Battery percentage is shown upon power-up., the

E30 Voice Amplifier

Battery percentage is shown upon power-up., the display screen will show a — — — — symbol, indicating that the voice amplifier has entered standby mode. Press any key to wake it up.

3. [M] Mode Switch Button: When powered on, short press to switch between different operating modes, accompanied by corresponding voice prompts. (When a USB flash drive and mic are connected, long press to enter recording mode. Press again after recording to exit and save the recording. Upon exiting, the recorded content will be played automatically in a loop.)
4. Previous Track Key: In USB or wireless playback mode, short press to switch to the previous track.
5. Next Track Key: In USB or wireless playback mode, short press to switch to the next track.
6. Play/Pause Key: In normal playback modes, press to play/pause music. In wireless playback mode, long press to disconnect the wireless connection.
7. USB Port: Insert a USB flash drive to play the music files stored in it.
8. MIC Input Port: Connect a wired mic to this port to start wired voice amplification. Please ensure that the mic's pickup side is not facing the amplifier's speaker to avoid feedback.
9. AUX Input Port: Connect the amplifier to a mobile phone, computer, tablet, or other playback devices using a Ø3.5mm audio cable. This allows you to use the amplifier as an active speaker.
10. Charging Port: Connect the amplifier to a Type-C charging cable for charging.

E30 Voice Amplifier

11. Magnetic Detachable Cover: Utilize the slot located at the bottom middle of the cover to pry it open, detach and replace it with another speaker cover.
12. Magnetic Charging Contacts: Align the magnetic charging contacts on the charging dock with those on the base of the amplifier to achieve cordless charging.
13. Strap Hook: Attach a strap for shoulder wearing.

Charging Dock

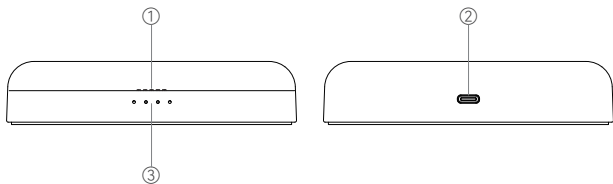

1. Magnetic Charging Contacts: Align the magnetic charging contacts on the charging dock with those on the base of the amplifier to achieve cordless charging.
2. Type-C Port: Place the amplifier on the charging dock and connect the Type-C charging cable to charge the amplifier.
3. Charging Indicators: There are a total of 4 indicator lights, each representing 25% battery capacity. The indicator lights will illuminate white sequentially while charging, and all stay lit when fully charged.

■ Operating Instructions

I. How to Use

1. Choose between the head-worn or collar clip style using the detachable and switchable magnetic design, and properly adjust the mic's pickup angle.
2. Insert the Ø3.5mm plug of the wired mic into amplifier mic input port.
3. Power on the amplifier. The digital display screen will light up. Adjust the volume knob to a desired volume level.

Tips: It's recommended to fully charge the device upon first use, and if not used for long periods, charge it for once every six months to avoid battery over-discharge which could affect battery performance.

II. Wireless Pairing

Upon first use, you need to connect this device to your phone or wireless device, following below steps:

1. Power on the amplifier. Press [M] key to switch to wireless playback mode. The amplifier will automatically enter pairing mode.
2. On your phone, go to the Settings menu and enable wireless function. Search for TAKSTAR E30 and connect to it. When connected successfully, there will be a voice prompt.
3. The next time you power on the amplifier and enter wireless playback mode, it will automatically reconnect to the previously paired device.
4. When a wireless connection is established, long press [Play/Pause] button to disconnect the device.

■ Safety Instructions

To avoid electric shock, overheat, fire, radiation, explosion, mechanical risk and injury or property loss due to improper use, please read and observe the following items before use:

1. Please check if the power of the connected equipment matches with that of this product before operation. Adjust the volume to proper level during operation. Do not operate at over-power or high-volume level for extended time to avoid product malfunction.
2. If there is any abnormality during use (e.g., smoke, strange odor), please kill the power switch and unplug from power source, then send the product to the local after-sales service for repair.
3. When using replaceable batteries, do not use batteries with damaged insulation on the casing. Do not attempt to charge non-rechargeable batteries.
4. Keep this product and its accessories in a dry and ventilated area. Do not store in a humid or dusty area for extended time. Keep away from fire, rain, liquid intrusion, bumping, throwing, vibrating, or from blocking any ventilation openings, to prevent malfunction.
5. The product must, when installed on walls or ceilings, be fixed firmly in place at adequate strength to prevent from falling.
6. Please abide by safety rules during operation. Do not use the product in places prohibited by laws or regulations to avoid accident.
7. Do not disassemble or repair the product by yourself to avoid injury. If you have any questions or require any services, please contact our local after-sales service.

■ Label Meanings



This symbol indicates that this product should not be disposed of with your household waste, according to the WEEE directive (2012/19/EU) and your national law. This product should be handed over to an authorized collection site for recycling waste electrical and electronic equipment (WEEE). Improper handling of this type of waste could have a possible negative impact on the environment and human health due to potentially hazardous substances that are generally associated with WEEE. At the same time, your cooperation in the correct disposal of this product will contribute to the effective usage of natural resources. For more information about where you can drop off your waste equipment for recycling, please contact your local city office, waste authority, or your household waste disposal service.

■ About This Manual

This manual contains up-to-date technical specifications as of printing. However, specifications contained herein may not conform to your particular product since Takstar is constantly improving its products. Also, specifications, devices or accessories available may vary from region to region. If you have any questions, please contact our local sales outlet. For the latest version/more information, please visit our website: <https://www.takstar.com/>

Copyright ©2023 TAKSTAR. TAKSTAR, 得胜 and their respective logos are registered trademarks or trademarks of Guangdong Takstar Electronic Co., Ltd. in the PRC, and/or other countries. All other trademarks are the property of their respective owners.

注意事项:

1. 本单为保修凭证, 请用户妥善保管, 如有遗失, 恕不保修或退换。
2. 保修期限制: 购买之日起十二个月内。
3. 除了不可抗力事件损坏外, 由本公司负责, 免费维修。
4. 如属保管不善或使用不当造成的损坏, 维修点将酌情收费。
5. 擅自拆卸维修者, 不予保修。
6. 以上保修条款仅限于中国市场适用 (不含港澳台地区)。

产品服务保证书

姓名: _____ 电话: _____ 地址: _____

商品: _____ 型号: _____ 购买日期: _____ 年 ____ 月 ____ 日

维修记录栏 (由维修员填写)	维修员签名	日期



扫一扫，了解更多产品
Scan for more
product information

广东省电声工程技术研究开发中心 广东得胜电子有限公司制造

地址：广东省惠州市博罗县龙溪街道富康一路2号
服务热线：400 6828 333 传真：0752 6383950
邮箱：xs@takstar.com
网址：www.takstar.com

Designed & Manufactured by:

Guangdong Takstar Electronic Co., Ltd.
Address: No.2 Fu Kang Yi Rd., Longxi Boluo
Huizhou, Guangdong 516121 China
Tel: 86 752 6383644 Fax: 86 752 6383952
Email: sales@takstar.com
Website: www.takstar.com