

一. 前言

欢迎使用ELA-121F防水线性阵列音箱,配套ELA-181F防水超低音箱,该系列音箱主要应用于演出、教堂、体育场馆、大型多功能厅等较大扩声场合。常规的单只全频音箱,以声源类型来区分属“点声源”,在声波传播过程中,声能量在空气中传播产生衰减随距离增加一倍而造成声压衰减6dB;而线性阵列音箱系统,利用合理的声学构造并结合号角的高指向性设计,属“线性声源”,且灵敏度高、声压大,指向性强,声压随距离增加一倍仅衰减3dB,由此可见更适应听众数量较多、面积较大的扩声场合使用,加上采用数字处理器中的电子分频功能进行分频,使系统具备更出众的音质。

二. 产品特性

ELA-121F

- 音箱通过IPX6防水认证等级,可全天候使用,箱体表面喷涂聚脲漆,防水防潮抗腐蚀,延长箱体使用寿命的同时满足更多的使用环境。
- 此款线性阵列音箱系统的全频音箱的高音和中低音扬声器均选用了进口扬声器,12寸中低音单元采用75mm音圈、钕铁硼磁钢,质量轻,灵敏度高,失真度低,频响宽,以确保大功率工作时,具有优美音色;高音扬声器的结构更具特点,由多只钕铁硼磁钢并联组合成的磁回路系统,即利于磁钢散热,也保证磁隙内有充足的磁通量与音圈产生磁感应;采用高分子材料制成的高音膜片,具有柔和的高频特征,在大声压扩声环境中,高频听感不躁、不刺、不烈;号角采用BMC材料(玻璃钢与树脂等多种混合材料)压制而成,表面再喷特殊光亮漆,具有机械强度高(不易产生低频共振)、声学特性好等优点。号角形状开口大、深度长,能充分放大高频声压、拓远有效传播距离、并控制好指向性。
- 音箱系统结合电子分频,免去了内置分频的音质损耗,使音箱整体具有较高的灵敏度、准确的中频表现和优异的高频解析力。

ELA-181F

- 音箱通过IPX6防水认证等级,可全天候使用,箱体表面喷涂聚脲漆,防水防潮抗腐蚀,延长箱体使用寿命的同时满足更多的使用环境。
- 该款超低音箱选用了灵敏度较高的18寸超低音单元,选用国内性能领先的航天磁钢;音箱箱体采用导相式结构,此款单18寸超低音音箱的铝吊挂件与ELA-121F全频音箱可连接吊挂安装。
- 该款超低音箱选用了一只灵敏度较高的18寸进口纸盆超低音单元,选用国内性能领先的航天磁钢;音箱箱体结构方面,采用导相式设计,低频扬声器灵敏度高,声压足,动态大,力度和爆发力表现上佳。

三. 音箱与功放连接示意图

图1

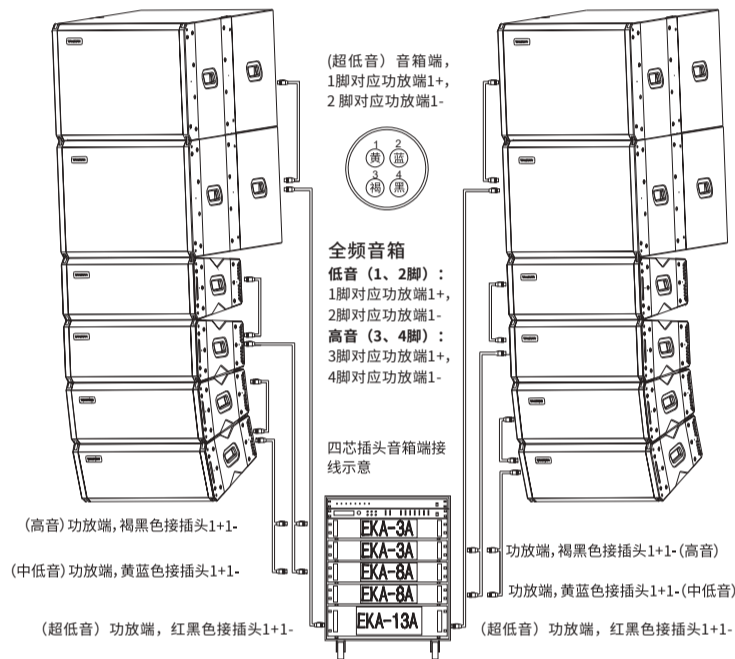

- 1.左、右声道各两只超低音、四只线性阵列全频音箱。超低音每只8Ω,用连接线连接两只超低音,并联后总阻抗值4Ω。全频音箱每两只音箱连接一条连接线,并联后,低音和高音分别是阻抗值为4Ω。
- 2.采用两台300W二通道功放(拨到单通道档),一台用于左声道高音,一台用于右声道高音;两台800W二通道功放(单通道档),一台用于左声道中低音,一台用于右声道中低音;一台1300W二通道功放(立体声档)用于四只超低音音箱。
- 3.超低音配二芯音箱线以红黑线为例,两端接音箱插头的1脚2脚,黑色对应2脚。
- 4.全频音箱的音箱线必须使用四芯音箱电缆线接四芯插头,例如四芯线内有褐、黑、黄、蓝四种颜色,每两种颜色线为一组(若线材实际颜色与说明书不同,取任意两色为一组),例如黄、蓝色线分别接插头的1脚2脚(用于接中低音),褐、黑色线接3脚4脚(用于高音),每条线统一接法,若接错,音箱音质不正常的同时存在导致烧毁高音扬声器的可能。以上是音箱线接音箱的一端。

图2: (系统连接示意图)



图3:



图4:

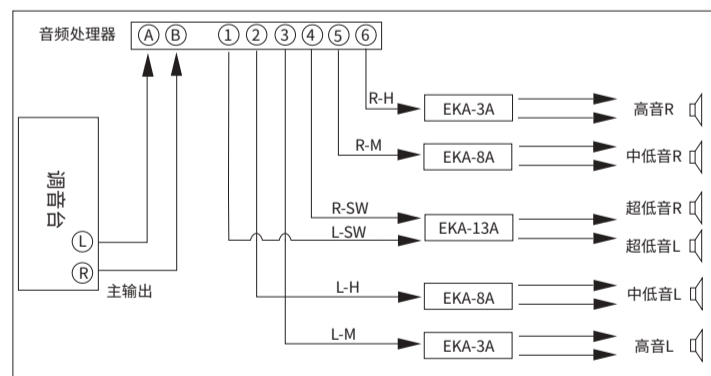

5. 两种不同安装方式的覆盖角度示意图 (如图3、图4)。

图5:

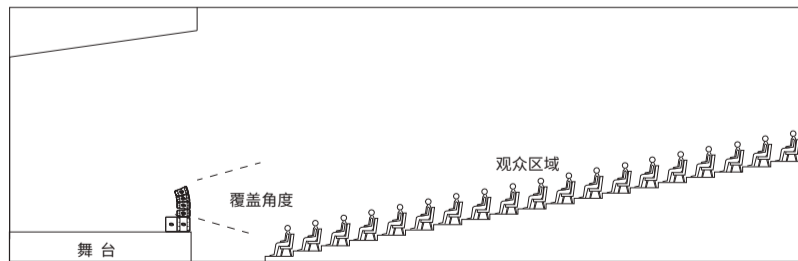
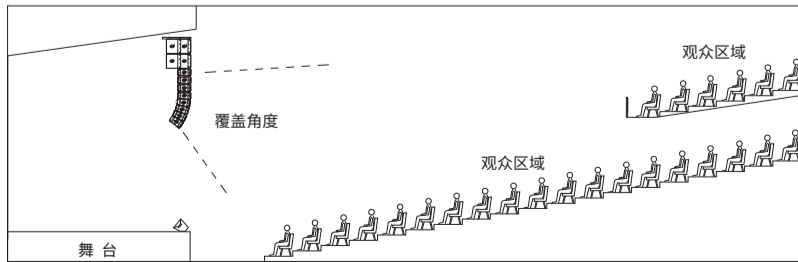
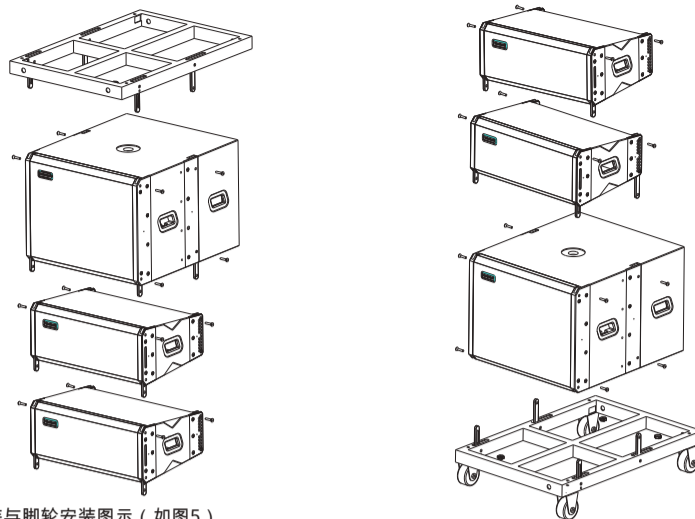

6. 吊挂安装与脚轮安装图示 (如图5)

四. 注意事项

- 1.确保功率放大器和音箱的功率、阻抗相匹配,失衡搭配可导致扬声器损坏或损坏音质。
- 2.音箱吊挂或倒置于舞台使用时,全频音箱必须调成弧形面,具体弧度视现场而定(如图3、图4)
- 3.音箱的安装需由专业工程人员进行,应固定牢靠。
- 4.搬运音箱时,请小心轻放,保护好音箱不受损坏。
- 5.非专业技术人员请勿私自接线或使用设备。
- 6.系统的音质效果取决于调试者的专业技术、音乐鉴赏水平等综合能力。
- 7.音箱使用完后,音箱上的插销、连接杆固定在音箱上,以免丢失。

五. 技术参数

| 类别 | 项目 | 超低音 | 中低音扬声器 | 高音 | |
|-------|-----------------------|-------------------------------|--|------------------|----------------|
| 扬声器参数 | 外径 | 18寸 | 12寸 | 123mm | |
| | 音圈直径 | 100mm | 75mm | 65mm | |
| | 磁钢 | 铁氧体220mm | 钕铁硼 | 钕铁硼 | |
| | 灵敏度 | 99dB | 98dB | 109dB | |
| | 额定阻抗 | 8Ω | 8Ω | 8Ω | |
| | 频率响应 | 30Hz-1000Hz | 65Hz-4kHz | 0.7kHz-18kHz | |
| 音箱参数 | 音箱型号 | ELA-181F | ELA-121F | | |
| | 用量 | 1PC | 1PC | 1PC | |
| | 音箱阻抗 | 8Ω | 8Ω | 8Ω | |
| | 指向性 | 无 | 100°x 8° | | |
| | 额定功率 | 1300W(AES) | 600W(AES) | 150W(AES) | |
| | 匹配功放 | 1300W*2, 两只音箱并联 | 800W x 2, 两只音箱并联 | 300W x 2, 两只音箱并联 | |
| | 分频范围 | | 25Hz-100Hz | 50Hz-1700Hz | 1700Hz-18000Hz |
| | | | 以上为建议值,超低与中低音分频选在80-130Hz范围内均可,但频率要相互衔接。 | | |
| | 滤波选择 | 高通Bw-24、低通Bw-24 | 高通Bw-24、低通BW-48 | 高通Lk-24、低通Lk-24 | |
| | 板材 | 25+18mm夹板 | 18mm夹板 | | |
| 尺寸 | 650*706*510mm (W*D*H) | 450 x 650 x 329mm (W x D x H) | | | |
| 接线座 | 2PCS, IN:1脚2脚 | IN:中低音1脚2脚,高音3脚4脚 | | | |
| 线材 | 二芯音频电缆线 | 四芯音频电缆线 | | | |
| 防水等级 | | IPX6 | | | |

注:以上数据由得胜实验室测试得到,并拥有最终解释权!

六. 标准配置

田字架(每只含卸扣4只、脚轮4只,插销4只,吊带2条,连接杆4条,M12螺丝螺母4套),共 ()只;
每列线性阵列音箱配一只田字架。

全频音箱(每只含前后连接杆共4条、插销6只),共 ()只;

二芯音箱线,每两只超低音音箱配一条(两端接四芯插头),共()条,每条长0.7米;

超低音音箱(每只含前后连接杆共4条、插销6只),共()只;

四芯音箱线,每两只全频音箱配一条,共()条、每条长0.35米; 两端接四芯插头。

每两只全频音箱配一条,共()条、每条长()米(用于音箱与功放连接,选配);

说明书1张(每个独立包装内放一份)。

备注:视每次订单数量或使用数量而定,出厂前填写以上数据。

七. 安全警示

为避免电击、高温、着火、辐射、爆炸、机械危险以及使用不当等可能造成的人身伤害或财产损失,使用本产品,请仔细阅读并遵守以下事项:

- 1.使用产品时请确认所连接设备与本产品功率是否匹配以及合理调整音量大小,不要在超过产品功率及大音量下长时间使用,以免造成产品异常和听力损伤;
- 2.使用中若发现有异常(如冒烟、异味等),请立即关闭电源开关并拔掉电源插头,然后将产品送经销商检修;
- 3.本产品及配件都应放置在室内干燥通风处,勿长期存放在潮湿、灰尘多的环境,使用中避免靠近火源、雨淋、进水、过度碰撞、抛掷、振动本机及覆盖通风孔,以免损坏其功能;
- 4.若产品需要固定于墙壁或天花板上时,请确保固定到位,防止因固定强度不足导致产品发生坠落危险;
- 5.使用该产品时需遵守相关安全规定,法律法规明确禁止使用场合请勿使用本机,以免导致意外事故;
- 6.请不要自行拆机改装或维修,以防止出现人身伤害,如有问题或服务需求请联系当地经销商跟进处理。

注意事项:

- 1.本单为保修凭证,请用户妥善保管,如有遗失,恕不保修或退换。
- 2.保修期限:购买之日起十二个月内。
- 3.除了不可抗力事件损坏外,由本公司负责,免费维修。
- 4.如属保管不善或使用不当造成的损坏,维修点将酌收费用。
- 5.擅自拆卸维修者,不予保修。
- 6.以上保修条款仅限于中国市场适用(不含港澳台地区)。

产品服务保证书

姓名: _____ 电话: _____ 地址: _____
商品: _____ 型号: _____ 购买日期: _____ 年 _____ 月 _____ 日

| 维修记录栏 (由维修员填写) | 维修员签名 | 日期 |
|----------------|-------|----|
| | | |
| | | |
| | | |
| | | |
| | | |

◆广东得胜电子有限公司 ◆电话: 400-6828-333 ◆地址: 广东省惠州市博罗县龙溪街道富康一路2号



I. Preface

Introducing the ELA-121F waterproof line array speaker, paired with the ELA-181F waterproof subwoofer. Designed for larger venues like concerts, churches, stadiums, and multipurpose halls, this system provides high sensitivity, powerful sound, and focused coverage. Unlike traditional "point source" speakers that experience a 6dB attenuation for every doubling of distance, the linear array design reduces this attenuation to just 3dB. With digital signal processing and electronic crossover, the system delivers exceptional sound quality.

II. Features

ELA-121F

- IPX6 waterproof certification, for all-weather use. Polyurethane-coated cabinet extends lifespan, resistant to moisture and corrosion.
- Imported drivers: 12-inch MFLF with 75mm voice coil, neodymium magnet for lightweight, high-sensitivity, wide frequency response. HF driver uses parallel neodymium magnet structure for efficient heat dissipation and magnetic flux, delivering smooth, non-fatiguing sound. Polymer diaphragm for smooth HF, and BMC horn with glossy coating for high strength, excellent acoustics and directionality.
- Electronic crossover eliminates sound quality loss associated with built-in crossovers, ensuring high sensitivity, accurate mid-range and HF resolution.

ELA-181F

- IPX6 waterproof certification, for all-weather use. Polyurethane-coated cabinet extends lifespan, resistant to moisture and corrosion.
- High-sensitivity 18-inch driver with advanced aerospace-grade magnetic materials. Reflex port design. Compatible with ELA-121F full-range speaker for seamless hanging installation.
- Features a highly sensitive 18-inch imported paper cone driver and leading domestic aerospace-grade magnets. Ported cabinet design for optimal low-frequency response, resulting in high sensitivity, strong sound pressure, and excellent dynamic performance.

III. Wiring Speaker & Power Amp

Fig. 1

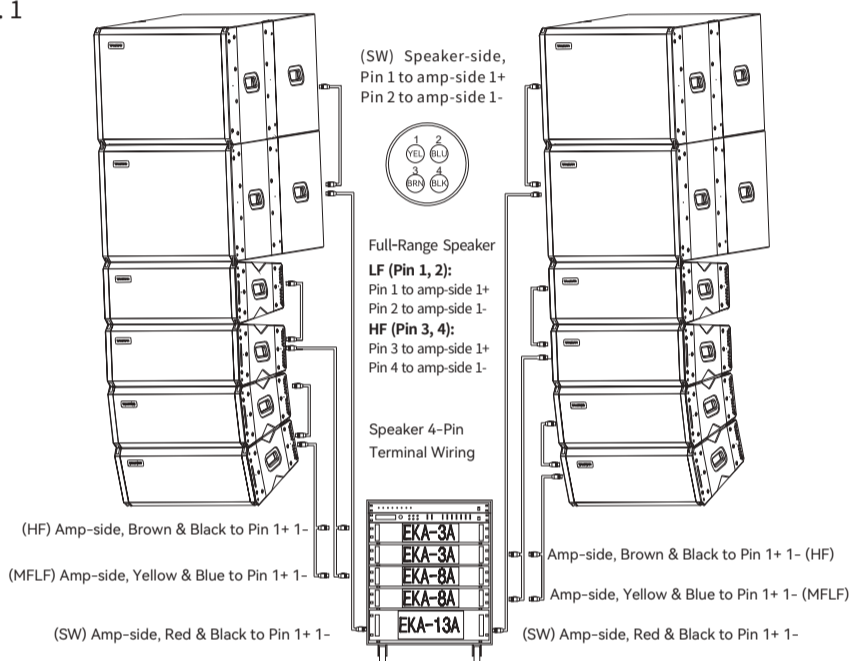

1. Left and right channels each with 2 subwoofers and 4 full-range speakers. Each subwoofer (SW) is 8Ω, connect pairs in parallel for 4 Ω total impedance. And connect remaining four full-range speakers in pairs in parallel for 4Ω LF and HF driver impedance.
2. Use the following power amplifiers: Two 300W 2-channel amplifiers (mono mode) for left and right highs (HF). Two 800W 2-channel amplifiers (mono mode) for left and right mids/low(MFLF). One 1000W 2-channel amplifier (stereo mode) for all four subwoofers.
3. Subwoofers use two-core audio cable, red and black wires for instance, connected to speaker terminal Pin 1 and Pin 2, with black wire to Pin 2
4. Full-range speaker must use four-core cables with 4-pin connector. For example, if the four cores are of brown, black, yellow and blue colors, use two colors as a pair (choose any two colors in pairs if different from the example here). Say, yellow & blue wires each to connector Pin 1 & 2 (for MFLF), brown & black to Pin 3 & 4 (for HF), and follow the same color-combination wiring across all speakers. Make sure to connect the cables correctly to avoid damaging the speakers or amplifier.

Fig. 2: (System Connection Diagram)

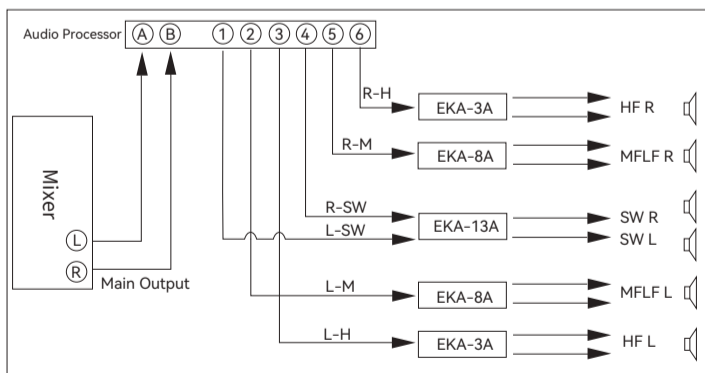

Fig. 3:

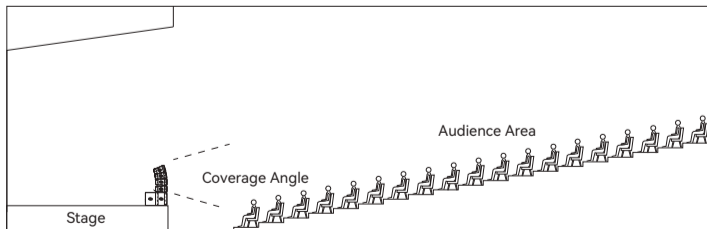
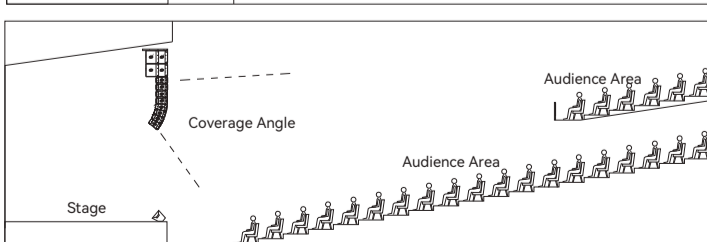
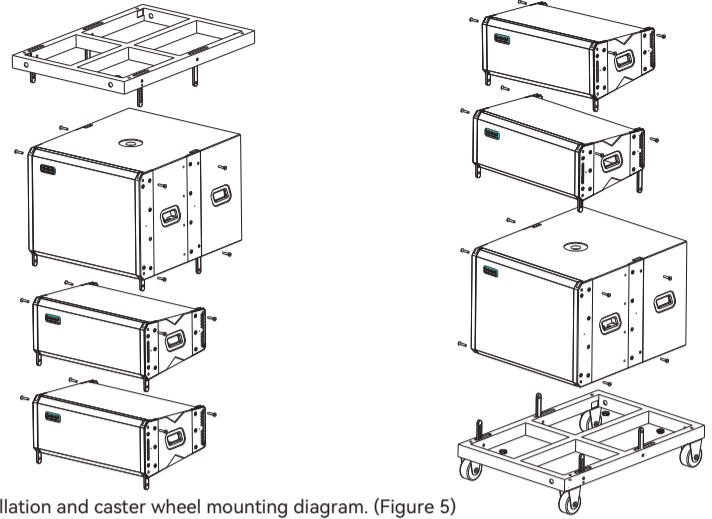

Fig. 4:



5. Coverage angle of two different installation methods as shown in Figs. 3-4.

Fig. 5:



6. Hanging installation and caster wheel mounting diagram. (Figure 5)

IV. Cautions

1. Match amplifier power and impedance to speakers to prevent equipment damage or degraded sound quality.
2. For suspended or inverted stage installation, adjust full-range speakers to required curvature (Figs. 3-4).
3. Secure speakers firmly in place by qualified installers.
4. Handle speakers carefully to prevent transport damage.
5. Leave wiring and setup to qualified technicians.
6. System sound depends on the tuning skills of the technician.
7. Secure pins and fasteners after use to prevent loose or lost parts.

V. Specifications

| Type | Item | Subwoofer (SW) | MFLF Driver | HF Driver (Tweeter) | |
|-------------------|-----------------------|--|------------------------------------|------------------------------------|--------------|
| Driver Spec | Outer Dia. | 18" | 12" | 123mm | |
| | Voice Coil Dia. | 100mm | 75mm | 65mm | |
| | Magnet | Ferrite 220mm | NdFeB | NdFeB | |
| | Sensitivity | 99dB | 98dB | 109dB | |
| | Rated Impedance | 8Ω | 8Ω | 8Ω | |
| | Frequency Response | 30Hz-1000Hz | 65Hz-4kHz | 0.7kHz-18kHz | |
| Speaker Spec | Model | ELA-181F | ELA-121F | | |
| | Quantity | 1PC | 1PC | 1PC | |
| | Impedance | 8Ω | 8Ω | 8Ω | |
| | Directivity | Null | 100° × 8° | | |
| | Rated Power | 1300W (AES) | 600W (AES) | 150W (AES) | |
| | Matching Power Amp | 1300W * 2, two speakers in parallel | 800W * 2, two speakers in parallel | 300W * 2, two speakers in parallel | |
| | Crossover Range | 25Hz-100Hz | 50Hz-1700Hz | 1700Hz-18000Hz | |
| | | Above is the recommended value, but subwoofer and MFLF crossover can be selected between 80-130Hz as long as their frequencies are continuous. | | | |
| | Filter Preset | High Pass BW-24, Low Pass BW-24 | High Pass BW-24, Low Pass BW-48 | High Pass LK-24, Low Pass LK-24 | |
| | Panel | 25+18mm Plywood | | | 18mm Plywood |
| Dimensions | 650*706*510mm (W*D*H) | | 450*650*329mm (W*D*H) | | |
| Connector | 2PCS, IN: Pin 1 & 2 | | IN: MFLF Pin 1 & 2, HF Pin 3 & 4 | | |
| Cable | Two-Core Audio Cable | | Four-Core Audio Cable | | |
| Waterproof Rating | IPX6 | | | | |

Note: The above data are measured by Takstar laboratory which has the final interpretation right!

VI. Standard Configuration

| |
|---|
| Rigging Frames: Each contains 4 shackles, 4 castors, 4 pins, 2 slings, 4 connecting rods, and 4 sets of M12 screws and nuts, in total () PCS; Each line array should be supplied with one piece of rigging frame. |
| Full-Range Speakers: Each speaker includes a total of 4 front and rear connecting rods and 6 quick-release pins; in total () PCS |
| Two-Core Speaker Cable (four-pin connector on both ends): One for every two subwoofers, each is 0.7m long, in total () PCS. Subwoofer (each contains 4 connecting rods, 6 pins): in total () PCS. |
| Four-Core Speaker Cable: One for every two full-range speakers, each is 0.35m long, in total () PCS. Four-pin connectors on both ends. |
| Audio Cable: One for every two full-range speakers, each at () m long, in total () PCS. (Used for connection between speaker and amplifier; optional). |
| User Manual (one in each standalone packaging) |

Note: The above data will be filled out prior to shipment, depending on the quantity or intended usage specified in each order.

VII. Safety Instructions

To avoid electric shock, overheat, fire, radiation, explosion, mechanical risk and injury or property loss due to improper use, please read and observe the following items before use:

1. Please check if the power of the connected equipment matches with that of this product before operation. Adjust the volume to proper level during operation. Do not operate at over-power or high-volume level for extended time to avoid product malfunction or hearing impairment.
2. If there is any abnormality during use (e.g., smoke, strange odor), please kill the power switch and unplug from power source, then send the product to the local after-sales service for repair.
3. Keep this product and its accessories in a dry and ventilated area. Do not store in a humid or dusty area for extended time. Keep away from fire, rain, liquid intrusion, bumping, throwing, vibrating, or from blocking any ventilation openings, to prevent malfunction.
4. The product must, when installed on walls or ceilings, be fixed firmly in place at adequate strength to prevent from falling.
5. Please abide by safety rules during operation. Do not use the product in places prohibited by laws or regulations to avoid accident.
6. Do not disassemble or repair the product by yourself to avoid injury. If you have any questions or require any services, please contact our local after-sales service.