

一. 前言

欢迎使用得胜ESA-081线性阵列音箱，配套ESA-151次低音音箱，该系列音箱主要应用于小型演出、教堂、体育馆、小型多功能厅等大型扩声场合。常规的单只全频音箱，以声源类型来区分属“点声源”，在声波传播过程中，声能量在空气中传播产生衰减，且灵敏度、声压大、指向性强，声压随距离增加一倍仅衰减3dB，更适合听众数量较多、面积较大的扩声场合使用。为了更好的了解使用本产品，请您在使用前仔细阅读本说明书。若存在有疑问或者您有宝贵的建议，可通过拨打得胜官方服务热线400 6828 333或微信扫描二维码关注得胜官方公众号与我们联系。

二. 产品特性

ESA-081

- 单元结构上由8寸50芯纸盆中低音和44芯进口压缩驱动器高音组成；
- 低音采用弹性与耐疲劳性俱佳并附特殊涂层处理的布边折环，中低频反应迅速、动态足；
- 高音采用聚酰亚胺膜片，高频透亮平滑、细腻耐听，细节表现力好；
- 配上特定指向性平面波导号角，能有效控制垂直指向性，多只组合近似线性声源，远距离传播衰减减小；
- 磁路采用对称设计，谐波失真小，还原声音的真实与纯净；
- 分频器元件采用了损耗值较低的无氧铜空心电感、高品质聚丙烯及聚酯电容，使分频网络稳定，音质出众；
- 箱体采用梯形结构，内壁贴附吸音棉能减少驻波的产生，使中低频在听感上表现得更干净，频响上更平坦；箱体结构紧凑，采用吊挂件连接，配备磁吸式插销，垂直角度-4°至0°至10°八挡可调，可根据场地大小灵活调节辐射角度。

ESA-151

- 单元结构上由单15寸100芯纸盆布边次低音扬声器组成；
- 扬声器采用耐疲劳性较好的布边折环，低频干净有力；
- 磁路采用对称设计，谐波失真小；
- 采用长冲程音圈，电声转换效率较高；
- 箱体采用倒相式结构，精确的声学仿真设计确保较高的低频效率和响应速度；
- 箱体结构紧凑，采用铝吊挂件连接，可根据场地大小灵活选择音箱数量。

三. 音箱与功放连接示意图

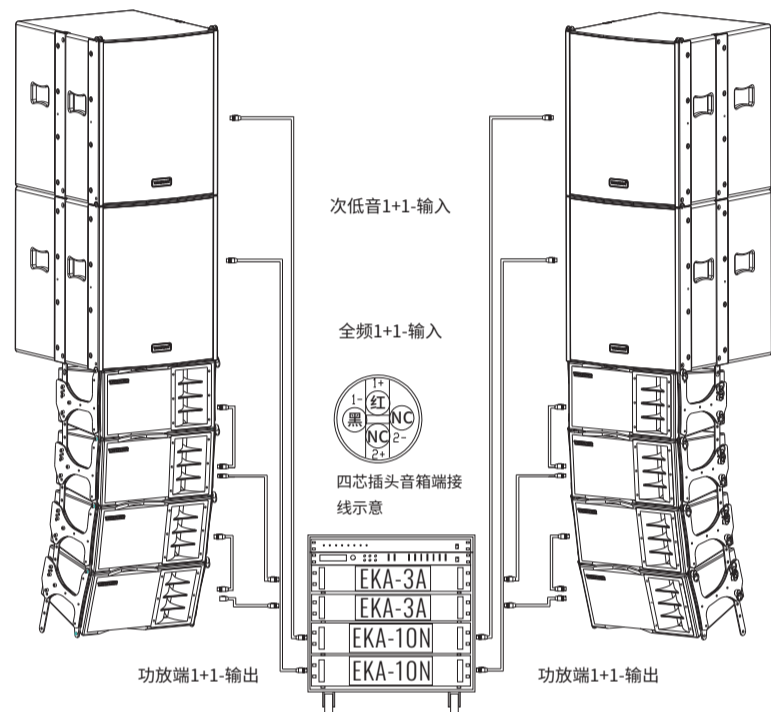

- 1.左、右声道各两只次低音音箱、四只线性阵列全频音箱。两只次低音音箱阻抗为每只8Ω；两只线性阵列全频音箱为一组，用1条连接线并联，全频音箱每只8Ω，并联后，阻抗值为4Ω；
- 2.采用两台300W二通道功放（拨到单通道挡位），建议一组全频音箱接专业功放一个通道，两台1000W二通道功放（单通道挡位）建议一个次低音音箱接功放的一个通道；
- 3.次低音配二芯音箱线，以红黑线为例，两端接音箱插头的1+、1-，黑色对应1-；
- 4.全频音箱的音箱线使用二芯音箱线，以红黑线为例，两端接音箱插头的1+、1-，黑色对应1-。

全频音箱角度调节方式

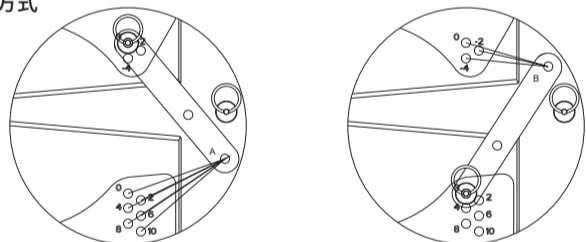

全频音箱之间用吊挂件四点连接，其中后板吊挂件通过插销可进行垂直角度-4°至0°至10°八挡可调（见上图）：

1. 0°-10°调节方法：B端固定插入0度孔位，A端插入相应所需角度孔位（如图1），如需要调节8度，B插入0度的孔，A插入8度；
2. -2°/-4°调节方法：A端固定插入0度孔位，B端插入相应所需角度孔位（如图2），如需要调节-2度，A插0度孔，B插入-2度的孔。

系统连接示意图

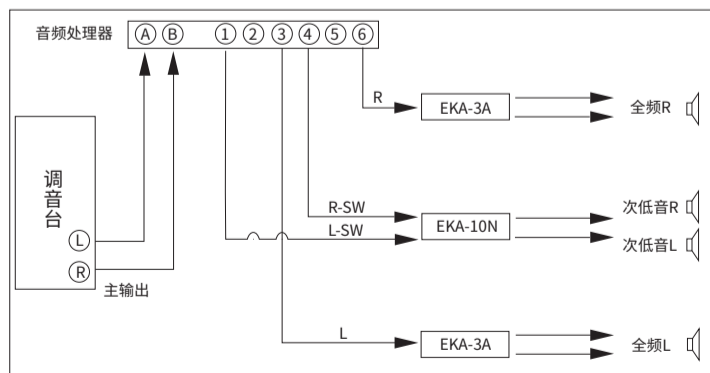

1. 两种不同安装方式的覆盖角度示意图：

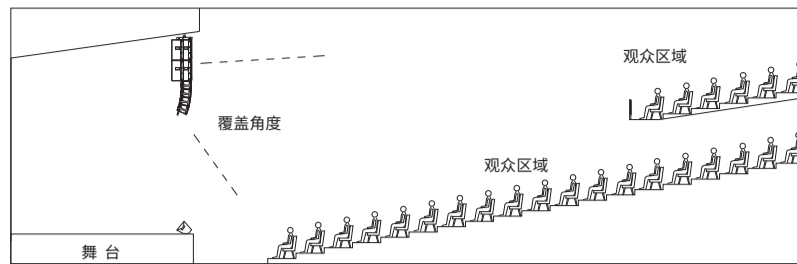
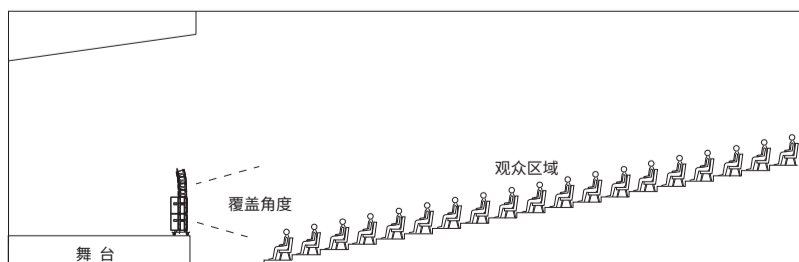

2. 吊挂安装与脚轮安装图示：

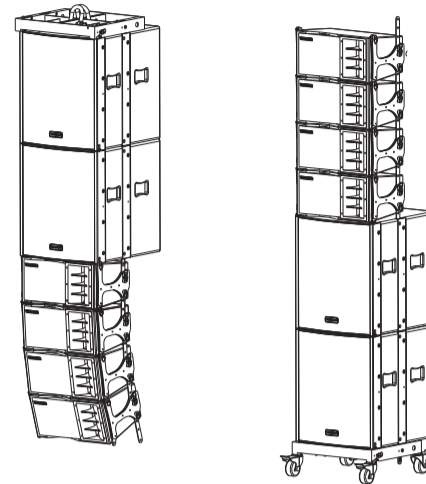

(吊/挂装方式承重≤1000斤)
(另：加4个轮子方便移动)

四. 注意事项

- 1.为保证吊挂安全，单边最多不超过16只全频音箱；
- 2.需确保功率放大器和音箱的功率、阻抗相匹配，失衡搭配可导致设备损坏或音质效果不佳；
- 3.音箱的安装需由专业工程人员进行，应固定牢靠，并选择安装在不易碰触的位置；
- 4.使用时，音箱高音号角朝向听众区域，以确保获得最佳听感；
- 5.搬运音箱过程中，注意小心轻放，保护好音箱，以防止音箱受到撞击或损坏；
- 6.音箱使用完后，音箱上的插销、连接杆固定在音箱上，以免丢失。

五. 技术参数

类别	项目	次低音	中低音扬声器	高音
扬声器参数	外径	15寸	8寸	1.75寸
	音圈直径	100mm	50mm	44mm
	磁钢	铁氧体200mm	铁氧体160mm	铁氧体120mm
音箱参数	音箱型号	ESA-151	ESA-081	
	音箱阻抗	8Ω	8Ω	
	频率响应	60Hz-500Hz	75Hz-20kHz	
	分频模式	无	无源二分频	
	分频点	无	1600Hz	
	灵敏度	103dB	96dB	
	最大声压级	133dB	120dB	
	额定功率 (AES)	1000W	300W	
	指向性	无	H120°×V10°	
	匹配功放	1000W*1—一只音箱	300W*2 两只音箱并联	
	分频频率范围	60Hz-200Hz	110Hz-20kHz	
	外置滤波选择	低通BW-24、高通BW-24	低通BW-24、高通BYPASS	
	表面处理	黑色聚亚安酯小点漆		
	安装方式	吊挂件连接	吊挂件连接，垂直角度-4°-0°-10°八挡可调	
板材	18mm夹板	15mm夹板		
尺寸	462*530*545mm (W*D*H)	455*279*250mm (W*D*H)		
净重	约29.5KG	约15KG		
接线方式	2PCS,IN:1+/1-	2PCS,IN:1+/1-		
线材	两芯音频电缆线	两芯音频电缆线		

注：以上数据由得胜实验室测试得到，并拥有最终解释权！

六. 标准配置

田字架（每只含U型扣4只，插销4只，吊带2条，连接杆4条），每列线性阵列音箱配一只田字架
全频音箱（每只含前后连接杆共2条，插销6只）
次低音音箱（每只含前后固定连接杆共4条，插销4只）
说明书（每个独立包装内含一份）

备注：视每次订单数量或使用数量而定，出厂前填写以上数据。

七. 安全警示

为避免电击、高温、着火、辐射、爆炸、机械危险以及使用不当等可能造成的人身伤害或财产损失，使用本产品前，请仔细阅读并遵守以下事项：

1. 使用产品时请确认所连接设备与本产品功率是否匹配以及合理调整设备音量大小，不要在超过产品功率及大音量下长时间使用，以免造成产品异常；
2. 使用中若发现有异常（如冒烟、异味等），请立即关闭电源开关并拔掉电源插头，然后将产品送售后服务网点检修；
3. 本产品及配件都应放置在室内干燥通风处，勿长期存放在潮湿、灰尘多的环境，使用中避免靠近热源，雨淋、进水、过度碰撞、抛掷、振动本机及覆盖通风孔，避免损坏其功能；
4. 若产品需要固定于墙壁或天花板上时，请确保固定到位，防止因固定强度不足而导致产品发生跌落危险；
5. 使用该产品时需遵守相关安全规定，法律法规明确禁止使用场合请勿使用产品，以免导致意外事故；
6. 请不要自行拆机改装或维修，以防止出现人身伤害，如有问题或服务需求请联系当地售后服务网点跟进处理。

注意事项：

1. 本单为保修凭证，请用户妥善保管，如有遗失，恕不保修或退换。
2. 保修期限制：购买之日起十二个月内。
3. 除了不可抗力事件损坏外，由本公司负责，免费维修。
4. 如属保管不善或使用不当造成的损坏，维修点将酌情收费。
5. 擅自拆卸维修者，不予保修。
6. 以上保修条款仅限于中国市场适用（不含港澳台地区）。

产品服务保证书

姓名：_____ 电话：_____ 地址：_____

商品：_____ 型号：_____ 购买日期：_____年__月__日

维修记录栏（由维修员填写）	维修员签名	日期

◆广东得胜电子有限公司 ◆电话：400-6828-333 ◆地址：广东省惠州市博罗县龙溪街道富康一路2号



I. Introduction

Introducing the ESA-081 line array speaker, paired with the ESA-151 subwoofer. Designed for medium-sized amplification scenarios such as small-scale performances, churches, stadiums, small multipurpose halls, and similar venues, this system provides high sensitivity, powerful sound, and focused coverage. Unlike traditional "point source" speakers that experience a 6dB attenuation for every doubling of distance, the linear array design reduces this attenuation to just 3dB, making it suitable for large venues with many audiences. Read this manual thoroughly before use to have a better understanding of the product. If you have any questions or suggestions, please contact our local sales outlet.

II. Features

ESA-081

- 8" paper cone woofer with 50mm coil + imported compression tweeter with 44mm coil.
- Fatigue-resistant specially-coated woofer spider surround for quick response and wide dynamics.
- Polyester tweeter diaphragm for bright, smooth, detailed highs.
- Waveguide horn controls directivity for near-linear summation over distance.
- Symmetrical magnet circuit for low distortion.
- Low-loss crossover capacitors (CBB/PET) and inductors (OFC air-core) for stable sound quality.
- Trapezoidal enclosure with acoustic batting reduces standing waves for cleaner midrange. Compact and adjustably mounted via flybars and magnetic latches from -4° to 10° in 8 steps for optimized venue coverage.

ESA-151

- Single 15-inch paper cone low-frequency driver with 100mm voice coil.
- Cone with fatigue-resistant cloth surround delivers deep, powerful lows.
- Symmetrically designed magnetic circuit results in low harmonic distortion.
- Long excursion voice coil provides high transducer efficiency.
- Reflex port design with precise acoustic modeling ensures high bass efficiency and response times.
- Compact enclosure connects together easily with aluminum flybars for flexibility in determining the number of units based on venue size.

III. Wiring Speaker & Power Amp

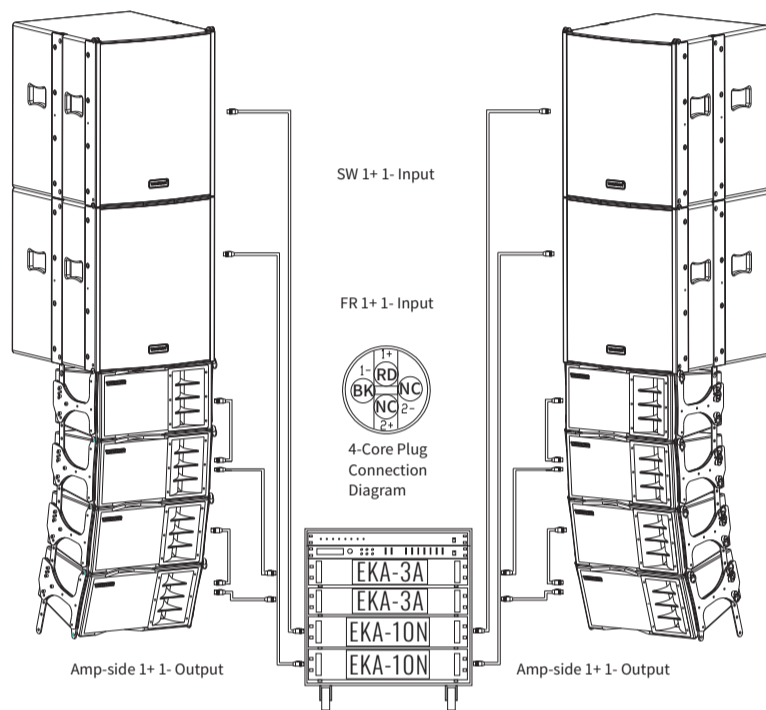

1. Left and right channel each consists of two subwoofers (8Ω impedance each) and four full-range line array speakers. Connect two full-range speakers (8Ω impedance each) in parallel using one cable for a combined impedance of 4Ω.
2. Use two 300W dual-channel amplifiers (set to bridged mono mode), and connect a pair of full-range speakers to one channel of the amplifier. Connect one subwoofer speaker to one channel of two 1000W dual-channel amplifiers (set to bridged mono mode).
3. Connect the subwoofers using a two-core speaker cable, using the red wire for positive (1+) and the black wire for negative (1-).
4. Connect the full-range speakers using a two-core speaker cable, using the red wire for positive (1+) and the black wire for negative (1-).

Adjusting Angle of Full-Range Speakers

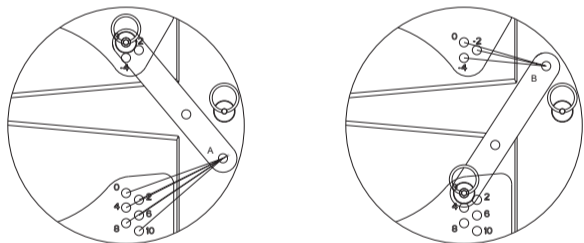

The full-range speakers are connected using a four-point suspension mechanism. The rear panel suspension bracket allows vertical angle adjustment in eight positions: -4° to 0° to 10° (see above diagrams).

- a) 0° to 10° adjustment: Insert the B-end into the 0° position, and insert the A-end into the desired angle position (refer to Figure 1). For an 8° adjustment, insert B into the 0° hole and A into the 8° hole.
- b) -2°/-4° adjustment: Insert the A-end into the 0° position, and insert the B-end into the desired angle position (refer to Figure 2). For a -2° adjustment, insert A into the 0° hole and B into the -2° hole.

System Connection Diagram

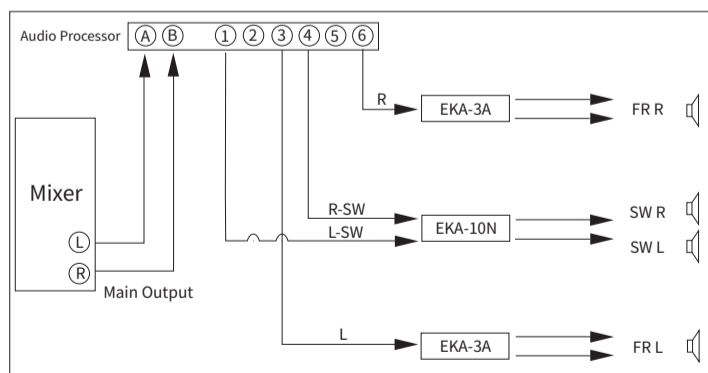

1. Coverage angles for two types of installation:

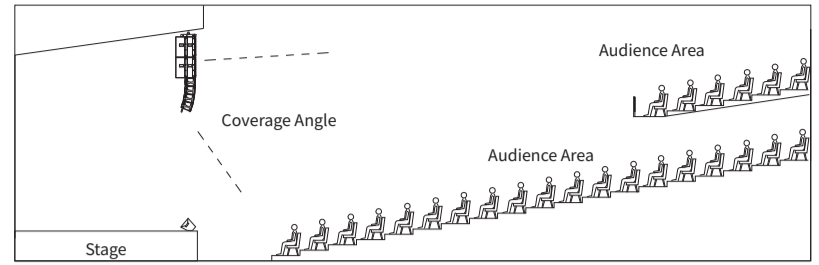
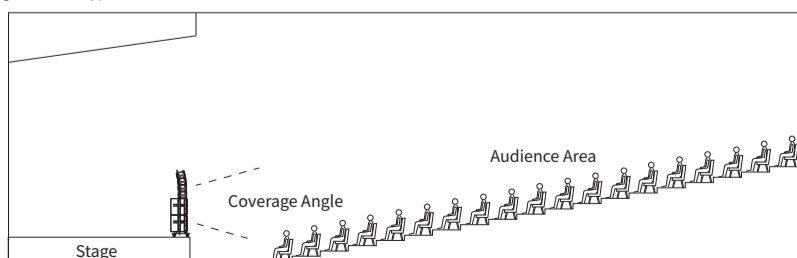

2. Rigging and caster wheel mounting:

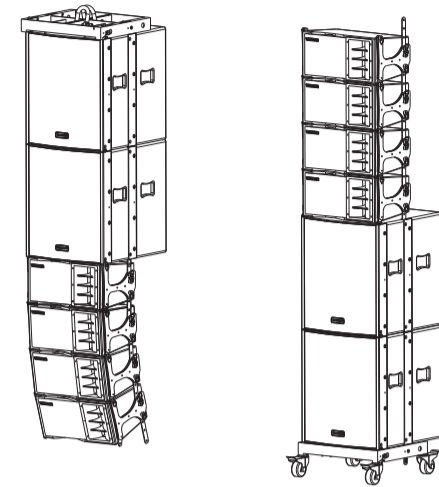

(Rigging Load ≤ 500kg)

(Add 4 casters for mobility)

IV. Cautions

1. To ensure safe suspension, do not exceed a maximum of 16 full-range speakers on one side.
2. Ensure proper matching of power and impedance between the power amplifier and speakers. Mismatched combinations can result in equipment damage or poor sound quality.
3. Installation of the speakers should be carried out by professional technicians, ensuring secure fixation and placement in areas that are not easily accessible.
4. During use, position the speakers with the tweeter horn facing the audience area to achieve optimal sound experience.
5. Handle the speakers with care during transportation to prevent impact or damage.
6. After use, secure the locking pins and connecting rods on the speakers to prevent loss.

V. Technical Parameters

Type	Item	SW Subwoofer	MFLF Woofer	HF Tweeter
Driver Spec	Outer Dia.	15"	8"	1.75"
	Voice Coil Dia.	100mm	50mm	44mm
	Magnet	Ferrite 200mm	Ferrite 160mm	Ferrite 120mm
	Model	ESA-151	ESA-081	
Speaker Spec	Impedance	8Ω	8Ω	
	Frequency Response	60Hz-500Hz	75Hz-20kHz	
	Crossover Mode	Null	Passive two-way	
	Crossover Point	Null	1600Hz	
	Sensitivity	103dB	96dB	
	Max SPL	133dB	120dB	
	Rated Power (AES)	1000W	300W	
	Directivity	Null	H120°×V10°	
	Amp Match	1000W × 1, one speaker	300W × 2, two speakers in parallel	
	Crossover Range	60Hz-200Hz	110Hz-20kHz	
	External Filter	Low Pass BW-24, High Pass BW-24	Low Pass BW-24, High Pass BYPASS	
	Finish	Black Polyurethane Paint		
Installation	Suspension Bracket	Suspension Bracket, -4°-0°-10° Vertical Angle Adjust (8 Steps)		
Panel	18mm Plywood	15mm Plywood		
Dimensions	462*530*545mm (W*D*H)	455*279*250mm (W*D*H)		
Net Weight	About 29.5KG	About 15KG		
Wiring Method	2PCS, IN:1+/1-	2PCS, IN:1+/1-		
Audio Cable	Two-Core Cable	Two-Core Cable		

Note: the above data are measured by Takstar laboratory which has the final interpretation right!

VI. Standard Configuration

Rigging Frame (each contains 4 shackles, 4 pins, 2 slings, 4 connecting rods); each line of speaker array is supplied with one rigging frame.
Full-Range Speaker (each speaker includes a total of 2 front and rear connecting rods and 6 pins)
Subwoofer (each contains 4 front and rear connecting rods and 4 pins)
User Manual (one in each standalone packaging)

Note: the above is subject to the quantity of order or unit intended for use; fill in the amount before shipping out the factory.

VII. Safety Instructions

To avoid electric shock, overheating, fire, radiation, explosion, mechanical risk and injury or property loss due to improper use, please read and observe the following items before use:

1. Please check if the power of the connected equipment matches with that of this product before operation. Adjust the volume to proper level during operation. Do not operate at over-power or high-volume level for extended time to avoid product malfunction or hearing impairment.
2. If there is any abnormality during use (e.g., smoke, strange odor), please kill the power switch and unplug from power source, then send the product to the local after-sales service for repair.
3. Keep this product and its accessories in a dry and ventilated area. Do not store in a humid or dusty area for extended time. Keep away from fire, rain, liquid intrusion, bumping, throwing, vibrating, or from blocking any ventilation openings, to prevent malfunction.
4. The product must, when installed on walls or ceilings, be fixed firmly in place at adequate strength to prevent from falling.
5. Please abide by safety rules during operation. Do not use the product in places prohibited by laws or regulations to avoid accident.
6. Do not disassemble or repair the product by yourself to avoid injury. If you have any questions or require any services, please contact our local after-sales service.