

TAKSTAR® 得胜



M-2R系列 无线一拖二麦克风

M-2R Series Dual-Channel Wireless Microphone System

使用手册 | User Manual

M-2R系列 无线一拖二麦克风

■ 前言

感谢您选购得胜M-2R系列无线一拖二麦克风,为了您能够更好地了解使用本产品,建议您在使用前仔细阅读本说明书。

若存在有疑问或者您有宝贵的建议,可通过拨打得胜官方服务热线400 6828 333或微信扫描二维码关注得胜官方公众号与我们联系。



■ 产品特性

- 采用真分集无线数字导频技术,精确地控制无线信号,高抗干扰,提高信号质量;
- 自动跟踪调频技术,保持稳定的频率输出,提高系统的整体性能和可靠性;
- 42MHz频宽内有1280个可用频点,每个频段32个互不干扰频道,支持16个以上通道使用;
- 系统具有225个地址码可选,20组或User频率组设定;10组频道设定;
- 系统集成自动空闲频道选择,PC联机自动扫描和自动分配频点;
- 自动扫频功能,可快速准确地找出无干扰的空闲信道,简化安装调试工作;
- PC界面控制功能,连接电脑进行操作和监控,更精细更直观,轻松掌控全局;
- 内置4种EQ均衡模式设置,用户可根据具体情况进行选用;
- 3种静噪阈值功能,提高通信的清晰度和稳定的通信效果,减少系统噪声和干扰;
- 支持储存设置和读取程式,可储存10种设置状态;
- 独立监听输出,实时监控拾录状况,同步监听调节输出音量;
- 发射机有高、中、低三种功率工作状态,根据使用距离进行选择;
- 接收机和发射机有5段电池电量显示和5段音频电平显示;
- 接收机支持用户名设置功能,可选取6个字符(0-9和A-Z)设置使用者名称;
- 采用双飞梭旋转开关,下拉式菜单控制,操作快速方便;
- 接收机采用OLED显示屏,发射机采用LCD屏显,工作状态一目了然。

■ 适用范围

适用高要求的工程、音乐会、公共广播环境、演艺场合等

M-2R系列 无线一拖二麦克风

■ 产品配置

M-2RH无线麦克风

接收主机	1台
手持麦克风.....	2个
音频连接线.....	2条
电源适配器.....	1个
UHF天线	2支
BNC转接头	2个
BNC连接线	2条
AA 1.5V电池	4节
手提箱.....	1个
说明书.....	1份

M-2RP无线麦克风

接收主机	1台
腰包发射机.....	2个
领夹麦克风.....	2只
音频连接线.....	2条
电源适配器.....	1个
UHF天线	2支
BNC转接头	2个
BNC连接线	2条
AA 1.5V电池	4节
手提箱.....	1个
说明书.....	1份

M-2R系列 无线一拖二麦克风

■ 技术参数

接收机参数

- 频率范围:516-558MHz
- 最大频道数:1280
- 系统兼容性:支持8台叠机使用
- 频率响应:50Hz-16kHz(±3dB)
- 频率带宽:42MHz
- 总谐波失真:<0.5%
- 射频灵敏度:<-104dBm
- 音频输出电平:10dBu Max
- 工作距离:100m
- 信噪比:≥110dB(A)
- 产品尺寸:482*160*44mm
- 输出接口:一路Ø6.3混合输出,二路卡侬座平衡输出
- 电源规格:DC12V/18V-1A
- 产品重量:约2600g

腰包发射机参数

- 频率范围:516-558MHz
- 频率带宽:42MHz
- 最大偏频:±60kHz
- 增益调节范围:0/-10/-20/-30/-40 dB
- 射频功率:10mW/30mW/50mW
- 频率响应:50Hz-16kHz(±3dB)
- 显示方式:发光管LED
- 电池规格:2×1.5V AA 碱性
- 续用时间:>8小时
- 产品重量:约90g(不含电池)

手持发射机参数

- 频率范围:516-558MHz
- 频率带宽:42MHz
- 最大偏频:±60kHz
- 增益调节范围:0/-10/-20/-30/-40 dB
- 射频功率:10mW/30mW/50mW
- 频率响应:50Hz-16kHz(±3dB)
- 显示方式:发光管LED
- 电池规格:2×1.5V AA 碱性
- 续用时间:>8小时
- 产品重量:约350g(不含电池)

注:以上数据由得胜实验室测试得到,并拥有最终解释权!

M-2R系列 无线一拖二麦克风

■ 功能示意

M-2R接收机前面板

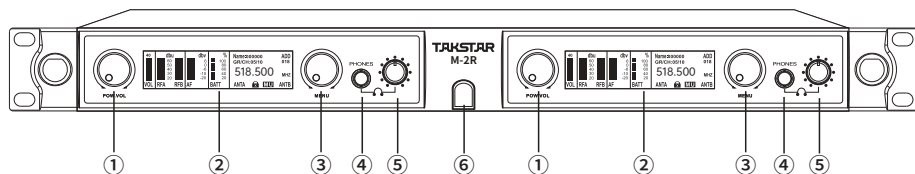

① 电源开关/音量调节/快速对频/退回主菜单

-长按2秒, 开机或关机。

-开机状态下, 左右旋转可调节音量增益大小。

-开机状态下, 点按可快速对频。

-开机状态下, 进入用户设置界面, 点按可退回主菜单。

② OLED显示屏

③ 系统菜单键

④ 监听耳机输出接口

⑤ 监听耳机输出音量调节旋钮

⑥ IR红外对频窗口

M-2R接收机背面板

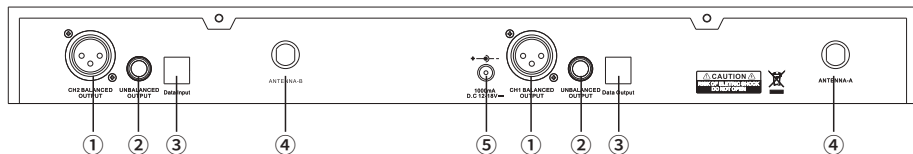

① XLR输出插座

② 1/4英寸输出插座

③ 数据插座

④ BNC天线插座

⑤ 电源插座

M-2R系列 无线一拖二麦克风

接收机显示屏功能

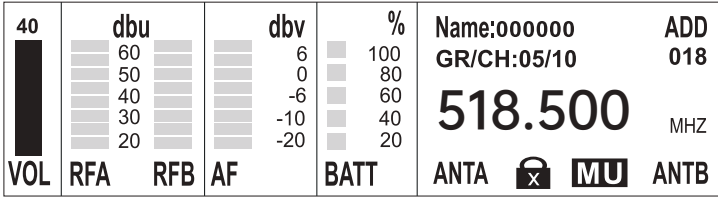

显示	功能
VOL	音量大小指示
RFA	A 路射频信号强度
RFB	B 路射频信号强度
AF	音频电平指示值
BATT	发射机电池显示量
Name	使用者名称
ADD	地址码
GR	频率组号
CH	频率组下的通道
ANTA	A 路射频信号指示灯
ANTB	B 路射频信号指示灯
	面板操作锁定
	发射机静音指示

M-2R系列 无线一拖二麦克风

M-2RH手持发射机

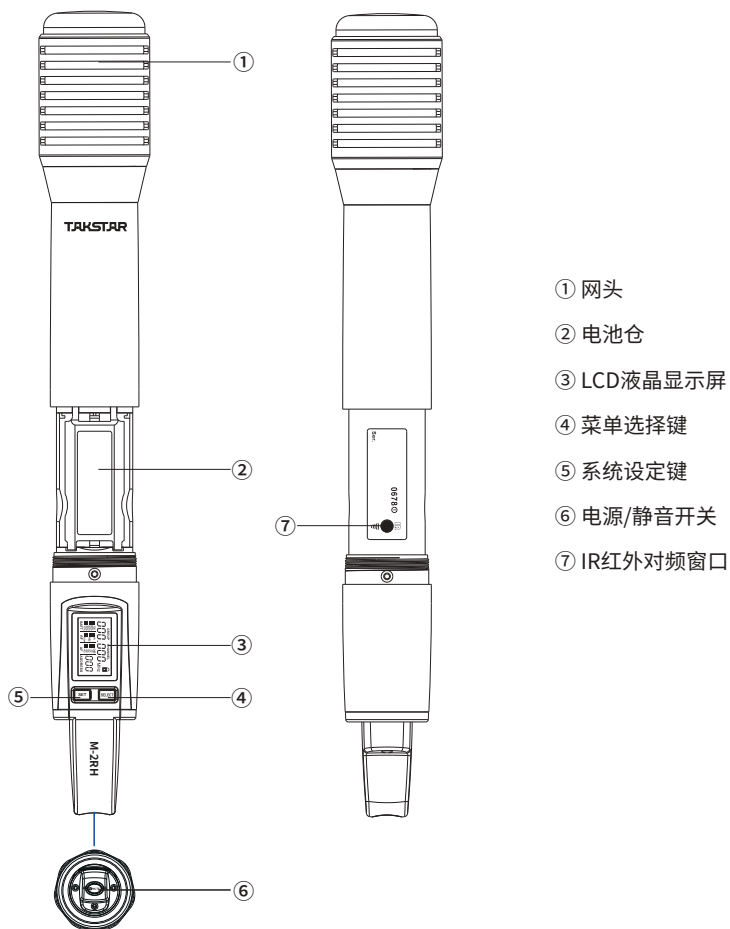

更换电池：

两节碱性电池的预期使用时间约为8小时。当接收机或发射机显示屏电量指示符号持续闪动时，请在15分钟内更换电池。

M-2R系列 无线一拖二麦克风

M-2RP腰包发射机

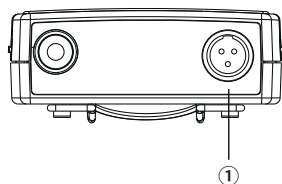
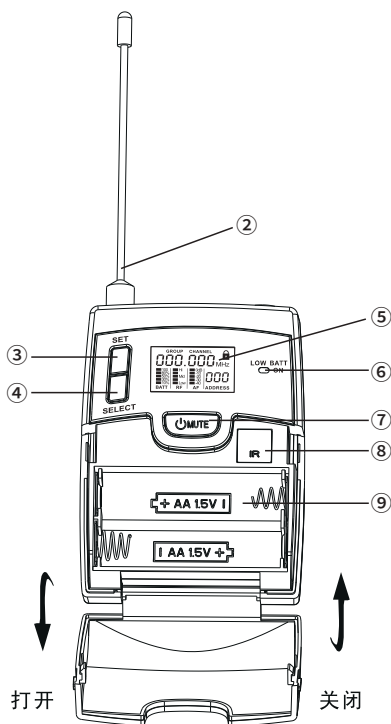

- ① 三插针话筒输入插座
- ② 天线
- ③ SET系统设定键
- ④ 菜单选择键
- ⑤ LCD液晶显示屏
- ⑥ 电源低压指示灯
- ⑦ 电源/静音开关
- ⑧ IR红外对频窗口
- ⑨ 电池仓

更换电池：

两节碱性电池的预期使用时间约为8小时。当接收机或发射机显示屏电量指示符号持续闪动时，请在15分钟内更换电池。

注：此时电源低压指示灯也会点亮。

腰包发射机的佩戴：

将发射机夹扣在皮带上①，也可将吉他带穿过发射机夹②。若要达到最佳效果，应将发射机往下推，直到皮带贴紧发射机夹的底座①。

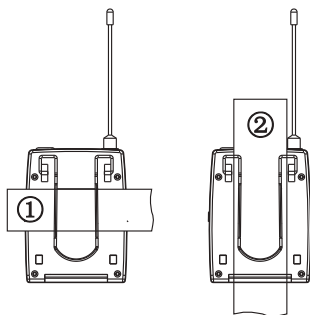

M-2R系列 无线一拖二麦克风

发射机显示屏功能

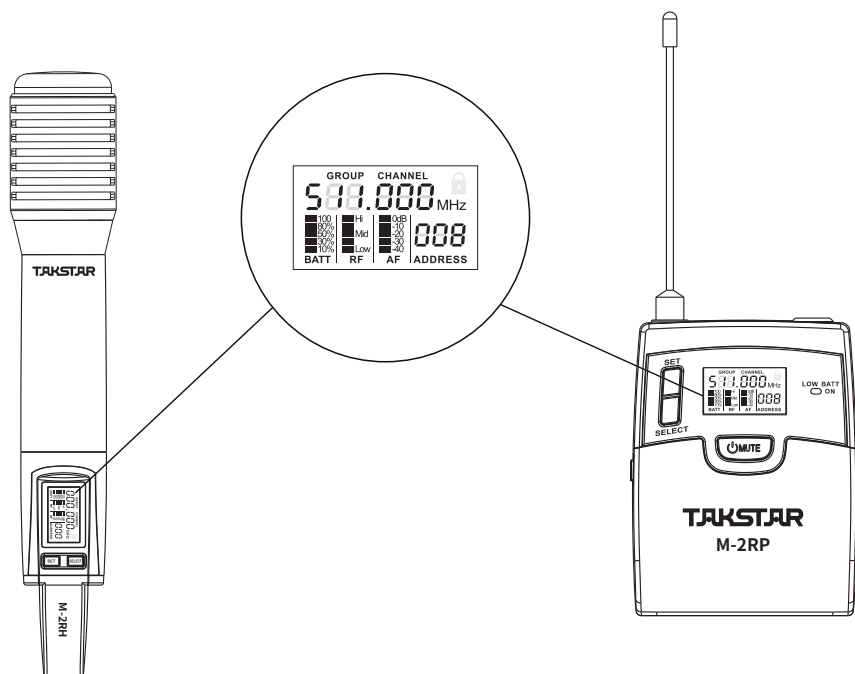

显示	功能
GROUP	当前使用的频率组
CHANNEL	当前使用频率组下的通道
BATT	电池电显指示
RF	发射功率选择
AF	音频衰减选择
ADDRESS	地址码

M-2R系列 无线一拖二麦克风

■ 使用说明

一、接收机使用说明

开/关机操作

开机:长按POW.VOL旋钮,屏幕显示亮起,设备开机并进入工作状态。

关机:长按POW.VOL旋钮,屏幕显示“OFF”标志,表示设备完成关机。

注:每次开关机操作将被记录,如在开机状态下断电,下次通电时将自动开机。

基本功能设置

点按MENU旋钮,进入系统设置功能界面,左右旋转旋钮选择功能设定。

1. 频率组设置

选择Group项并按下MENU旋钮进入组选择(界面如下图),旋转MENU旋钮选择1-20组或User,再按MENU旋钮保存设置,接收频率也随之变为该组对应的频道。

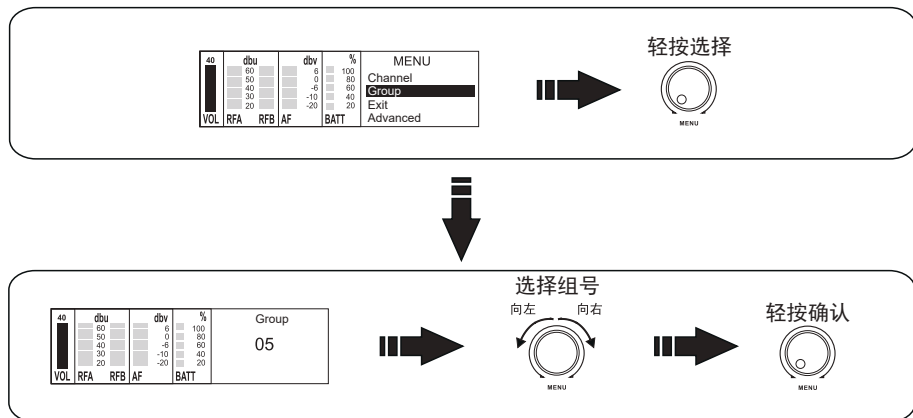

2. 频道设定

选择Channel项并按下MENU旋钮进入频道选择(界面如下图),旋转MENU旋钮选择相应频道,再按MENU旋钮保存设置。

M-2R系列 无线一拖二麦克风

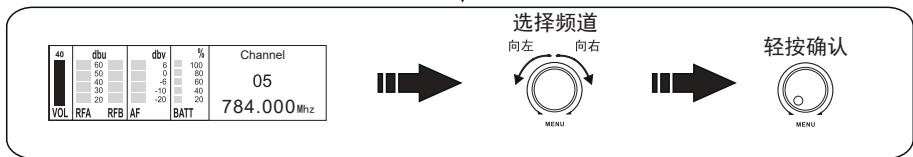
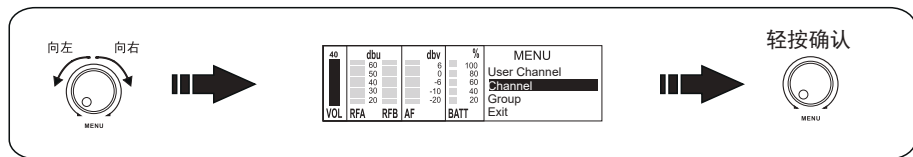

3. 用户频率设定

选择User Channel项并按下MENU旋钮进入用户频率选择(界面如下图), 旋转MENU旋钮选择频率后三位数, 每次步进为25KHz, 轻按MENU确认后, 再旋转MENU键选择频率前三位数, 每次步进为1MHz, 轻按MENU确认后, 频率设定完成。注: 系统共有1680个频率可选。

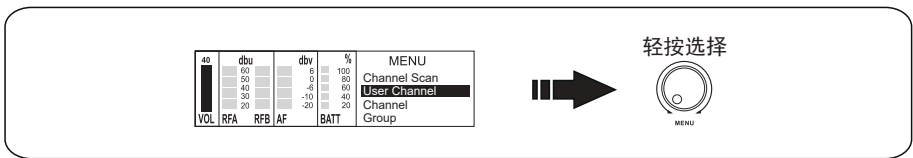

M-2R系列 无线一拖二麦克风

4. 频道扫描

选择Channel Scan项并按下MENU旋钮进入通道扫描选择(界面如下图),再次按下MENU旋钮启动扫描,系统将在目前所设定的频率组内搜索空闲频道并自动保存。

注:在搜索的过程中,如按下MENU旋钮将停止搜索。

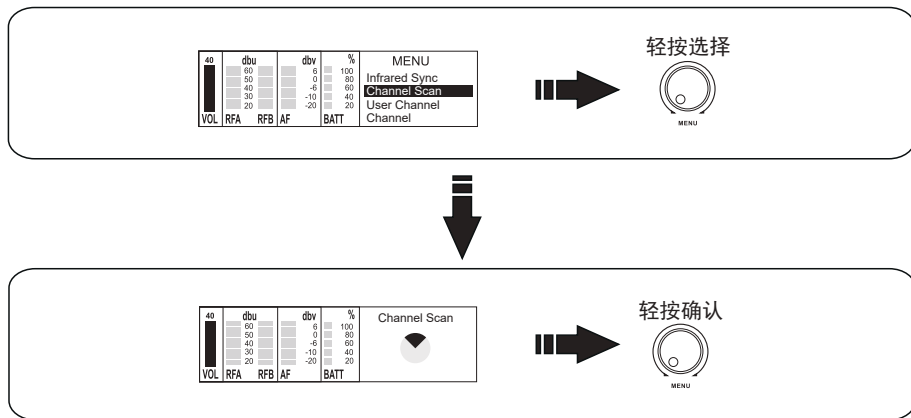

5. 锁定设置

选择Lock项并按下MENU旋钮进入锁定设置选择(界面如下图),顺时针旋转MENU为选择锁定,逆时针旋转MENU为解除锁定,再按MENU旋钮保存设置。

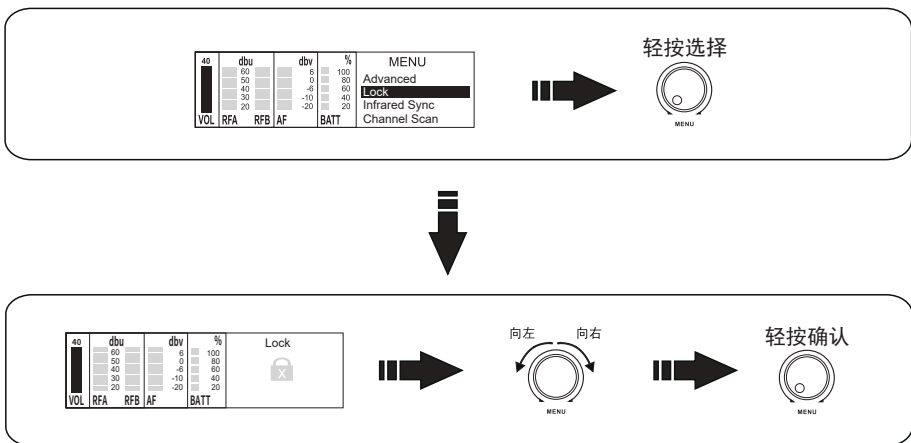

M-2R系列 无线一拖二麦克风

6. 对频操作

选择Infrared Sync项并按下MENU旋钮进入红外线数据同步选择(界面如下图),再次按下MENU旋钮启动红外线数据发送,将发射机红外对频窗口对准主机红外窗口(50CM内),发射机将自动同步接收机数据,自动对频完成。

快捷对频

主界面下轻按POW.VOL旋钮启动红外数据发送功能,将发射机红外对频窗口对准主机红外窗口(50CM内),发射机将自动同步接收机数据,自动对频完成。

注:红外线发送时间为25秒,之后将自动退回主界面。

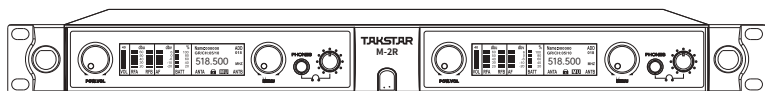
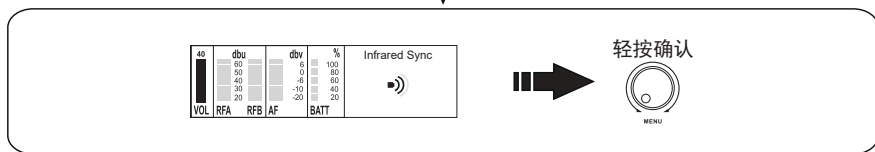
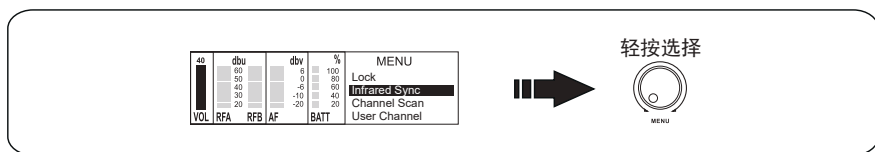

M-2RP 对频

M-2RH 对频

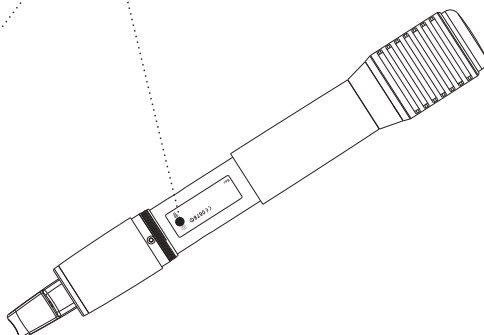
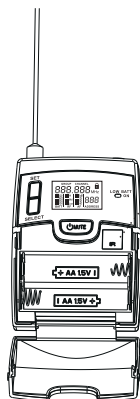

M-2R系列 无线一拖二麦克风

高级菜单设置

主界面下轻按MENU旋钮进为菜单, 选择Advanced选项, 再按MENU旋钮进入高级菜单设置界面。

1. 使用者名称设置

选择Name项并按下MENU旋钮进入用户名设置界面(如下图所示), 旋转MENU旋钮选取字符(0-9和A-Z), 按MENU确认所选字符, 依次选取6个字符后再按MENU键确认保存。

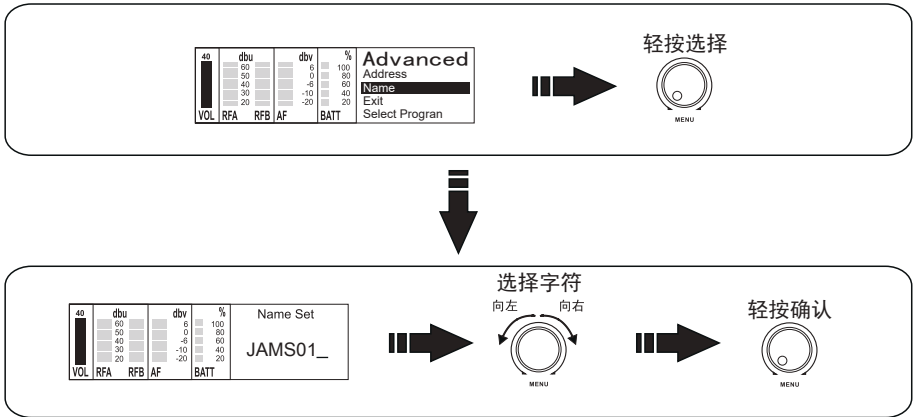

2. 地址码设置

选择Address项并按下MENU旋钮进入地址码设置界面(如下图所示), 旋转MENU旋钮编辑地址码(0-224), 再按MENU旋钮将设置保存。

注: 系统共有225个地址码可选, 多机使用时每个系统应选取不同的地址码。

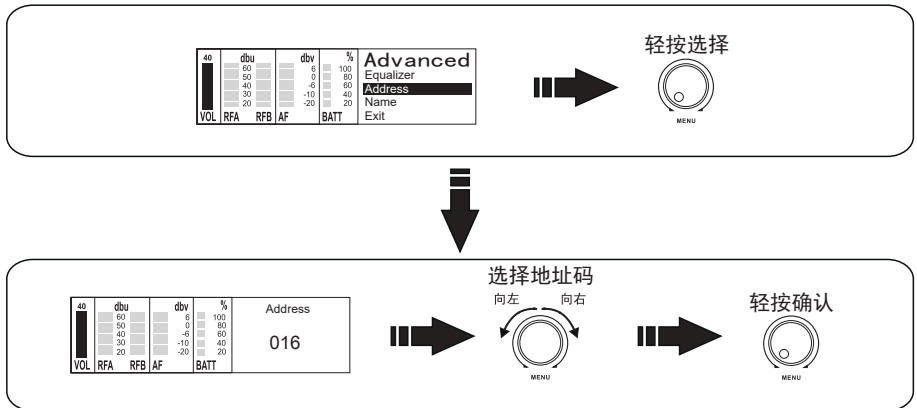

M-2R系列 无线一拖二麦克风

3. 均衡设置

选择Equalizer项并按下MENU旋钮进入均衡设置界面(如下图所示), 旋转MENU旋钮选取相应模式, 再按MENU确认保存。系统具有4种均衡模式, 分别为平直、低切、高通、低切+高通。

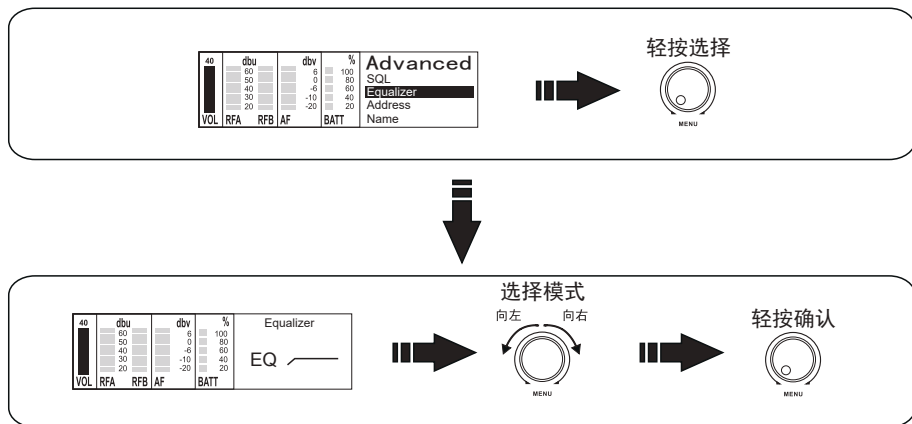

4. 静噪阈值设置

选择SQL项并按下MENU旋钮进入静噪阈值设置界面(如下图所示), 旋转MENU旋钮选取相应阈值, 再按MENU确认保存。

共高、中、低3种阈值选择, 建议远距离使用时设置静噪门为低阈值状态; 有干扰源时可选取中或高阈值状态, 以提高抗干扰能力, 但此时使用距离会变近。

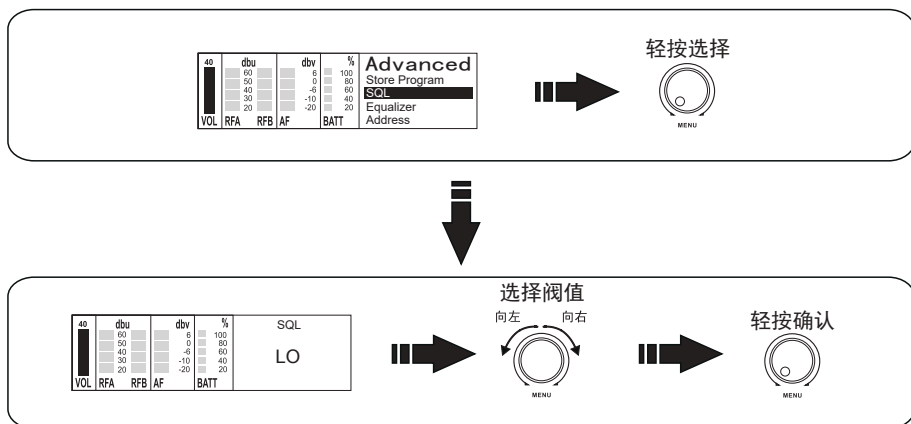

M-2R系列 无线一拖二麦克风

5. 储存设置程式

选择Store Program项并按下MENU旋钮进入储存程式设置界面(如下图所示), 旋转MENU旋钮选取储存地址码(0-9), 按MENU选择确认或退出。系统有10个地址码, 最多可储存10种设置状态。

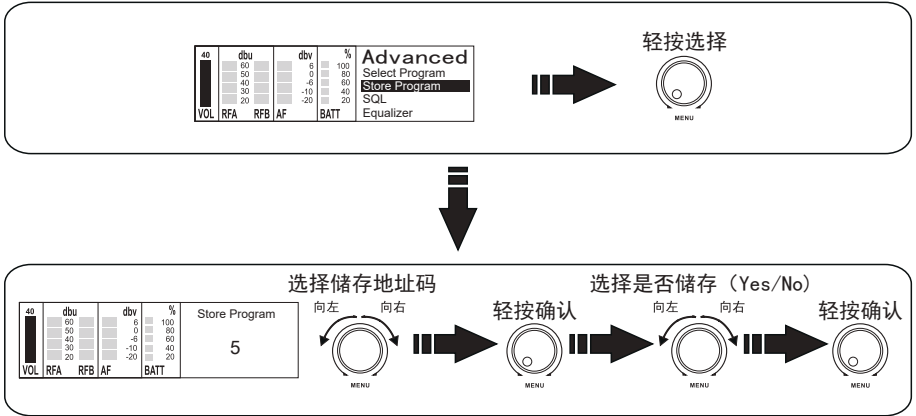

6. 选取储存程式

选择Select Program项并按下MENU旋钮进入选取储存程式界面(如下图所示), 旋转MENU旋钮选取储存程式(0-9), 按MENU选择确认。

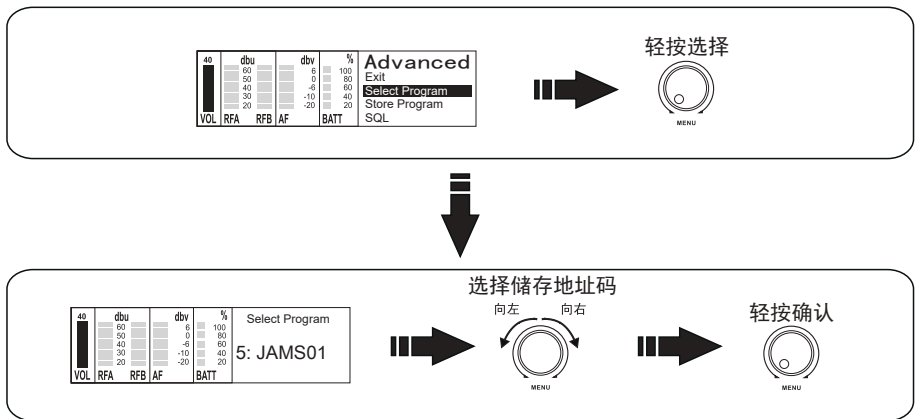

7. 退出选择

选择Exit项并按下MENU旋钮将退出高级设置菜单, 返回主菜单。

M-2R系列 无线一拖二麦克风

二、发射机使用说明

1. 开关机和静音控制

长按电源/静音开关2秒可开启或关闭发射机,点按电源/静音开关发射机静音(AF指示持续闪烁),再按一次解除静音(如下图所示)。

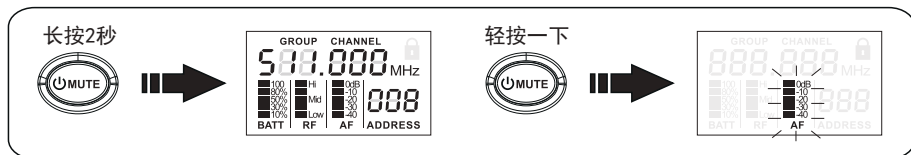

2. 组号/频道/话筒增益/发射功率/地址码/锁定设置

长按SELECT键2秒进入设置状态,点按SET键选择相应参数,再按SELECT键进入下一功能选项,设定完成后退出主界面(如下图所示)。

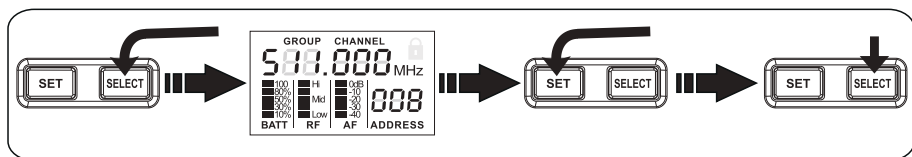

3. 锁定和解锁

长按SELECT键2秒进入设置状态,连按SELECT键至LOC字符闪烁,再按SET键锁定(此时显示🔒符号),再按SELECT键返回主界面(如下图所示)。

锁定状态下长按SELECT键至LOC字符闪烁,再按SET键即可解锁(此时🔒符号消失),再按SELECT键返回主界面。

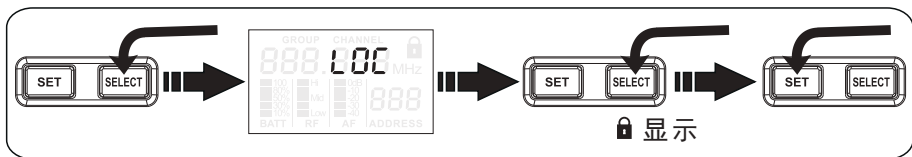

4. 查看工作频率

主界面下点按SET键或SELECT键,会显示目前发射机工作频率,5秒后自动返回主界面。

M-2R系列 无线一拖二麦克风

■ 故障排除

问题	显示状态	解决方法
没有声音或声音微弱	发射机无法开启	<ol style="list-style-type: none">1. 确认电池上的正负极标志与发射机的端接相匹配。2. 电池电压太低，更换电池。
	接收机无法开启	<ol style="list-style-type: none">1. 确认交流电源适配器的一头是否插入电源插座，另一头是否插入接收机后板上的直流输入插孔。2. 确认交流电源适配器是否正常，并确认供电电压是否正常。
	接收机 RF 讯号灯点亮	<ol style="list-style-type: none">1. 调高接收机音量控制。2. 调高发射机上增益开关设置。3. 检查接收机与放大器或混音器间的电缆连接。
	接收机 RF 讯号灯不亮， 发射机打开时指示灯闪动	<ol style="list-style-type: none">1. 将接收机从金属物体旁边移开。2. 检查发射机和接收机之间是否有障碍物。3. 将发射机移近接收机。4. 检查接收机和发射机是否使用同一频率。
	发射机低压指示灯点亮	更换发射机电池。
失真或多余的杂音	接收机 RF 讯号灯点亮	<ol style="list-style-type: none">1. 移除附近的射频干扰源（如CD机、电脑、数字装置、耳塞监听系统等）。2. 将接收机和发射机改至不同的频率。3. 降低发射机增益。4. 更换发射机电池。5. 如果使用多系统，可增加各系统间的频率间隔。
失真电平逐渐增加	发射机低压指示灯点亮	更换发射机电池。
声音电平与电吉他或话筒不同，或是使用不同的吉他时声音电平不同		根据需要调整发射机增益和接收机音量。

M-2R系列 无线一拖二麦克风

■ 安全警示

为避免电击、高温、着火、辐射、爆炸、机械危险以及使用不当等可能造成的人身伤害或财产损失，使用本产品前，请仔细阅读并遵守以下事项：

1. 使用产品时请确认所连设备与本产品是否匹配以及合理调整音量大小，不要在超过产品功率及大音量下长时间使用，以免造成产品异常；
2. 使用中若发现有异常（如冒烟、异味等），请立即关闭电源开关并拔掉电源插头，然后将产品送售后服务网点检修；
3. 若产品需要使用可拆装电池时，严禁使用外壳绝缘材料破损的电池，请不要为非充电电池充电；
4. 废弃电池需放入指定的分类垃圾桶，不可作为儿童玩具或直接丢弃，以免造成安全隐患或影响环境；
5. 本产品及配件都应放置在室内干燥通风处，勿长期存放在潮湿、灰尘多的环境，使用中避免靠近裸露火源、碰到液体物质、雨淋、产品进水、过度碰撞、抛掷、振动本机及覆盖通风孔，以免损坏其功能；
6. 若产品需要固定于墙壁或天花板上时，请确保固定到位，防止因固定强度不足导致产品发生跌落危险；
7. 使用该产品时需遵守相关安全规定，法律法规明确禁止使用场合请勿使用本机，以免导致意外事故；
8. 请不要自行拆机改装或维修，以防止出现人身伤害，如有问题或服务需求请联系当地售后服务网点跟进处理。

■ 关于图标含义解释



此符号表示，根据WEEE指令(2012/19/EU)和国家法律，由于这种类型的废弃物会有潜在的有害物质，可能对环境 and 人类健康产生负面影响，所以本产品不应与您的家庭垃圾一起处置，

应将本产品交由授权的电气和电子设备（WEEE）回收站回收。同时，您在正确处理本产品的同时将有助于自然资源的有效利用。如需了解更多有关您可以在何处放置废物回收设备的信息，请联系您当地的城市办事处、废物管理局或家庭废物处理服务部门。

■ 关于本说明书

本说明书中内容符合截止印刷之日的技术规格。由于得胜公司会不断改进产品，本说明书可能不符合您的特定产品的技术规格。要获取最新版说明书，请访问得胜官网，然后下载说明书文件。技术规格、设备或另售的附件在各个地区可能有所不同，如有问题请与当地得胜销售网点确认。如需更多支持和深层产品信息，请浏览得胜官方网站：<https://www.takstar.com>

版权所有 ©2024 得胜。得胜、TAKSTAR及其各自标志是广东得胜电子有限公司在中国和/或其他国家/地区的注册商标或商标。所有其它商标均是其各自所有者的财产。

M-2R Series Dual-Channel Wireless Microphone System

■ Preface

Dear Customer,

Thank you for purchasing our product. Read this manual thoroughly to use the product properly.

If you have any questions or suggestions, please contact our local sales service.

■ Features

- True diversity wireless digital pilot tone for enhanced signal and interference resistance.
- Automatic frequency tracking for stable output and improved reliability.
- 1280 frequency points in 42MHz bandwidth, supporting over 16 simultaneous channels.
- 225 selectable address codes; 20 user frequency groups and 10 channel configurations.
- Automatic idle channel selection and PC connection for scanning and assignment.
- Quick automatic scanning to identify interference-free channels.
- PC interface for detailed monitoring and control.
- 4 built-in EQ settings for customizable audio.
- 3 noise gate thresholds for clearer communication and reduced noise.
- Saves and retrieves up to 10 preset configurations.
- Independent monitoring output for real-time audio checks.
- 3 power settings on the transmitter for distance adaptability.
- 5-segment battery and audio level displays on receiver and transmitter.
- User name setting with six-character (0-9 or A-Z) options.
- Dual rotary switch with drop-down menu for easy operation.
- OLED display on receiver; LCD display on transmitter for clear status overview.

■ Applications

For high-demand projects such as concerts, public broadcasting, and performance venues.

M-2R Series Dual-Channel Wireless Microphone System

■ Package Contents

M-2RH Wireless Microphone

- 1 × Receiver Unit
- 2 × Handheld Microphone
- 2 × Audio Connection Cable
- 1 × Power Adapter
- 2 × UHF Antenna
- 2 × BNC Adapter
- 2 × BNC Cable
- 4 × AA 1.5V Battery
- 1 × Carrying Case
- 1 × User Manual

M-2RP Wireless Microphone

- 1 × Receiver Unit
- 2 × Bodypack Transmitter
- 2 × Lavalier Microphone
- 2 × Audio Connection Cable
- 1 × Power Adapter
- 2 × UHF Antenna
- 2 × BNC Adapter
- 2 × BNC Cables
- 4 × AA 1.5V Battery
- 1 × Carrying Case
- 1 × User Manual

M-2R Series Dual-Channel Wireless Microphone System

■ Specifications

Receiver

- Frequency Range: 516-558MHz
- Maximum Channels: 1280
- System Compatibility: Supports 8 devices operating simultaneously
- Frequency Response: 50Hz-16kHz ($\pm 3\text{dB}$)
- Frequency Bandwidth: 42MHz
- Total Harmonic Distortion: $<0.5\%$
- RF Sensitivity: $< -104\text{dBm}$
- Audio Output Level: 10dBu Max
- Operating Distance: 100m
- Signal-to-Noise Ratio: $\geq 110\text{dB (A)}$
- Product Dimensions: 482*160*44mm
- Output Interfaces: One $\varnothing 6.3$ mixed output, two balanced XLR outputs
- Power Requirements: DC12V/18V-1A
- Product Weight: Approx. 2600g

Handheld Transmitter

- Frequency Range: 516-558MHz
- Frequency Bandwidth: 42MHz
- Maximum Deviation: $\pm 60\text{kHz}$
- Gain Adjustment Range: 0/-10/-20/-30/-40 dB
- RF Power: 10mW/30mW/50mW
- Frequency Response: 50Hz-16kHz ($\pm 3\text{dB}$)
- Display Type: LED
- Battery Spec: 2 \times 1.5V AA alkaline
- Operating Time: >8 hours
- Product Weight: Approx. 350g (excl. batteries)

Bodypack Transmitter

- Frequency Range: 516-558MHz
- Frequency Bandwidth: 42MHz
- Maximum Deviation: $\pm 60\text{kHz}$
- Gain Adjustment Range: 0/-10/-20/-30/-40 dB
- RF Power: 10mW/30mW/50mW
- Frequency Response: 50Hz-16kHz ($\pm 3\text{dB}$)
- Display Type: LED
- Battery Spec: 2 \times 1.5V AA alkaline
- Operating Time: >8 hours
- Product Weight: Approx. 90g (excl. batteries)

Note: The above data are measured by Takstar laboratory which has the final interpretation right!

M-2R Series Dual-Channel Wireless Microphone System

■ Function Descriptions

M-2R Receiver Front Panel

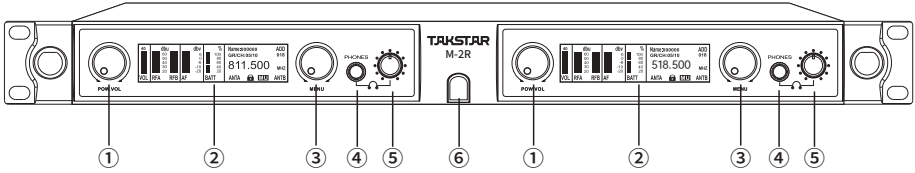

1. Power/Volume/Sync/Back Button

- Long press for 2s to power on/off.
- When powered on, rotate to adjust volume gain.
- When powered on, tap to quickly sync frequency.
- When powered on and in user settings, tap to return to main menu.

2. OLED Display Screen

3. System Menu Button

4. Headphone Output Jack

5. Headphone Volume Control Knob

6. IR Sync Window

M-2R Receiver Rear Panel

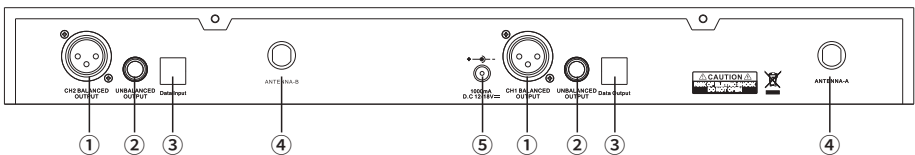

1. XLR Output Jack

2. 1/4-inch Output Jack

3. Data Port



4. BNC Antenna Jack

5. Power Jack

M-2R Series Dual-Channel Wireless Microphone System

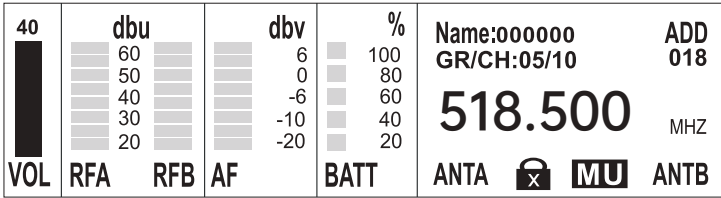
Receiver Display Functions



Display	Function
VOL	Volume level indication
RFA	RF signal strength for Channel A
RFB	RF signal strength for Channel B
AF	Audio level indication
BATT	Transmitter battery level
Name	User name
ADD	Address code
GR	Frequency group number
CH	Channel under frequency group
ANTA	RF signal indicator for Channel A
ANTB	RF signal indicator for Channel B
	Panel operation lock
	Transmitter mute indicator

M-2R Series Dual-Channel Wireless Microphone System

M-2RH Handheld Transmitter

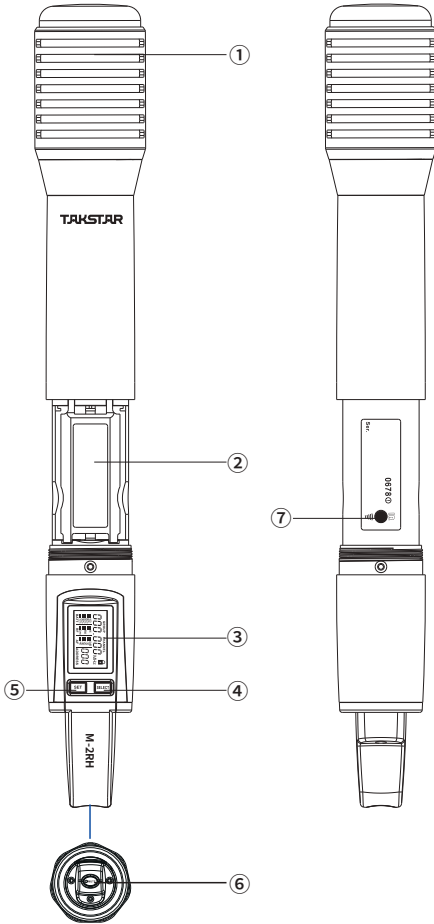

1. Microphone Head
2. Battery Compartment
3. LCD Display Screen
4. Menu Selection Button
5. System Setting Button
6. Power/Mute Switch
7. IR Sync Window

Battery Replacement:

Expected battery life for two alkaline batteries is about 8 hours. Replace batteries within 15 minutes when the battery indicator on the receiver or transmitter flashes.

M-2R Series Dual-Channel Wireless Microphone System

M-2RP Bodypack Transmitter

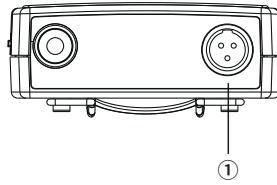
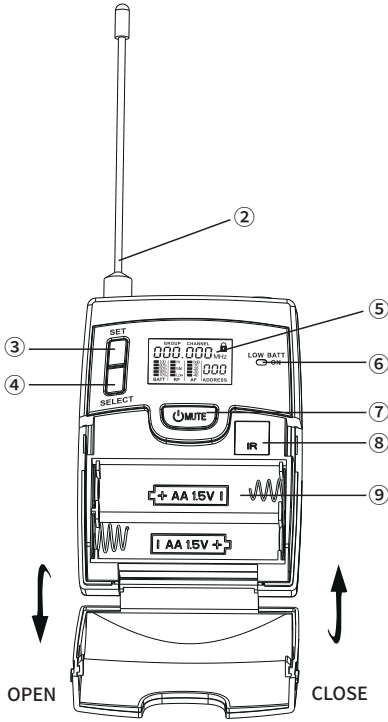

1. Three-pin Mic Input Jack
2. Antenna
3. SET System Setting Button
4. Menu Selection Button
5. LCD Display Screen
6. Low Power Indicator
7. Power/Mute Switch
8. IR Sync Window
9. Battery Compartment

Battery Replacement:

Expected battery life for two alkaline batteries is about 8 hours. Replace batteries within 15 minutes when the battery indicator on the receiver or transmitter flashes. Note: Low power indicator will also illuminate.

Bodypack Transmitter Wearing:

Clip the transmitter onto a belt or thread a guitar strap through the clip. For optimal performance, push the transmitter down until the belt is snug against the clip base.

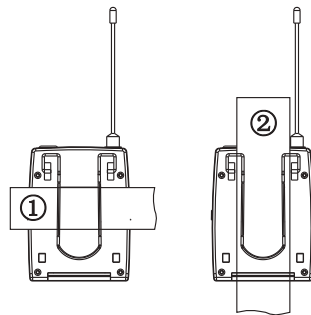

M-2R Series Dual-Channel Wireless Microphone System

Transmitter Display Functions

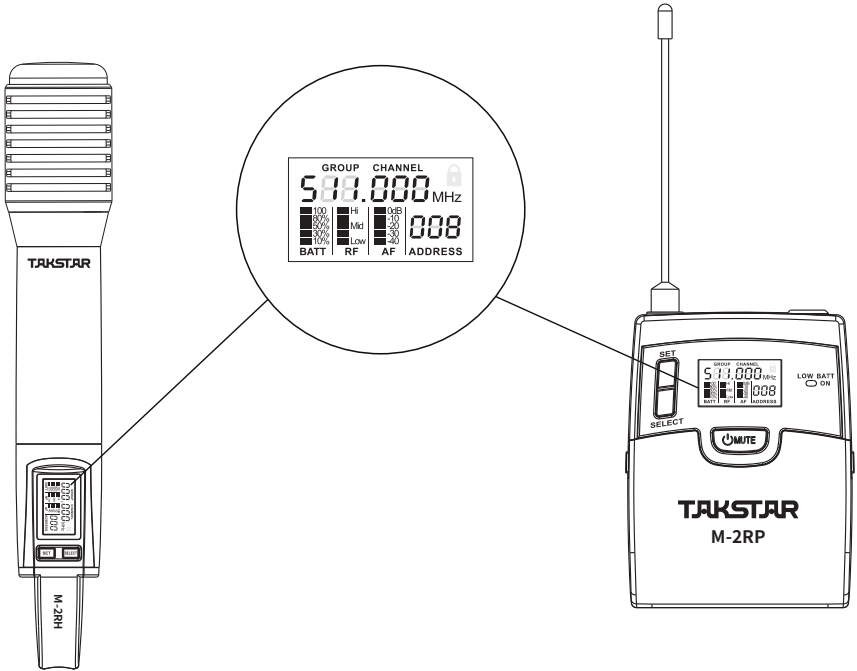

Display	Function
GROUP	Current frequency group in use.
CHANNEL	Current channel under the frequency group.
BATT	Battery level indication.
RF	Transmit power selection.
AF	Audio attenuation selection.
ADDRESS	Address code display.

M-2R Series Dual-Channel Wireless Microphone System

■ Operating Instructions

I. Receiver User Guide

Power On/Off Operations

- Power On: Long press the POW.VOL knob; the screen will light up, indicating the device is powered on and in operation.
- Power Off: Long press the POW.VOL knob; the screen will display "OFF," indicating the device has shut down.

Note: Each power on/off action is recorded. If power is lost while on, the device will automatically power on when power is restored.

Basic Function Settings

Tap the MENU knob to enter the system settings interface. Rotate the knob left or right to select settings.

1. Frequency Group Setting

Select "Group" and press the MENU knob to enter group selection (see interface below). Rotate the MENU knob to choose groups 1-20 or User, then press the MENU knob to save the setting. The receiving frequency will change to the corresponding channel of the selected group.

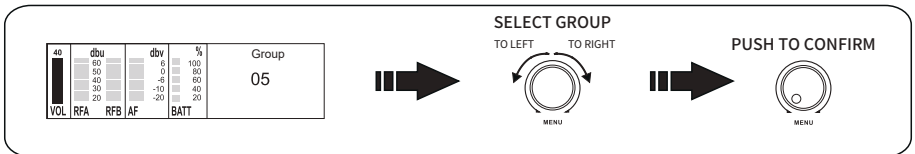
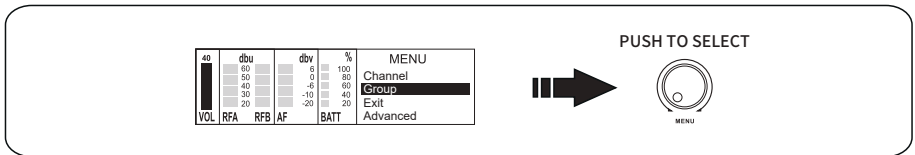

M-2R Series Dual-Channel Wireless Microphone System

2. Channel Setting

Select "Channel" and press the MENU knob to enter channel selection (see interface below). Rotate the MENU knob to choose the desired channel, then press the MENU knob to save the setting.

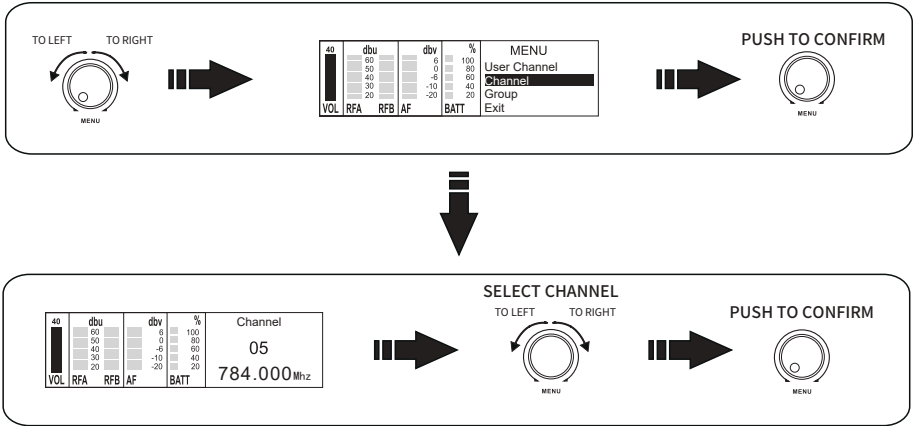

M-2R Series Dual-Channel Wireless Microphone System

3. User Frequency Setting

Select "User Channel" and press the MENU knob to enter user frequency selection (see interface below). Rotate the MENU knob to select the last three digits of the frequency in 25KHz steps, press MENU to confirm, then rotate the MENU knob to select the first three digits in 1MHz steps, press MENU to confirm. Frequency setting is now complete. Note: The system offers 1680 selectable frequencies.

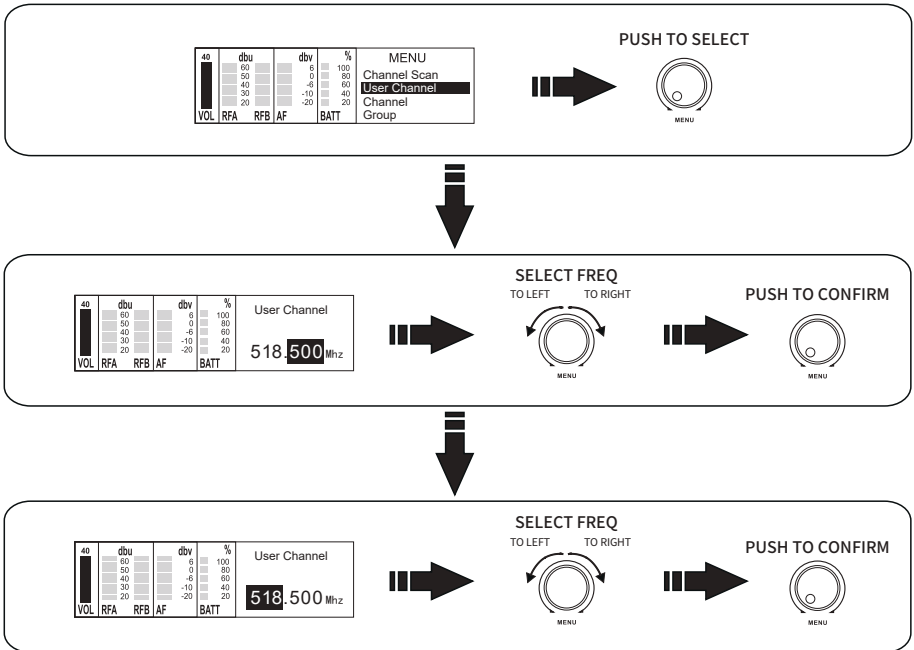

M-2R Series Dual-Channel Wireless Microphone System

4. Channel Scan

Select "Channel Scan" and press the MENU knob to enter channel scanning (see interface below). Press the MENU knob again to start the scan. The system will search for free channels within the current frequency group and automatically save them. **Note:** Pressing the MENU knob during the search will stop the scanning process.

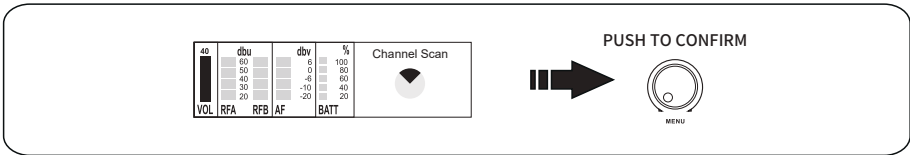
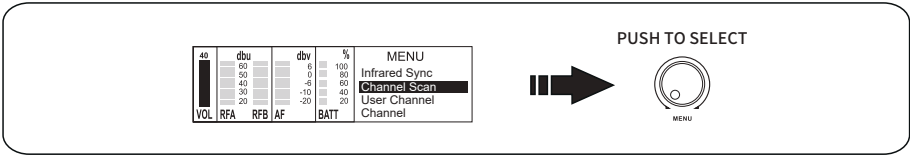

5. Lock Settings

Select "Lock" and press the MENU knob to enter lock settings (see interface below). Rotate the MENU knob clockwise to select lock, counterclockwise to unlock, and press the MENU knob to save the setting.

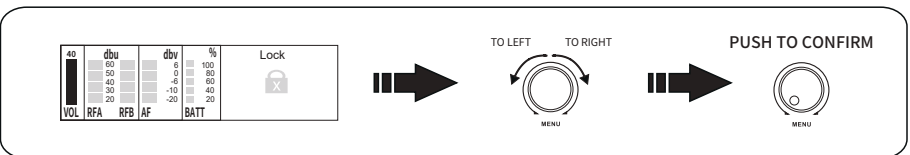
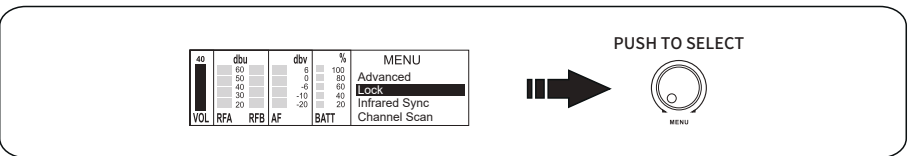

M-2R Series Dual-Channel Wireless Microphone System

Advanced Menu Settings

From the main interface, lightly press the MENU knob to access the menu, select the "Advanced" option, and press the MENU knob to enter the advanced menu settings.

1. User Name Setting

Select "Name" and press the MENU knob to enter the user name setting interface (see below). Rotate the MENU knob to select characters (0-9 and A-Z), press MENU to confirm each selected character, and choose six characters before pressing the MENU key to save.

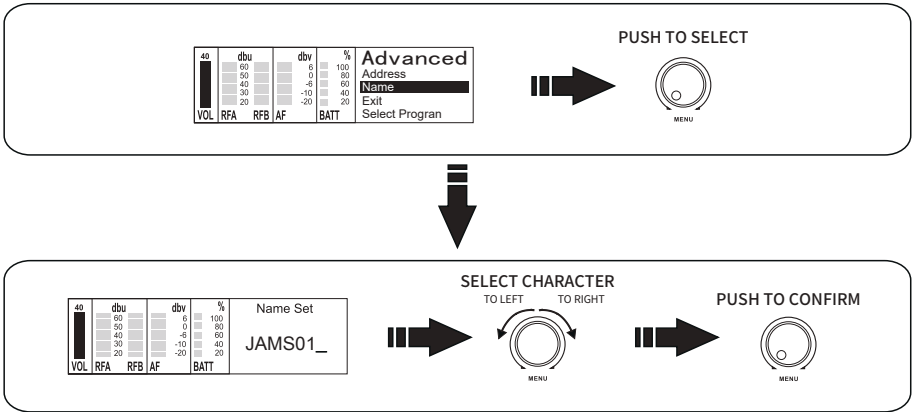

2. Address Code Setting

Select "Address" and press the MENU knob to enter the address code setting interface (see below). Rotate the MENU knob to edit the address code (0-224), then press the MENU knob to save the setting. **Note:** There are 225 address codes available; each system must have a unique address code when using multiple units.

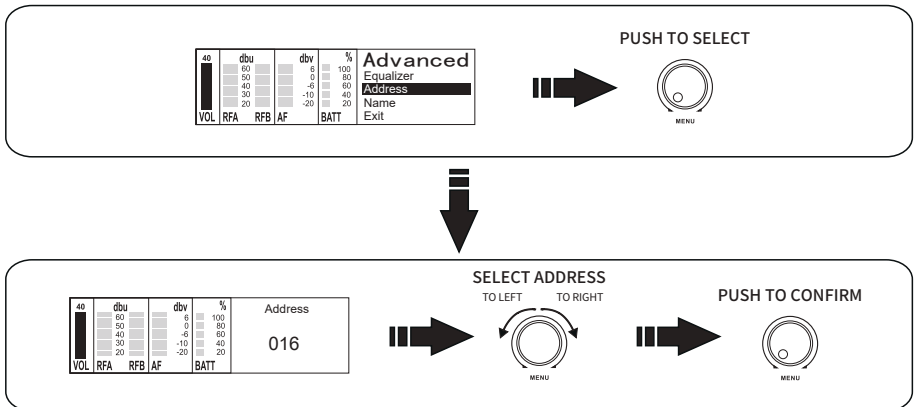

M-2R Series Dual-Channel Wireless Microphone System

3. Equalizer Setting

Select "Equalizer" and press the MENU knob to enter the equalizer setting interface (see below). Rotate the MENU knob to select the desired mode, then press MENU to confirm and save. The system features four equalizer modes: Flat, Low Cut, High Pass, and Low Cut + High Pass.

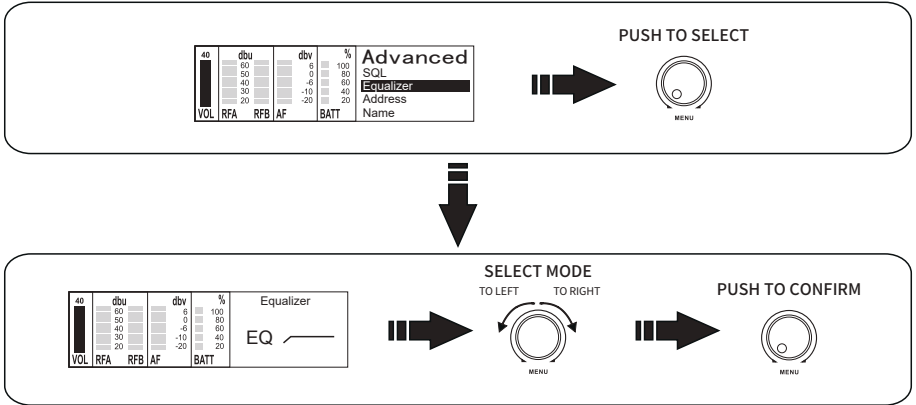

4. Noise Gate Threshold Setting

Select "SQL" and press the MENU knob to enter the noise gate threshold setting interface (see below). Rotate the MENU knob to choose the desired threshold, then press the MENU knob to confirm and save. There are three threshold options: High, Medium, and Low. For long-distance use, set the noise gate to low; for environments with interference, select medium or high to enhance resistance, but this will reduce operating distance.

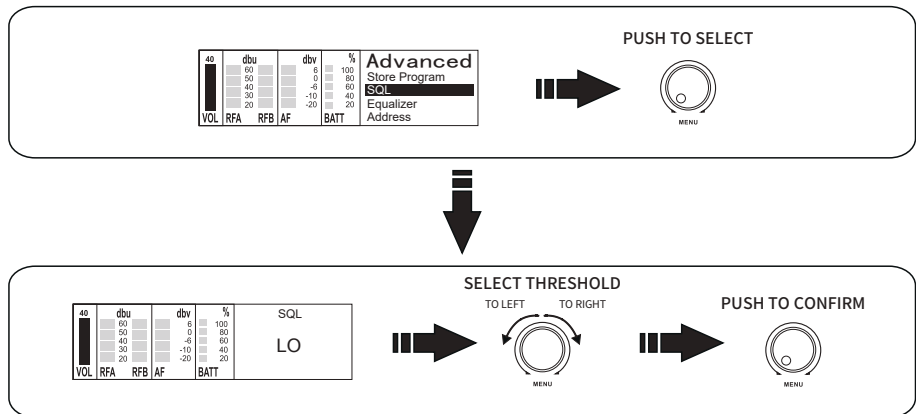

M-2R Series Dual-Channel Wireless Microphone System

5. Store Settings Program

Select "Store Program" and press the MENU knob to enter the store program setting interface (see below). Rotate the MENU knob to select a storage address (0-9), press MENU to confirm or exit. The system can store up to 10 settings.

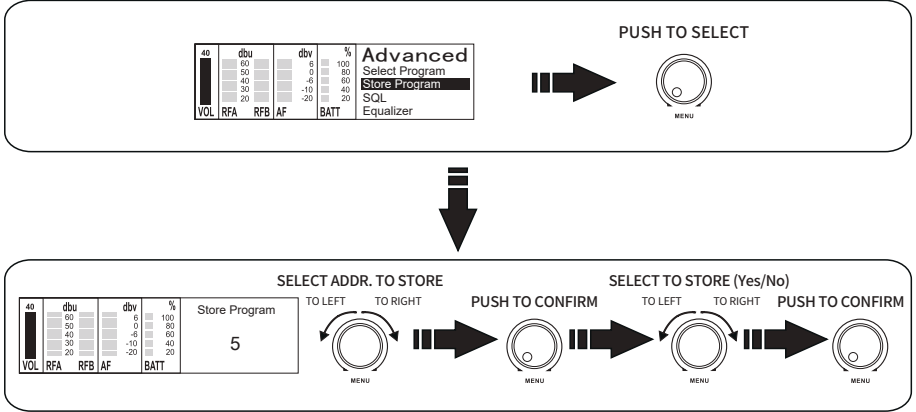

6. Select Stored Program

Select "Select Program" and press the MENU knob to enter the stored program selection interface (see below). Rotate the MENU knob to choose a stored program (0-9) and press the MENU knob to confirm.

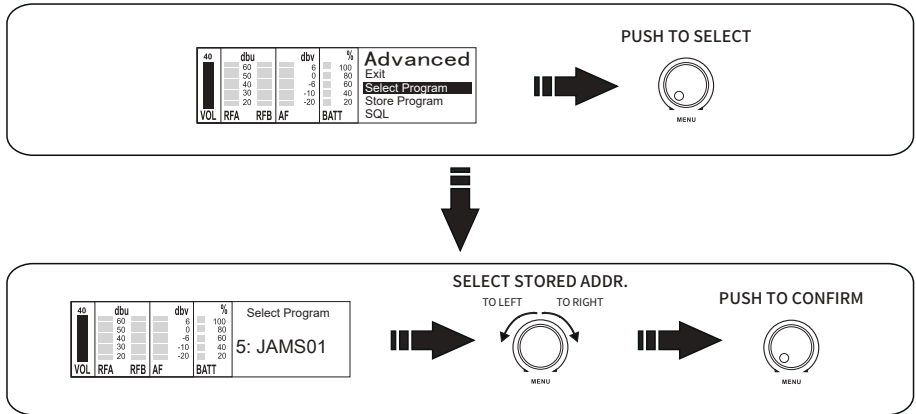

7. Exit Selection

Select "Exit" and press the MENU knob to exit the advanced settings menu and return to the main menu.

M-2R Series Dual-Channel Wireless Microphone System

II. Transmitter User Instructions

1. Power On/Off and Mute Control

Long press the power/mute switch for 2 seconds to turn the transmitter on or off. Tap the power/mute switch to mute the transmitter (AF indicator flashes continuously); tap again to unmute (see below).

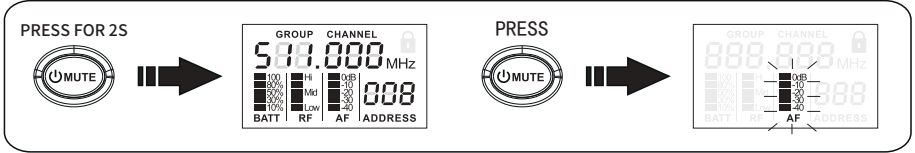

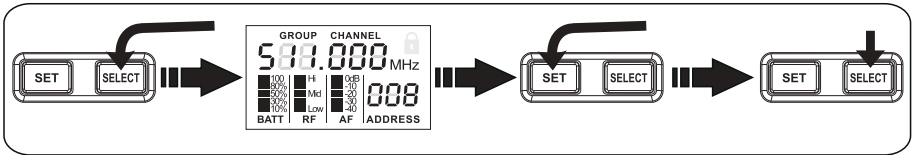

2. Group Number/Channel/Mic Gain/Transmit Power/Address Code/Lock Settings

Long press the SELECT button for 2 seconds to enter setup mode. Tap the SET button to select the desired parameter, then press the SELECT button to proceed to the next option. Exit to the main interface once settings are complete (see below).



3. Lock and Unlock

Long press the SELECT button for 2 seconds to enter setup mode. Press the SELECT button until the "LOC" character flashes, then press the SET button to lock (display shows the  symbol). Press SELECT to return to the main interface (see below). To unlock, long press the SELECT button until "LOC" flashes, then press the SET button ( symbol disappears), and press SELECT to return to the main interface.

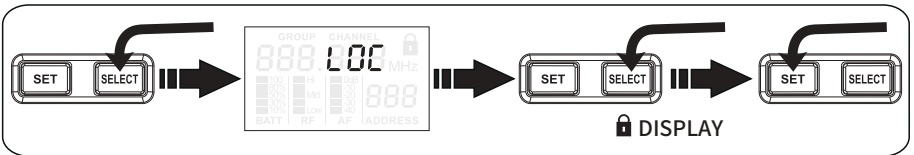

4. View Operating Frequency

From the main interface, tap the SET or SELECT button to display the current operating frequency of the transmitter; it will automatically return to the main interface after 5 seconds.

M-2R Series Dual-Channel Wireless Microphone System

■ Troubleshooting

Issue	Shown Status	Solution
No sound or weak sound	Transmitter won't power on	<ol style="list-style-type: none"> 1. Ensure the battery polarity matches the transmitter's terminals. 2. Replace the battery if the voltage is too low.
	Receiver won't power on	<ol style="list-style-type: none"> 1. Confirm that one end of the AC adapter is plugged into the power outlet and the other into the DC input on the receiver's rear panel. 2. Check if the AC adapter is functioning and that the supply voltage is normal.
	Receiver RF signal light is on	<ol style="list-style-type: none"> 1. Increase the receiver volume. 2. Raise the gain switch setting on the transmitter. 3. Check the cable connection between the receiver and amplifier or mixer.
	Receiver RF signal light is off, transmitter indicator flashes when powered on	<ol style="list-style-type: none"> 1. Move the receiver away from metal objects. 2. Check for obstacles between the transmitter and receiver. 3. Bring the transmitter closer to the receiver. 4. Ensure both transmitter and receiver are set to the same frequency.
	Transmitter low voltage indicator is on	Replace the transmitter battery.
Distortion or excessive noise	Receiver RF signal light is on	<ol style="list-style-type: none"> 1. Remove nearby RF interference sources (e.g., CD players, computers, digital devices, in-ear monitoring systems). 2. Set the receiver and transmitter to different frequency. 3. Lower the transmitter gain. 4. Replace the transmitter battery. 5. If using multiple systems, increase the frequency spacing between each system.
Distortion level gradually increases	Transmitter low voltage indicator is on	Replace the transmitter battery.
Sound level differs with electric guitar or mic, or varies with different guitars		Adjust the transmitter gain and receiver volume as needed.

M-2R Series Dual-Channel Wireless Microphone System

■ Safety Instructions

To avoid electric shock, overheat, fire, radiation, explosion, mechanical risk and injury or property loss due to improper use, please read and observe the following items before use:

1. Please check if the power of the connected equipment matches with that of this product before operation. Adjust the volume to proper level during operation. Do not operate at over-power or high-volume level for extended time to avoid product malfunction.
2. If there is any abnormality during use (e.g., smoke, strange odor), please kill the power switch and unplug from power source, then send the product to the local after-sales service for repair.
3. For products that require removable batteries, never use damaged batteries with broken insulation materials. Do not attempt to charge non-rechargeable batteries.
4. Dispose of used batteries in designated recycling bins. Do not use them as toys or dispose of them directly, as it may pose safety hazards or harm the environment.
5. Keep this product and its accessories in a dry and ventilated area. Do not store in a humid or dusty area for extended time. Keep away from fire, rain, liquid intrusion, bumping, throwing, vibrating, or from blocking any ventilation openings, to prevent malfunction.
6. The product must, when installed on walls or ceilings, be fixed firmly in place at adequate strength to prevent from falling.
7. Please abide by safety rules during operation. Do not use the product in places prohibited by laws or regulations to avoid accident.
8. Do not disassemble or repair the product by yourself to avoid personal injury. If you have question or need service, please contact our local after-sales service.

■ Label Meanings



This symbol indicates that this product should not be disposed of with your household waste, according to the WEEE directive (2012/19/EU) and your national law. This product should be handed over to an authorized collection site for recycling waste electrical and electronic equipment (WEEE). Improper handling of this type of waste could have a possible negative impact on the environment and human health due to potentially hazardous substances that are generally associated with WEEE.

M-2R Series Dual-Channel Wireless Microphone System

At the same time, your cooperation in the correct disposal of this product will contribute to the effective usage of natural resources. For more information about where you can drop off your waste equipment for recycling, please contact your local city office, waste authority, or your household waste disposal service.

■ About This Manual

This manual contains up-to-date technical specifications as of printing. However, specifications contained herein may not conform to your particular product since Takstar is constantly improving its products. Also, specifications, devices or accessories available may vary from region to region. If you have any questions, please contact our local sales outlet. For the latest version/more information, please visit our website: <https://www.takstar.com/>

Copyright ©2024 TAKSTAR. TAKSTAR, 得胜 and their respective logos are registered trademarks or trademarks of Guangdong Takstar Electronic Co., Ltd. in the PRC, and/or other countries. All other trademarks are the property of their respective owners.

注意事项：

1. 本单为保修凭证，请用户妥善保管，如有遗失，恕不保修或退换。
2. 保修期限制：购买之日起十二个月内。
3. 除了不可抗力事件损坏外，由本公司负责，免费维修。
4. 如属保管不善或使用不当造成的损坏，维修点将酌情收费。
5. 擅自拆卸维修者，不予保修。
6. 以上保修条款仅限于中国市场适用（不含港澳台地区）。

产品服务保证书

姓名：_____ 电话：_____ 地址：_____

商品：_____ 型号：_____ 购买日期：_____ 年 ___ 月 ___ 日

维修记录栏（由维修员填写）	维修员签名	日期

◆广东得胜电子有限公司 ◆电话：400-6828-333 ◆地址：广东省惠州市博罗县龙溪街道富康一路2号



扫一扫，了解更多产品
Scan for more
product information

广东省电声工程技术研究开发中心 广东得胜电子有限公司制造

地址：广东省惠州市博罗县龙溪街道富康一路2号
服务热线：400 6828 333 传真：0752 6383950
邮箱：xs@takstar.com
网址：www.takstar.com

Guangdong Takstar Electronic Co., Ltd.
Address: No. 2 Fu Kang Yi Rd., Longxi Boluo
Huizhou, Guangdong 516121 China
Tel: 86 752 6383644 Fax: 86 752 6383952
Email: sales@takstar.com
Website: www.takstar.com