

TAKSTAR® 得胜



MS830/MS831/MS832

有线会议麦克风

Wired Conference Microphone

使用手册 | User Manual

■ 前言

尊敬的用户：

感谢您选购得胜MS830/MS831/MS832有线会议麦克风，为了您能够更好地了解使用本产品，建议您在使用前仔细阅读本说明书。

若存在有疑问或者您有宝贵的建议，可通过拨打得胜官方服务热线400 6828 333或微信扫描二维码关注得胜官方公众号与我们联系。



■ 产品特性

MS830有线会议麦克风

- 采用超心型双极头设计，能够清晰地捕捉和传输声音，拾音音质更佳；
- 咪管采用双极头、干涉管音频处理技术，有效防止啸叫；
- 可拆卸电池，3V或48V幻象切换供电；
- 有效拾音角度100°可以防止邻近话筒干扰和抑制啸叫；
- 低阻抗200Ω的平衡音频输出；
- 外置防风棉把风声等噪声抗至最低，音质更清晰圆润；
- 采用锌基合金材质，灰黑色烤漆工艺，外观新颖，简约大方；
- 开机键亮红灯，屏幕显示“通话中”，可进行发言。

MS831有线会议麦克风

- 采用超心型双极头设计，能够清晰地捕捉和传输声音，拾音音质更佳；
- 方管采用双极头、干涉管音频处理技术，有效防止啸叫；
- 可拆卸电池，3V或48V幻象切换供电；
- 有效拾音角度100°可以防止邻近话筒干扰和抑制啸叫；
- 低阻抗200Ω的平衡音频输出；
- 内置防风棉把风声等噪声抗至最低，音质更清晰圆润；
- 会议座采用锌基合金材质，灰黑色烤漆工艺，外观新颖，简约大方；
- 纯铝四方管，金属网罩，拾音面积大，有效拾音距离10-100cm；
- 开机键亮红灯，屏幕显示“通话中”，可进行发言。

MS832有线会议麦克风

- 采用超心型多极头设计，能够清晰地捕捉和传输声音，拾音音质更佳；
- 双方管采用双极头、干涉管音频处理技术，有效防止啸叫；
- 可拆卸电池，3V或48V幻象切换供电；
- 有效拾音角度100°可以防止邻近话筒干扰和抑制啸叫；
- 低阻抗200Ω的平衡音频输出；
- 内置防风棉把风声等噪声抗至最低，音质更清晰圆润；
- 会议座采用锌基合金材质，灰黑色烤漆工艺，外观新颖，简约大方；
- 双纯铝四方管，金属网罩，拾音面积大，有效拾音距离10-100cm；
- 开机键亮红灯，屏幕显示“通话中”，可进行发言。

■ 适用范围

适用于会议、广播等场合

■ 产品配置

MS830

会议底座.....	1个
鹅颈咪杆.....	1支
连接线.....	2条
说明书.....	1份

MS831

会议底座.....	1个
方型单杆.....	1支
连接线.....	2条
说明书.....	1份

MS832

会议底座.....	1个
方型双杆.....	1支
连接线.....	2条
说明书.....	1份

■ 技术参数

- 拾音方式: 电容式
- 指向特性: 超心型指向
- 频率响应: 100-18000Hz
- 信噪比: >65dB
- 输出阻抗: 200Ω平衡
- 灵敏度: -38dB
- 拾音距离: 10-100cm
- 供电电压: 3V/48V
- 消耗电流: 14mA
- 颜色: 灰黑色烤漆
- 材质: 锌基合金
- 连接线长: 8m

注: 以上数据由得胜实验室测试得到, 并拥有最终解释权!

■ 安装说明

会议底座和咪杆组装须知

- 1.在同一包装内, 底座与咪杆是唯一对应的, 不得与其他包装内的咪杆混用。若强行混用, 可能会导致定位偏差, 影响咪杆指向的准确性。
- 2.在装接咪杆时, 请务必将咪杆的母座对准底座的公座并用力接入, 然后通过旋转咪杆上的固定螺母直至锁紧状态。安装时, 应旋转螺母而非直接旋转咪杆本身, 否则可能导致咪杆的母座损坏或拧断。
- 3.拆卸咪杆时, 先将咪杆上的固定螺母拧松, 确保螺母与螺芽全部分离后, 再将咪杆拔出即可。

■ 功能示意

- ① 电源开关：点按开启或关闭麦克风。
- ② 显示屏：开机屏幕显示“通话中”字样，关机时屏幕熄灭。
- ③ 咪杆连接座：用于安装和更换麦克风咪杆。
- ④ XLR接口：通过XLR音频线与调音台、幻象电源等设备连接。
- ⑤ 电池仓：用于安装2节AA电池。（注意电池极性）

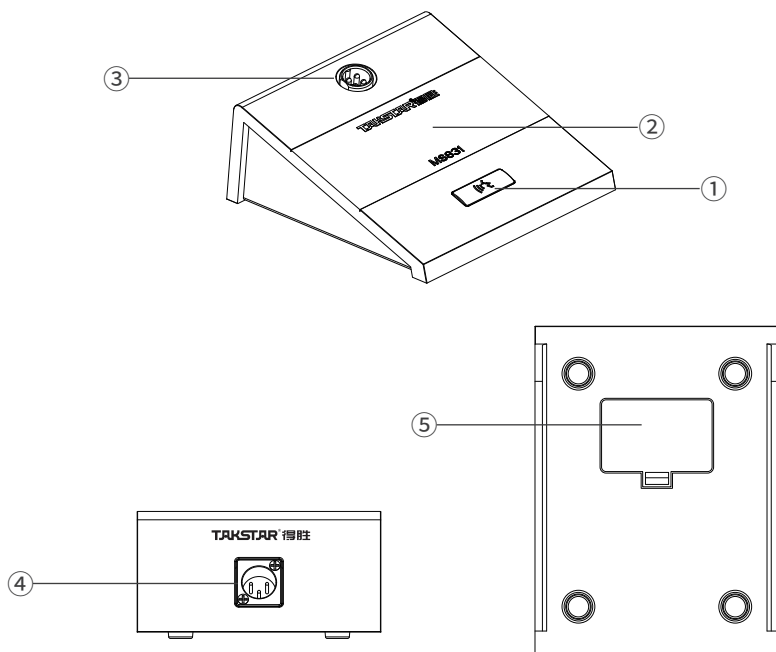

■ 使用说明

1. 打开麦克风底座下的电池盖，按照正确方向装入电池，卡上电池盖；如选择48V供电无需安装电池。
2. 将麦克风与卡侬输出线连接好，并连接至扩音设备输入插孔，如下图所示。
3. 使用时，应先将扩音设备音量旋钮控制在零位置，然后开启扩音设备和麦克风的电源开关，再将音量从小到大慢慢调节至合适位置。
4. 建议说话时，应与麦克风保持在10-100cm之间的拾音距离。
5. 当使用幻象电源供电时，将自动切断电池供电。

连接示意图

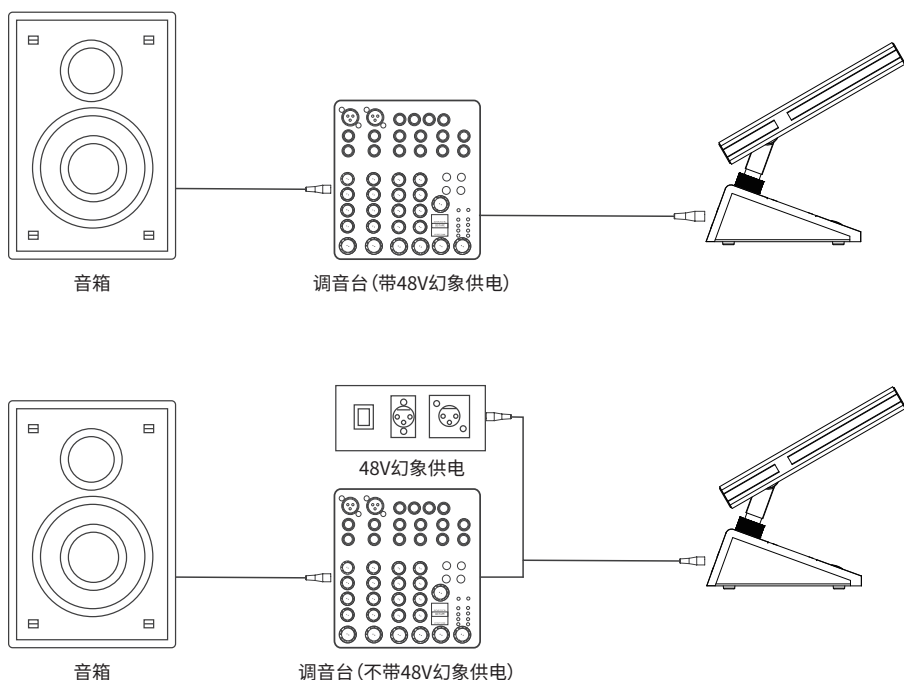

使用注意事项

1. 在使用过程中请勿用手握住会议麦克风拾音头部分，以免产生啸叫。
2. 会议麦克风灵敏度高，需注意不要从高处掉落或与其他物体产生强烈冲击，以免损坏拾音头。
3. 会议麦克风使用后，请将电池或电源取下，以免长时电池损耗而酸化，损坏内部精密元件。

■ 安全警示

为避免电击、高温、着火、辐射、爆炸、机械危险以及使用不当等可能造成的人身伤害或财产损失，使用本产品前，请仔细阅读并遵守以下事项：

1. 使用产品时请确认所连设备与本产品是否匹配以及合理调整音量大小，不要在超过产品功率及大音量下长时间使用，以免造成产品异常；
2. 使用中若发现有异常（如冒烟、异味等），请立即关闭电源开关并拔掉电源插头，然后将产品送售后服务网点检修；
3. 若产品需要使用可拆装电池时，严禁使用外壳绝缘材料破损的电池，请不要为非充电电池充电；
4. 废弃电池需放入指定的分类垃圾桶，不可作为儿童玩具或直接丢弃，以免造成安全隐患或影响环境；
5. 本产品及配件都应放置在室内干燥通风处，勿长期存放在潮湿、灰尘多的环境，使用中避免靠近裸露火源、碰到液体物质、雨淋、产品进水、过度碰撞、抛掷、振动本机及覆盖通风孔，以免损坏其功能；
6. 若产品需要固定于墙壁或天花板上时，请确保固定到位，防止因固定强度不足导致产品发生跌落危险；
7. 使用该产品时需遵守相关安全规定，法律法规明确禁止使用场合请勿使用本机，以免导致意外事故；
8. 请不要自行拆机改装或维修，以防止出现人身伤害，如有问题或服务需求请联系当地售后服务网点跟进处理；
9. 消费者若使用幻象电源供电，则应购买配套使用获得CCC认证并满足标准要求的幻象电源。

■ 环保说明

产品中有毒有害物质或元素的名称及含量标识表

部件名称	有毒有害物质或元素					
	铅 (Pb)	汞 (Hg)	镉 (Cd)	六价铬 (Cr(VI))	多溴联苯 (PBB)	多溴二苯醚 (PBDE)
塑料部件	○	○	○	○	○	○
金属部件	×	○	○	○	○	○
电路板组件	×	○	○	○	○	○
线缆	×	○	○	○	○	○

本表格依据SJ/T 11364的规定编制。
 ○: 表示该有害物质在该部件所有均质材料中的含量均在 GB/T 26572规定的限量要求以下。
 ×: 表示该有害物质至少在该部件的某一均质材料中的含量超出 GB/T 26572规定的限量要求。

此标志为产品的环保使用期限标志，
 且此环保使用期限只适用于产品正常工作的温度和湿度等条件。



■ 关于图标含义解释

 此符号表示，根据WEEE指令(2012/19/EU)和国家法律，由于这种类型的废弃物会有潜在的有害物质，可能对环境 and 人类健康产生负面影响，
 所以本产品不应与您的家庭垃圾一起处置，应将本产品交由授权的电气和电子设备 (WEEE) 回收站回收。同时，您在正确处理本产品的同时将有助于自然资源的有效利用。如需了解更多有关您可以在何处放置废物回收设备的信息，请联系您当地的城市办事处、废物管理局或家庭废物处理服务部门。

■ 关于本说明书

本说明书中内容符合截止印刷之日的技术规格。由于得胜公司会不断改进产品，本说明书可能不符合您的特定产品的技术规格。要获取最新版说明书，请访问得胜官网，然后下载说明书文件。技术规格、设备或另售的附件在各个地区可能有所不同，如有问题请与当地得胜销售网点确认。如需更多支持和深层产品信息，请浏览得胜官方网站：<https://www.takstar.com>

版权所有 ©2024 得胜。得胜、TAKSTAR及其各自标志是广东得胜电子有限公司在中国和/或其他国家/地区的注册商标或商标。所有其它商标均是其各自所有者的财产。

注意事项：

1. 本单为保修凭证，请用户妥善保管，如有遗失，恕不保修或退换。
2. 保修期限制：购买之日起十二个月内。
3. 除了不可抗力事件损坏外，由本公司负责，免费维修。
4. 如属保管不善或使用不当造成的损坏，维修点将酌情收费。
5. 擅自拆卸维修者，不予保修。
6. 以上保修条款仅限于中国市场适用（不含港澳台地区）。

产品服务保证书

姓名：_____ 电话：_____ 地址：_____

商品：_____ 型号：_____ 购买日期：____年__月__日

维修记录栏（由维修员填写）	维修员签名	日期

◆广东得胜电子有限公司 ◆电话：400-6828-333 ◆地址：广东省惠州市博罗县龙溪街道富康一路2号

■ Preface

Dear Customer,

Thank you for purchasing Takstar MS830/MS831/MS832 Wired Conference Microphone. To better understand and use the product, please read this manual thoroughly. If you have any questions or suggestions, please contact our local sales service.

■ Features

MS830 Wired Conference Microphone

- Supercardioid dual-capsule design, superior audio quality.
- Dual-capsule and interference tube technology prevent feedback.
- Removable battery, 3V/48V power supply switchable.
- 100° effective pickup angle, suppresses nearby interference.
- Low impedance balanced audio output (200Ω).
- External windscreen for minimum wind noise and clearer sound.
- Zinc-based alloy construction with gray-black powder coating and sleek design.
- Power button with red backlight, screen with in-call status display.

MS831 Wired Conference Microphone

- Supercardioid dual-capsule design, superior audio quality.
- Dual-capsule and interference tube technology prevent feedback.
- Removable battery, 3V/48V power supply switchable.
- 100° effective pickup angle, suppresses nearby interference.
- Low impedance balanced audio output (200Ω).
- Built-in windscreen for minimum wind noise and clearer sound.
- Zinc-based alloy conference base with gray-black powder coating and sleek design.
- Pure aluminum square tube mic with metal mesh cover, large pickup area, effective pickup distance of 10-100cm.
- Power button with red backlight, screen with in-call status display.

MS832 Wired Conference Microphone

- Supercardioid multi-capsule design, superior audio quality.
- Dual square tube mic design, each with dual-capsule and interference tube technology to prevent feedback.
- Removable battery, 3V/48V power supply switchable.
- 100° effective pickup angle, suppresses nearby interference.
- Low impedance balanced audio output (200Ω).
- Built-in windscreen for minimum wind noise and clearer sound.
- Zinc-based alloy conference base with gray-black powder coating and sleek design.
- Dual pure aluminum square tube mic with metal mesh cover, large pickup area, effective pickup distance of 10-100cm.
- Power button with red backlight, screen with in-call status display.

■ Applications

Meetings, broadcasts, and similar occasions.

■ Package Contents

MS830

- 1 × Conference Base
- 1 × Gooseneck Plug-in Mic
- 2 × Connection Cable
- 1 × User Manual

MS831

- 1 × Conference Base
- 1 × Square Tube Plug-in Mic
- 2 × Connection Cable
- 1 × User Manual

MS832

- 1 × Conference Base
- 1 × Dual-Square-Tube Plug-in Mic
- 2 × Connection Cable
- 1 × User Manual

■ Specifications

- Transducer: Condenser
- Polar Pattern: Supercardioid
- Frequency Response: 100-18000Hz
- Signal-to-Noise Ratio: >65dB
- Output Impedance: 200Ω balanced
- Sensitivity: -38dB
- Pickup Distance: 10-100cm
- Power Supply Voltage: 3V/48V
- Current Consumption: 14mA
- Color: Gray-black paint
- Material: Zinc-based alloy
- Cable Length: 8m

Note: The above data are measured by Takstar laboratory which has the final interpretation right!

■ Installation Instructions

Conference Base and Plug-in Mic Assembly Notes

1. Only use the plug-in mic that corresponds to the conference base in the same package. Mixing with plug-in mics from other packages may cause positioning errors, affecting the mic's accuracy.
2. When connecting the plug-in mic, align the female socket with the male socket of the base and firmly insert it. Securely lock the mic by rotating the fixing nut. Rotate the nut, not the mic itself, to avoid damaging the socket.
3. To remove the plug-in mic, loosen the fixing nut, separate it completely from the screw thread, and slide out the plug-in mic.

■ Function Descriptions

- ① Power Switch: Press to turn the mic on or off.
- ② Display Screen: "In call" displayed when powered on, screen turns off when powered off.
- ③ 4-Pin Mic Socket: Used for installing and replacing the plug-in mic.
- ④ XLR Connector: Connects to audio equipment such as mixing consoles and phantom power via an XLR audio cable.
- ⑤ Battery Compartment: Used for installing 2 AA batteries. (Pay attention to battery polarity)

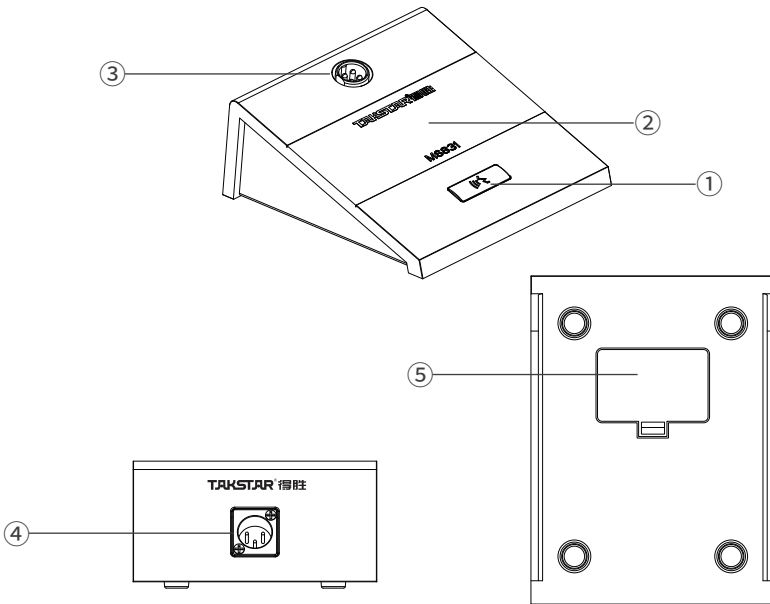

■ Operating Instructions

1. Open the battery cover located at the bottom of the mic base. Insert the batteries in the correct orientation and secure the battery cover. If using 48V power supply, there is no need to install batteries.
2. Connect the mic to the XLR output cable and connect it to the input jack of the amplification device, as shown in the diagram below.
3. Ensure that the volume control knob of the amplification device is set to zero before use. Then, turn on the amplification device and the mic. Gradually adjust the volume from low to high until it reaches a suitable level.
4. It is recommended to maintain a pickup distance between 10-100cm while speaking.
5. When using phantom power supply, the AA battery power will be automatically cut off.

Connection Diagram

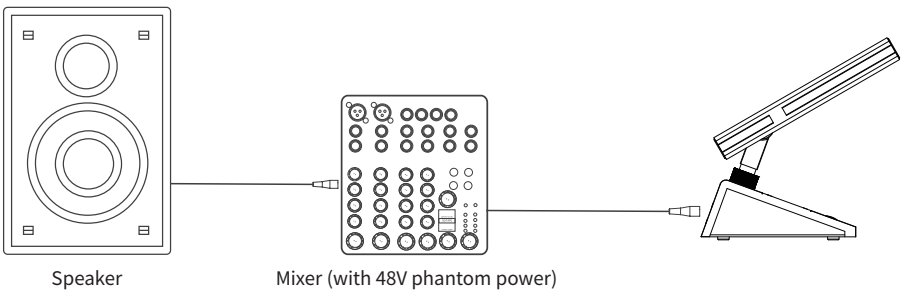

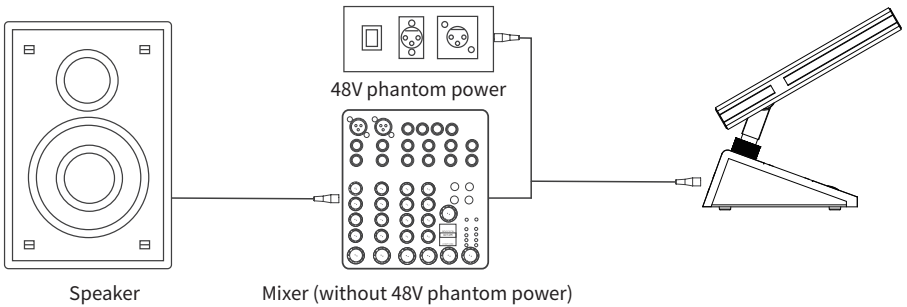

Precautions for Use

1. Do not hold the mic pickup head with your hand during use to avoid feedback.
2. The conference mic has high sensitivity. Avoid dropping it from a height or subjecting it to strong impacts to prevent damage to the capsule.
3. After use, remove the batteries or power supply to prevent prolonged battery drain and potential damage to internal components.

■ Safety Instructions

To avoid electric shock, overheat, fire, radiation, explosion, mechanical risk and injury or property loss due to improper use, please read and observe the following items before use:

1. Please check if the power of the connected equipment matches with that of this product before operation. Adjust the volume to proper level during operation. Do not operate at over-power or high-volume level for extended time to avoid product malfunction.
2. If there is any abnormality during use (e.g., smoke, strange odor), please kill the power switch and unplug from power source, then send the product to the local after-sales service for repair.

3. For products that require removable batteries, never use damaged batteries with broken insulation materials. Do not attempt to charge non-rechargeable batteries.
4. Dispose of used batteries in designated recycling bins. Do not use them as toys or dispose of them directly, as it may pose safety hazards or harm the environment.
5. Keep this product and its accessories in a dry and ventilated area. Do not store in a humid or dusty area for extended time. Keep away from fire, rain, liquid intrusion, bumping, throwing, vibrating, or from blocking any ventilation openings, to prevent malfunction.
6. The product must, when installed on walls or ceilings, be fixed firmly in place at adequate strength to prevent from falling.
7. Please abide by safety rules during operation. Do not use the product in places prohibited by laws or regulations to avoid accident.
8. Do not disassemble or repair the product by yourself to avoid personal injury. If you have question or need service, please contact our local after-sales service.
9. If you need to use a phantom power supply, make sure to purchase one that is CCC certified and meets the required standards.

■ Label Meanings



This symbol indicates that this product should not be disposed of with your household waste, according to the WEEE directive (2012/19/EU) and your national law. This product should be handed over to an authorized collection site for recycling waste electrical and electronic equipment (WEEE). Improper handling of this type of waste could have a possible negative impact on the environment and human health due to potentially hazardous substances that are generally associated with WEEE. At the same time, your cooperation in the correct disposal of this product will contribute to the effective usage of natural resources. For more information about where you can drop off your waste equipment for recycling, please contact your local city office, waste authority, or your household waste disposal service.

■ About This Manual

This manual contains up-to-date technical specifications as of printing. However, specifications contained herein may not conform to your particular product since Takstar is constantly improving its products. Also, specifications, devices or accessories available may vary from region to region. If you have any questions, please contact our local sales outlet. For the latest version/more information, please visit our website: <https://www.takstar.com/>

Copyright ©2024 TAKSTAR. TAKSTAR, 得胜 and their respective logos are registered trademarks or trademarks of Guangdong Takstar Electronic Co., Ltd. in the PRC, and/or other countries. All other trademarks are the property of their respective owners.



扫一扫, 了解更多产品
Scan for more
product information

广东省电声工程技术研究开发中心 广东得胜电子有限公司制造

地址: 广东省惠州市博罗县龙溪街道富康一路2号

服务热线: 400 6828 333 传真: 0752 6383950

邮箱: xs@takstar.com

网址: www.takstar.com

Designed & Manufactured by:

Guangdong Takstar Electronic Co., Ltd.

Address: No.2 Fu Kang Yi Rd., Longxi Boluo
Huizhou, Guangdong 516121 China

Tel: 86 752 6383644 Fax: 86 752 6383952

Email: sales@takstar.com

Website: www.takstar.com