

TAKSTAR® 得胜

WDA-500

便携式音箱

Portable speaker



使用手册 User Manual

WDA-500 便携式音箱

中文目录	1-18
Content	19-37
前言	2
产品特性	2
适用范围	3
包装清单	3
技术参数	4
功能示意	5
一、音箱	5
二、手持麦克风	9
三、头戴麦克风	10
四、遥控器	11
使用方法	12
手持麦克风	
一、连接麦克风	12
二、麦克风正确握持方法	13
三、连接手机/电脑/调音台/声卡等设备	14
四、多台串联功能	14
五、对频方法	15
六、无线播放配对	15
头戴麦克风	
一、对频方法	15
二、蓝牙配对	16
充电示意	16
安全警示	17
关于图标含义解释	18
关于本说明书	18

■ 前言

尊敬的用户：

感谢您选购得胜 WDA-500便携式音箱，为了您能够更好的了解及使用本产品，建议您在使用前仔细阅读本说明书。

若存在有疑问或者您有宝贵的建议，可通过拨打得胜官方服务热线400 6828 333或微信扫描二维码关注得胜官方公众号与我们联系。



■ 产品特性

手持版

- 多功能便携式音箱，适用于户外表演、广场舞、促销、培训等场合；
- 配套无线麦克风，采用UHF技术，在无干扰、无障碍的环境下传输距离约40米；
- 内置5.25寸高性能的纸盆扬声器，大音量输出，提供强劲的现场音效；
- 具备无线播放功能，可连接手机、电脑、PAD等设备播放音乐；
- 支持插U盘及TF卡，具有音乐播放功能，可播放MP3、WAV音频格式文件；
- 支持高/低音及混响调节功能，支持闪避效果，满足不同场合应用需要；
- 具有一键录音功能，可录制存储WAV格式的音频文件；
- FM收音机功能，自动搜台保存，可保存50个频道；
- 配备红外无线遥控器，方便操控工作模式、音量调节、录音、选曲等；
- 音箱内置大容量锂电池，可循环充电使用，节能环保。

头戴版

- 多功能便携式音箱，适用于户外表演、广场舞、促销、培训等场合；
- 采用UHF无线传输技术，在空旷地带使用传输距离约40米；
- 内置5.25寸高性能的纸盆扬声器，大音量输出，提供强劲的现场音效；
- 具备无线播放功能，可连接手机、电脑、PAD等设备播放音乐；
- 支持插U盘及TF卡，具有音乐播放功能，可播放MP3、WAV音频格式文件；
- 支持高/低音及混响调节功能，支持闪避效果，满足不同场合应用需要；
- 具有一键录音功能，可录制存储WAV格式的音频文件；
- FM收音机功能，自动搜台保存，可保存50个频道；
- 配备红外无线遥控器，方便操控工作模式、音量调节、录音、选曲等；
- 音箱内置大容量锂电池，可循环充电使用，节能环保。

■ 适用范围

户外表演、广场舞、促销、培训

■ 包装清单

手持版

WDA-500 音箱	1台
无线麦克风	1支
遥控器	1个
电源适配器 (赠送)	1个
5号干电池	2节
7号干电池	2节
说明书	1份

头戴版

WDA-500 音箱	1台
头戴麦克风	1个
遥控器	1个
电源适配器 (赠送)	1个
7号干电池	2节
说明书	1份

■ 技术参数

主机（音箱）

频率响应: 20Hz-20KHz

扬声器: 5.25寸*1 (全频)

额定功率: 20W

峰值功率: 40W

媒体播放: TF卡/U盘, 支持64G及以下

媒体格式: MP3、WAV

电池类型: 锂离子电池

电池容量: 7.4V \approx 4400mAh

电源规格: DC 12V \approx 1A

充电时间: 约4小时

使用时间: 约20小时 (@60%音量)

产品尺寸: 285*151*338 mm (宽*深*高)

净重: 约2.9kg

发射器（无线麦克风）

拾音器: 动圈

指向性: 单指向

频率响应: 60Hz-18KHz

灵敏度: $-51 \pm 3\text{dB}$ (0db=1V/Pa/m at 1KHz)

UHF频率: 550MHz~590MHz

UHF使用距离: 空旷地带约40米

供电方式: 1.5V AA电池 (2节)

产品尺寸: $\Phi 36\text{mm} * 245\text{mm}$ (直径*长)

净重: 约255g

发射器（头戴麦克风）

拾音器: 背极式驻极体

指向性: 单指向

频率响应: 60Hz-16kHz

灵敏度: -51 至 -54dB

(0db=1V/Pa/m at 1kHz)

UHF频率: 550MHz~590MHz (分段)

UHF使用距离: 空旷地带40米

电池类型: 锂离子电池

电池容量: 3.7V \approx 400mAh

充电规格: USB 5V \approx 200mA

充电时间: 约2.5小时

使用时间: 约5小时

单机重量: 约39g

注: 以上数据由得胜实验室测试得到, 并拥有最终解释权!



■ 功能示意

一、音箱

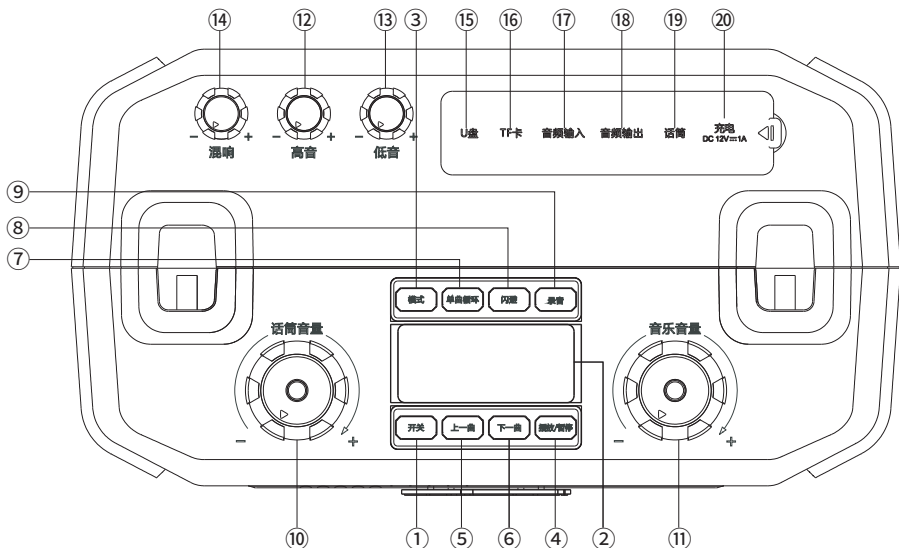
主机面板功能



- ① “开关” 按键：长按2秒开启或关闭音箱。开机时，LED显示屏出现“UHF”符号；关机时，语音提示“关机”，同时LED显示屏显示“OFF”符号后熄灭；
- ② LED显示屏：显示当前的工作模式、电池电量、播放时间、麦克风信号等信息；
- ③ “模式” 按键：循环点按切换5种工作模式，无线播放模式、TF卡模式、USB模式、收音模式及音频输入模式，并伴有相应的语音提示；
- ④ “播放/暂停” 按键：无线播放、TF卡模式及USB模式下，点按此键可暂停或播放音乐；在收音、音频输入模式下，点按此键可静音；在无线播放时，长按此键可以断开播放；收音模式下，长按此键进入自动收台，搜台过程中数值滚动显示，搜台结束后自动定格第一个频道播放。可以搜索保存50个频道以上，具体能保存多少个频道要视周边的电台信号强度而定；
- ⑤ “上一曲” 按键：点按切换上一曲；在收音模式下，点按切换上一个频道；
- ⑥ “下一曲” 按键：点按切换下一曲；在收音模式下，点按切换下一个频道；

- ⑦ “单曲循环” 按键：在TF卡或USB模式下播放音乐时，循环点按此键，切换为单曲循环或全曲循环播放；
- ⑧ “闪避” 按键：循环点按此键，打开或关闭闪避功能。在播放音乐并且打开话筒情况下，开启闪避功能，说话音乐音量会自动压低；关闭闪避，音乐恢复正常；
- ⑨ “录音” 按键：在插入TF卡及麦克风接通的状态下，循环点按，开启或关闭录音功能。开启录音时，语音提示“录音模式”，同时“REC”符号闪烁。录音过程中显示屏“00:00”数值变动，表示录音时长。录制过程中点按“录音”按键可结束并保存录音，同时语音提示“结束录音”，退出录音后会自动循环播放刚才的录音；
- ⑩ 话筒音量旋钮：顺时针旋转调大话筒音量，反之调小话筒音量；
- ⑪ 音乐音量旋钮：顺时针旋转调大音乐音量，反之调小音乐音量；
- ⑫ 高音旋钮：顺时针旋转提升音乐高频，反之衰减音乐高频；
- ⑬ 低音旋钮：顺时针旋转提升音乐低频，反之衰减音乐低频；
- ⑭ 混响旋钮：顺时针旋转调大话筒混响效果，反之调小话筒混响效果；
- ⑮ “USB” U盘接口：可插入U盘播放音频文件；
- ⑯ “” TF卡插槽：可插入TF卡播放音频文件或录音；
提示：请确保TF卡或U盘中储存的是MP3、WAV格式的音频文件，否则不能正常读取歌曲文件；拷入歌曲前请先将TF卡或U盘按FAT16、FAT32格式进行格式化，其它方式的格式化（如exFAT、NTFS格式）会导致录音无法保存或者储存的歌曲无法播放。
- ⑰ “Input” 音频输入接口：通过Φ3.5mm音频线，连接外部音源设备，如电脑、手机、平板、MP3播放器等；
- ⑱ “Output” 音频输出接口：通过Φ3.5mm音频线与另一台WDA-500音箱或其它音响串联；
- ⑲ “” 话筒接口：可连接Φ6.35mm接口的动圈麦克风；
- ⑳ 充电接口：通过标配的电源适配器为音箱充电。

LED数码显示屏

1. 开机符号：开机时，显示“UHF”符号；如图①
2. “”电量符号：电池电量充足时，电量符号不显示；当电池电量不足时，电量符号闪烁，并有语音提示：“电量不足，请充电”；充电时，电量符号显示，充满电后消失；如图①
3. 休眠符号：开机15分钟无任何操作时，显示屏出现“———”符号，表示音箱进入休眠省电状态，按任意键即可唤醒；如图②
4. 工作模式符号：显示当前工作模式，共以下5种工作模式：
 - (1)无线播放模式下，显示“bLUE”；如图③
 - (2)TF卡模式下，“00:00”表示音乐播放时间或录音时间。如图④
“0000”数值表示TF卡中歌曲序号。如图⑤
 - (3)USB模式下，“00:00”表示音乐播放时间。如图④
“0000”数值表示U盘中歌曲序号；如图⑤
 - (4)收音机模式下，“00.0”数值表示电台频率；如图⑥
 - (5)音频输入模式下，显示“AU”。如图⑦



图①



图②



图③



图④



图⑤



图⑥



图⑦



图⑧

5. 麦克风符号：麦克风连接成功时，出现“MIC”符号；断开麦克风连接时，“MIC”符号消失；如图⑦
6. 播放/暂停符号：播放音乐时，数码屏显示“00:00”数值开始变动；暂停音乐时，数码屏显示“PAUS”；如图⑧
7. 闪避符号：打开闪避时，显示“F ON”，如图⑨；关闭闪避时，显示“F OF”；如图⑩
8. 循环符号：在TF卡或USB模式下，显示“ALL”为全曲循环，如图⑪；显示“ONE”为单曲循环；如图⑫
9. 录音频符号：在插入TF卡及麦克风接通的状态下，开启录音，“00:00”数值变动，同时“REC”符号闪烁，如图⑬；录音过程，显示屏“00:00”数值表示录音时长；
10. Eq符号：6种均衡模式，对应显示Eq0至Eq5。如图⑭



图⑨



图⑩



图⑪



图⑫



图⑬



图⑭

二、手持麦克风

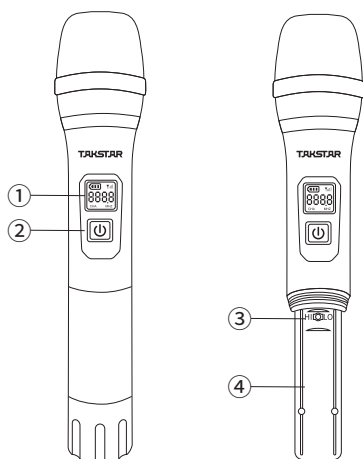

- ① 液晶显示屏：显示频率、麦克风信号、电池电量等信息；
- ② 电源按键：长按3秒开启或关闭麦克风；循环点按此键调节麦克风音量，分为（U08-U11）共4级音量，调节麦克风音量时音箱会同时发出“滴”的一声提示音；
- ③ “HI/LQ”按键：用于对频操作，详见本说明书“对频方法”部分；
- ④ 电池仓：装入2节1.5V AA电池。

麦克风显示屏



1. 电池电量：电池电量有三格，以格数表示电池电量，电量不足时，电池符号闪烁，请及时更换电池；
2. 信号符号：“”表示麦克风信号；

WDA-500 便携式音箱

3. 频率信息：显示当前麦克风的工作频率，（550MHz~590MHz）共40个频率；对频操作时，频率闪烁；
4. 音量信息：调节麦克风音量时，屏显示“U 00”表示当前麦克风音量等级，3秒后恢复显示频率信息。

麦克风电池安装

逆时针扭开麦克风尾盖，将2节5号干电池按电池仓标明的正负极性安装，注意电池极性不要装反；然后顺时针旋紧麦克风尾盖。如下图

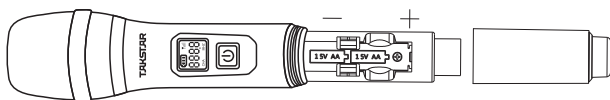

三、头戴麦克风

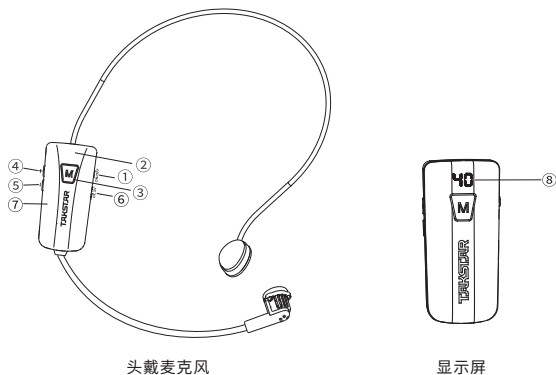

- ① 电源开关：拨动开关至ON时开机，拨开关至OFF时关机；
- ② 显示屏：显示工作频道、麦克风音量；
- ③ M按键：用于调频操作，详见本说明书的“对频方法”部分；
- ④ “+”按键：点按增加麦克风音量；在对频状态下，点按切换上一个频道，长按快速跳转频道；
- ⑤ “-”按键：点按减少麦克风音量；在对频状态下，点按切换下一个频道，长按快速跳转频道；

WDA-500 便携式音箱

- ⑥ 充电接口：连接USB数据线，请使用规范5V 1A且经过3C认证的充电头为扩音器充电；
- ⑦ 电源指示灯：关机未充电时，指示灯熄灭；开机时长亮蓝灯；电量充足时，指示灯常亮蓝灯；电量不足时，指示灯蓝灯闪烁；充电过程中，红灯长亮，充满后红灯熄灭；
- ⑧ 工作频道/麦克风音量：默认显示当前工作频道，有“01-40”共40个工作频道；当点按音量+、-键时，则显示音量大小，有“U1-U6”共6级音量，3秒后回复正常数值；10秒后无任何操作，显示屏将自动熄灭。

四、遥控器

遥控器面板功能

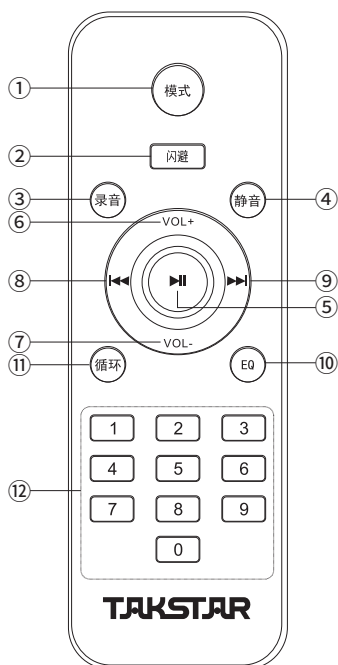

- ① “模式” 按键：切换音箱工作模式，详情参见主面板模式部分；
- ② “闪避” 按键：开启或关闭闪避功能，详情参见主面板闪避部分；
- ③ “录音” 按键：开启或结束录音功能，详情参见主面板录音部分；
- ④ “静音” 按键：循环点按静音按键，开启或关闭静音功能（不影响麦克风声音）；
- ⑤ “播放/暂停” 键：播放或暂停音乐，详情参见主面板播放/暂停部分；
- ⑥ “VOL+” 音量键：点按或长按此键音箱音量逐级增大（共 30 个音量等级可调节，调至30级时，有“滴”的一声提示音），不影响麦克风声音；
- ⑦ “VOL-” 音量键：点按或长按此键音箱声音逐级减小（共 30 个音量等级可调节），不影响麦克风声音；
- ⑧ “上一曲” 按键：点按跳转上一曲（长按可快退）和切换上一频道；
- ⑨ “下一曲” 按键：点按跳转下一曲（长按可快进）和切换下一频道；
- ⑩ “EQ” 按键：点按切换 6种音乐均衡效果，音箱显示屏对应显示 Eq0至 Eq5；
- ⑪ “循环” 按键：点按切换音乐播放顺序，详情参考主面板功能部分；
- ⑫ “0-9” 数字键：在TF卡和USB模式下，可输入数值，转跳至对应序号的歌曲进行播放。

■ 使用方法

手持麦克风

一、连接麦克风

可根据实际使用需求，选择使用有线或无线麦克风，使用有线麦克风时，将动圈麦克风接入音箱的 $\Phi 6.35\text{mm}$ 麦克风接口即可；使用无线麦克风时，打开音箱及无线麦克风即可自动完成对频，如麦克风没有声音可参照对频方法部分完成对频。如图所示

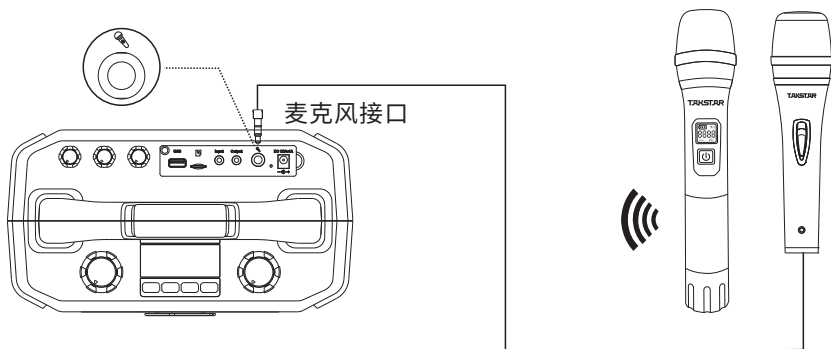

二、麦克风正确握持方法

1. 嘴部与麦克风保持距离建议在5~15CM之间。太近会引起调制过大而产生信号失真，太远的灵敏度使调制度不够，将会降低信噪比；
2. 手握麦克风管体中间部位，不能用手捂住麦克风网头，否则容易产生啸叫，也不要用手握住麦克风尾部，以免影响麦克风信号；
3. 尽可能的拉开麦克风与音箱的距离，避免麦克风和音箱相对，以免产生回馈啸叫。

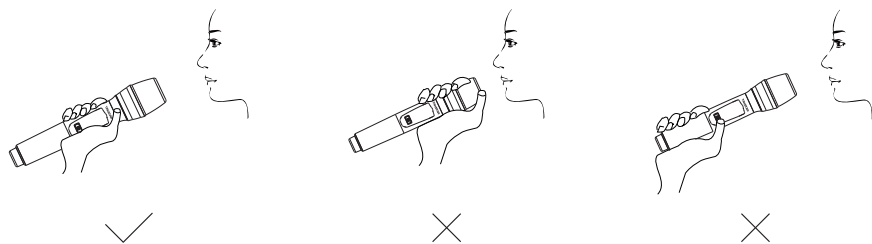

握持示意

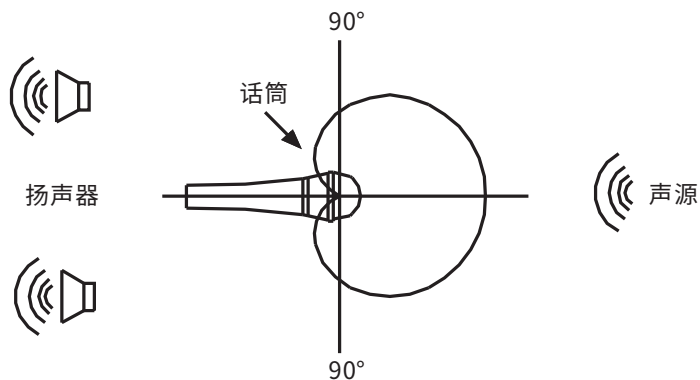

WDA-500 便携式音箱

三、连接手机/电脑/调音台/声卡等设备

将 $\Phi 3.5\text{mm}$ 音频线的一头与音箱的 $\Phi 3.5\text{mm}$ 音频输入接口连接，另一端与手机、电脑、声卡等音频设备的输出接口连接，如果手机没有 $\Phi 3.5\text{mm}$ 接口的，需配合OTG转接头使用（OTG转接头需自行另购）。如图所示

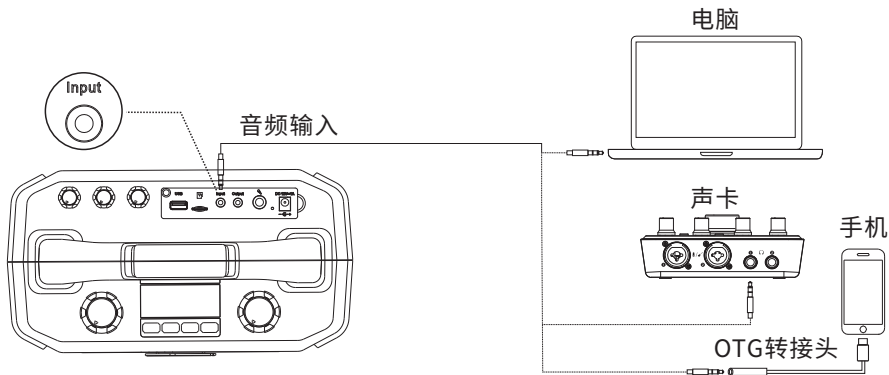

四、多台串联功能

WDA-500可支持串联，实现多台音箱同时扩音。使用串联时，将当前使用的WDA-500音箱通过 $\Phi 3.5\text{mm}$ 音频线从音频输出接口连接到第二台WDA-500音箱的 $\Phi 3.5\text{mm}$ 音频输入接口即可。如图所示

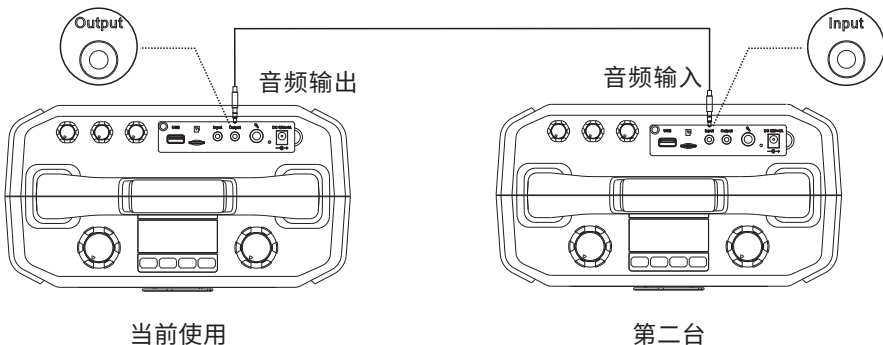

五、对频方法

产品出厂时已默认配对好，开机自动连接，无需配对。如遇有信号干扰，可按下面方法进行重新配对或变频。

1. 对频方法

- ① 首先无线麦克风及WDA-500音箱都保持关闭状态；
- ② 打开无线麦克风电源，扭开麦克风尾管，长按麦克风的“HI/LO”键3秒，待屏幕进入快闪状态后松开，此时立刻打开WDA-500音箱电源开关开始对频。如果10秒钟内没有打开音箱电源开关，则对频失败；
- ③ 对频大约在10秒钟内完成，当无线麦克风频率由闪烁变为长亮并且音箱显示屏出现“MIC”符号时，表示配对成功；若音箱没有出现“MIC”符号，则说明配对不成功，请按照上面方法重新配对。

2. 变频方法

同时打开音箱及无线麦克风电源开关，点按“HI/LO”键，即可切换频率，同时显示屏“00.0 MHz”数值变动。

六、无线播放配对

首次使用本机时，需要与手机或无线播放设备配对连接，步骤如下：

- ① 先打开音箱电源开关，短按“模式”键，当显示屏闪烁“bBLUE”符号时，表示正在搜索配对状态；
- ② 进入手机的“设置”菜单，开启手机的无线播放功能，待搜索到“TAKSTAR WDA-500”，点击“TAKSTAR WDA-500”进行连接。
- ③ 下次开机后选择到无线播放模式下，会自动回连最后一次使用的播放设备；
- ④ 在无线播放连接成功的情况下，长按“播放/暂停”按键断开播放。

头戴麦克风

一、对频方法

1. 配对方法

产品出厂时已默认配对好，开机自动连接，无需配对。如遇有信号干扰，可按下面方法进行重新配对或变频。

- ① 首先头戴麦克风及WDA-500音箱都保持关闭状态；
- ② 打开头戴麦克风电源开关，麦克风蓝灯长亮，然后长按麦克风“M”键3秒，待头戴麦克风显示屏显示转圈状态。此时立刻打开WDA-500音箱电源开关开始对频。如果10秒钟内没有打开音箱电源开关，则对频失败；
- ③ 对频大约在10秒钟内完成，当头戴麦克风蓝灯由闪烁变为长亮并且音箱显示屏出现

“MIC”符号时，表示配对成功；若音箱没有出现“MIC”符号，则说明配对不成功，请按照上面方法重新配对。

2. 变频方法

打开扩音器及头戴麦克风电源开关，确保在对频成功的情况下，短按头戴麦克风上的“M”键进入变频，显示屏数值闪烁，此时点按音量“+”、“-”切换上、下频率，或长按快速跳转频道，再点按“M”键确认频率，如3秒钟无操作“M”键确认，频率停止闪烁并固定在当前选择的频率。

3. 多台同时使用的方法

- ① 多台同时使用先按上述第一种“配对方法”重新连接一次后，再进行以下的变频操作；
- ② 先把第1个头戴麦克风短按1次“M”键变频，第2个头戴麦克风短按2次“M”键变频，第3个头戴麦克风短按3次“M”键变频....，以此类推，到操作完最后一个。一定要按顺序一个一个来操作。

二、蓝牙配对

首次使用本机时，需要与手机或无线播放设备配对连接，步骤如下：

- ① 先打开音箱电源开关，短按“模式”键，当显示屏闪烁“bLUE”符号时，表示正在搜索配对状态；
- ② 进入手机的“设置”菜单，开启手机的无线播放功能，待搜索到“TAKSTAR WDA-500”，点击“TAKSTAR WDA-500”进行连接。
- ③ 下次开机后选择到无线播放模式下，会自动回连最后一次使用的播放设备；
- ④ 在无线播放连接成功的情况下，长按“播放/暂停”按键断开播放。

■ 充电示意

1. 请使用标配的电适配器进行充电。将配套的电源适配器插入AC~220V电源插座，另一头插入本机DC插孔；
2. 音箱在开机状态下，电量符号“”闪烁，并有语音提示：“电量不足，请充电”，说明音箱电池电量不足；
3. 充电时，电量符号显示，表示正在充电中；电量符号消失，表示电已充满；
4. 使用标配的电源适配器为WDA-500音箱充电，约4小时可充满。当电池充满时，请停止对电池充电，避免电池过充。

提示：初次使用时，建议先充满电。如长时间不用，要每半年给音箱充一次电，避免电池过放，对电池性能产生影响。

■ 安全警示

为避免电击、高温、着火、辐射、爆炸、机械危险以及使用不当等可能造成的人身伤害或财产损失，使用本产品前，请仔细阅读并遵守以下事项：

1. 使用产品时请确认所连接设备与本产品功率是否匹配以及合理调整音量大小，不要在超过产品功率及大音量下长时间使用，以免造成产品异常和听力损伤；
2. 使用中若发现有异常（如冒烟、异味等），请立即关闭电源开关并拔掉电源插头，然后将产品送经销商检修；
3. 若产品需要使用可拆装电池时，严禁使用外壳绝缘材料破损的电池。请不要为非充电电池充电；
4. 废弃电池需放入指定的分类垃圾桶，不可作为儿童玩具或直接丢弃，以免造成安全隐患或影响环境；
5. 超过一周不使用本产品时，请取出电池，以免电池漏液导致产品损坏；
6. 本产品及配件都应放置在室内干燥通风处，勿长期存放在潮湿、灰尘多的环境，使用中避免靠近火源、雨淋、进水、过度碰撞、抛掷、振动本机及覆盖通风孔，以免损坏其功能；
7. 本产品内置的喇叭磁场较强，请将产品放置距离电脑或者电视机60CM以上的地方使用；
8. 若产品需要固定于墙壁或天花板上时，请确保固定到位，防止因固定强度不足导致产品发生跌落危险；
9. 使用该产品时需遵守相关安全规定，法律法规明确禁止使用场合请勿使用本机，以免导致意外事故；
10. 请不要自行拆机改装或维修，以防止出现人身伤害，如有问题服务需求请联系当地经销商跟进处理。未经同意对本设备进行自行拆机改装或维修，可能会失去由得胜公司提供的保修服务，请使用制造商指定的附件；
11. 若使用电源适配器为本产品充电，请使用赠送的电源适配器。如需使用其它适配器，应购买获得CCC认证并满足标准要求的电源适配器（电压小于12V且电流小于1A）；
12. 本产品适用海拔及气候条件由适配器决定，使用前请阅读并理解适配器上的图标含义。示例如下：



仅适用于海拔2000
米以下地区使用



仅适用于非热带气候条件
下使用

■ 关于图标含义解释



该图标表示产品所标配的适配器符合“中国强制性产品认证”3C认证要求。

SRRC

该图标表示产品符合国家无线电管理委员会的无线电型号的核准认证；



该图标表示设备仅适合室内使用



该图标表示设备符合二类电器双重绝缘要求。



此符号表示，根据WEEE指令(2012/19/EU)和国家法律，由于这种类型的废弃物会有潜在的有害物质，可能对环境 and 人类健康产生负面影响，所以本产品不应与您的家庭垃圾一起处置，应将本产品交由授权的电气和电子设备(WEEE)回收站回收。同时，您在正确处理本产品的同时将有助于自然资源的利用。如需了解更多有关您可以在何处放置废物回收设备的信息，请有效联系您当地的城市办事处、废物管理局或家庭废物处理服务部门。

■ 关于本说明书

本说明书中内容符合截止印刷之日的技术规格。由于得胜公司会不断改进产品，本说明书可能不符合您的特定产品的技术规格。要获取最新版说明书，请访问得胜官网，然后下载说明书文件。技术规格、设备或另售的附件在各个地区可能有所不同，如有问题请与当地得胜经销商确认。

如需更多支持和深层产品信息，请浏览得胜官方网站：<https://www.takstar.com/>

WDA-500 Portable speaker

Product	20
Features	20
Application	21
Product content	21
Specification	22
Function instruction	23
A. Speaker	23
B. Microphone	27
C. Headworn microphone	28
D. Remote control	29
Microphone Operation	30
Microphone	
A. Connecting with microphone	30
B. Holding microphone correctly	31
C. Connecting with cell phone/PC/mixer/sound card	32
D. Serial connection	33
E. Matching frequency	33
F. Matching for wireless playing	34
Headworn microphone	
A. Frequency Matching	34
B. Bluetooth Matching	35
Charging instruction	35
Caution	36
The meaning of Icon	37
About the user manual	37

WDA-500 Portable speaker

■ Product

Dear customer,

Thank you for purchasing WDA-500 portable speaker. Please read the manual carefully before operation and keep it for reference in future. If you have any question, please contact the local dealer.

■ Features

Handheld version

- The portable multifunction speaker, suitable for outdoor performance, square dance, promotion, training
- Designed with UHF wireless microphone, approximately 40m transmission range in open area without interference
- 5.25-inch high performance cone speaker, high volume output, powerful tone
- Wireless playing function, link with cell phone/PC/PAD to play music
- Playing music in USB stick or TF card, MP3/WAV format
- HF/LF/echo adjustment function and ducking function to meet the requirement of various applications
- Press one button to record, saving WAV format audio files
- FM radio function, automatically searching station, saving more than 50 channels
- Designed with infrared remote control to convenient operation mode, volume adjustment, recording and selecting songs
- High capacity Lithium battery, rechargeable, environment friendly

Head-mounted version

- The portable multifunction speaker, suitable for outdoor performance, square dance, promotion, training
- UHF wireless technology, approximately 40m transmission range in open area
- 5.25-inch high performance cone speaker, high volume output, powerful tone
- Wireless playing function, link with cell phone/PC/PAD to play music
- Playing music in USB stick or TF card, MP3/WAV format
- HF/LF/echo adjustment function and ducking function to meet the requirement of various applications
- Press one button to record, saving WAV format audio files
- FM radio function, automatically searching station, saving more than 50 channels
- Designed with infrared remote control to convenient operation mode, volume adjustment, recording and selecting songs
- High capacity Lithium battery, rechargeable, environment friendly

WDA-500 Portable speaker

■ Application

Outdoor performance, square dance, promotion, training

■ Product content

Handheld version

WDA-500 speaker	1pc
Wireless microphone	1pc
Remote control	1pc
Power adapter (Gift)	1pc
AA battery	2 pcs
AAA battery	2 pcs
User manual	1pc

Head-mounted version

WDA-500 speaker	1pc
Headworn microphone	1pc
Remote control	1pc
Power adapter (Gift)	1pc
AAA battery	2 pcs
User manual	1pc

WDA-500 Portable speaker

■ Specification

Speaker specification

Frequency Response: 20Hz-20KHz

Speaker: 5.25 inch *1 (full range)

Rated Power: 20W

Peak Power: 40W

Media Playing: TF card/USB, max 64G

Media Format: MP3, WAV

Battery: Li-ion battery

Battery Capacity: 7.4V \approx 4400mAh

Power Supply: DC 12V \approx 1A

Charging Time: approximate 4h

Operation Time: approximate 20h
(60% volume)

Dimension: 285X151 X 338 mm (WXDXH)

Net Weight: approximate 2.9kg

Transmitter (wireless microphone)

Cartridge: dynamic

Polar Pattern: unidirectional

Frequency Response: 60Hz-18KHz

Sensitivity: $-51 \pm 3\text{dB}$ (0db=1V/Pa/m
at 1KHz)

UHF: 550MHz~590MHz

Operation Range: approximate 40m
open area

Power Supply: 1.5V AA batteries (2)

Dimension: $\Phi 36\text{mm} \times 245\text{ mm}$ (dia*L)

Net Weight: approximate 255g

Transmitter (Headset microphone)

Cartridge: back electret

Polar Pattern: unidirectional

Frequency Response: 60Hz-16kHz

Sensitivity: -51 to -54dB
(0db=1V/Pa/m at 1kHz)

UHF Frequency: 550MHz~590MHz
(frequency band)

UHF Operation Range: open area 40m

Battery Type: Li-ion battery

Battery Capacity: 3.7V \approx 400mAh

Charging: USB 5V \approx 200mA

Charging Time: approximate 2.5h

Operation Time: approximate 5h

Net Weight: approximate 39g

Note: the above data are measured by Takstar laboratory and Takstar has the right of final interpretation.

Function instruction

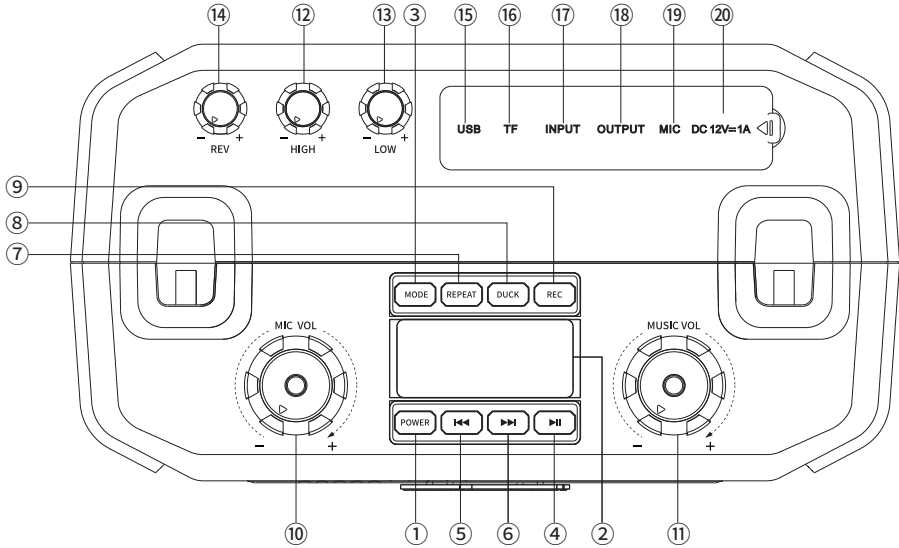

A. Speaker

Front panel function



- ① Power switch: keep pressing it for 2 seconds to turn on/off the speaker. After turning on, LED screen displays UHF symbol. After turning off, it has the sound prompt “ turning off ” , and OFF symbol on LED screen lights off.
- ② LED screen: displaying the current operation mode, battery power, playing time, mic signal, etc.
- ③ Mode button: press it to switch the modes: wireless playing mode, TF card mode, USB mode, radio mode and audio input mode, and there is relative ound prompt.
- ④ Play/Pause button: during wireless playing/TF card mode/USB mode, press this button to pause/play music. In radio/audio input mode, press it to mute. In wireless playing mode, keep pressing it to stop playing. In radio mode, keep pressing it to enter into auto searching station, and the number display changes. After searching station, it plays the first channel. It can search and save more than 50 channels (depending on actual environment).

WDA-500 Portable speaker

- ⑤ Previous song button: press it for previous song. In radio mode, press it for previous channel.
- ⑥ Next song button: press it for next song. In radio mode, press it for next channel.
- ⑦ Repeat button: in TF card/USB mode and playing music, press it to switching repeat single or all music playing.
- ⑧ Ducking button: press it to turn on/off ducking function. During music playing or mic on status, turn on this function. Turn off it and the speaker goes back to playing music.
- ⑨ Recording button: in TF card mode and mic on status, press it to turn on/off the recording function. When on, it has the sound prompt Recording mode, and REC symbol flashes. “00: 00” means the recording time. Press this button again to stop and save the recording, and it has the sound prompt Recording stopped. It exits the recording and plays the recording content.
- ⑩ Mic vol knob: turn it clockwise to increase the volume and vice versa.
- ⑪ Music vol knob: turn it clockwise to increase the volume and vice versa.
- ⑫ HF knob: turn it clockwise to increase the volume and vice versa.
- ⑬ LF knob: turn it clockwise to increase the volume and vice versa.
- ⑭ Echo knob: turn it clockwise to increase the mic echo effect and vice versa.
- ⑮ USB interface: link with USB to play audio file.
- ⑯ “” TF card slot: insert TF card to play audio file and record.
Note: please ensure audio format in TF card and USB is MP3/WAV, otherwise it can not read the files. Before copy the songs to TF card or USB, format it according to FAT16/FAT32. The other ways of format (e.g. exFAT, NTFS) lead to that the recording can not be saved or the songs can not be played.
- ⑰ “Input” audio in connector: linking with external audio source equipment, E.g. PC/cell phone/tablet PC/MP3 via $\Phi 3.5\text{mm}$ audio cable.
- ⑱ “Output” audio out connector: linking with other speaker via $\Phi 3.5\text{mm}$ audio cable.
- ⑲ “” mic connector: linking with dynamic mic of $\Phi 6.35\text{mm}$ connector.
- ⑳ Charging port: charging the speaker cabinet via power adapter.

WDA-500 Portable speaker

LED screen

1. Turning on symbol: after turning on, it displays UHF symbol. Refer to figure ①.
2. “” battery power: when the power is sufficient, it does not display the symbol. When insufficient, the symbol flashes, and it has the sound prompt “insufficient power, please charge” . During charging, the symbol is displayed. After being charged fully, the symbol disappears. Refer to figure ①.
3. Standby symbol: if there is no operation after turning on 15 minutes, it displays “— — — —” symbol. This means the speaker is in standby status. Press any button to wake up. Refer to figure ②.
4. Operation mode: it displays the current operation mode. There are 5 modes as below:
 - (1) In wireless playing mode, it displays “bLUE” . Refer to figure③.
 - (2) In TF card mode, “00: 00” means the music playing time and recording time. Refer to figure ④. “0000” means the song number in TF card. Refer to figure ⑤.
 - (3) In USB mode, “00: 00” means the music playing time. Refer to figure ④. “0000” means the song number in USB. Refer to figure ⑤ .
 - (4) In radio mode, “00.0” means the station frequency. Refer to figure ⑥.
 - (5) In audio input mode, it displays AU. Refer to figure ⑦.



Figure ①

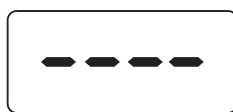

Figure ②



Figure ③



Figure ④



Figure ⑤



Figure ⑥



Figure ⑦



Figure ⑧

WDA-500 Portable speaker

5. Mic symbol: when mic is connected, it displays MIC symbol. When disconnected, the symbol disappears. Refer to figure ⑦.
6. Play/pause symbol: during music playing, it displays “00: 00” changing. When the music is paused, it displays “PAUS” . Refer to figure ⑧.
7. Ducking symbol: when on, it displays “F ON” . Refer to figure ⑨. When off, it displays “F OF” . Refer to figure ⑩.
8. Repeat symbol: in TF card or USB mode, it displays ALL for repeat all songs (refer to figure ⑪) or ONE for repeat one song (refer to figure ⑫).
9. Recording symbol: in the status of inserting TF card and connecting with mic, turn on recording. “00: 00” number changes and meanwhile “REC” symbol flashes. Refer to figure ⑬. During recording, “00: 00” number means the recording time.
10. EQ symbol: six types of EQ modes, EQ0 to EQ5. Refer to figure ⑭.



Figure ⑨



Figure ⑩



Figure ⑪



Figure ⑫



Figure ⑬



Figure ⑭

WDA-500 Portable speaker

B. Microphone

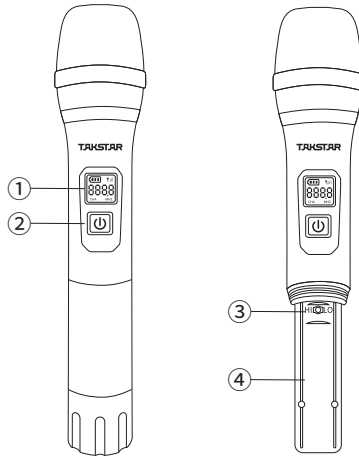

- ① LCD: displaying frequency, mic signal, battery power, etc;
- ② Power switch: keep pressing it for 3 seconds to turn on/off the microphone. Press it to adjust mic volume (U08-U11), totally four levels. When adjusting mic volume, the speaker has sound prompt.
- ③ “HI/LQ” button: used for matching frequency operation. Refer to “matching frequency” section in this manual for details.
- ④ Battery compartment: it loads two 1.5V AA batteries.

Mic display

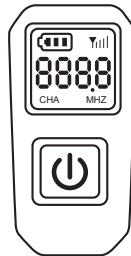

1. Battery power: three level in all. When the battery power is in sufficient, the symbol flashes. Please replace the batteries in time.
2. Signal symbol: “” means the mic signal.

WDA-500 Portable speaker

3. Frequency information: displaying the current mic operation frequency, (550MHz~590MHz) 40 frequencies in all. During frequency matching, it flashes.
4. Volume information: when mic volume is adjusted, the screen displays “U 00” . This means the mic volume level. After 3 seconds, it displays the frequency information.

Loading mic batteries

Turn the mic tail section counterclockwise to open the battery compartment and load two AA batteries according to correct polarity. Turn it clockwise to assemble. Refer to the figure below.

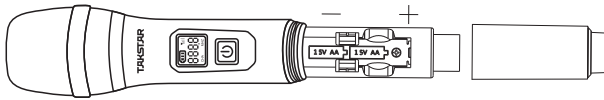

C. Headworn microphone

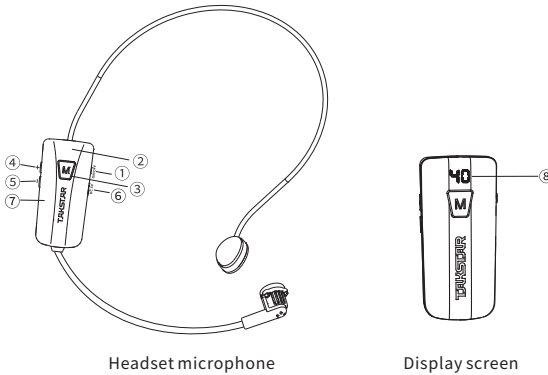

Headset microphone

Display screen

- ① Power switch: The microphone is turned on when the switch is in the ON position, and the microphone is turned off when the switch is in the OFF position.
- ② Display screen: Display working channel and microphone volume.
- ③ M button: Used for frequency matching. Refer to "matching frequency" section for details.
- ④ + button: Press it to increase the volume of the microphone. In the matching state, press it to switch to the previous channel, and long press it to quickly switch channels.
- ⑤ - button: Press it to decrease the volume of the microphone. In the matching state, press it to switch to the next channel, and long press it to quickly switch channels.

WDA-500 Portable speaker

- ⑥ Charging interface: Connect to the USB data cable. Please use a charging head with a specification of 5V 1A and 3C certification to charge the amplifier.
- ⑦ Power indicator: Off when powered off and not charging. Blue when powered on and having sufficient battery left. Flashes blue if low power. Red while charging and red light off when fully charged.
- ⑧ Working channel/microphone volume: The current working channel is displayed by default, and there are totally 40 working channels "01-40". When you press the volume+ and - buttons, the volume is displayed and returns to normal value after 3 seconds; there are totally 6 levels of volume "U1-U6". After 10 seconds without any operation, the display screen will automatically go out.

D. Remote control

Remote control panel function

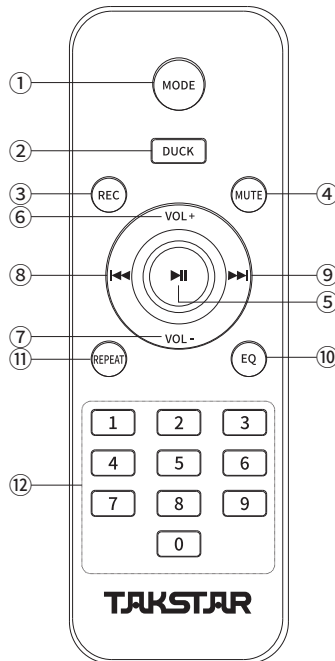

WDA-500 Portable speaker

- ① Button: switching operation mode. Refer to the panel mode section for Details.
- ② Ducking button: turning on/off ducking function. Refer to the ducking section for details.
- ③ Recording button: turning on/off recording function. Refer to the recording section for details.
- ④ Mute button: press it to turn on/off the mute function (does not affect mic Sound).
- ⑤ Play/pause button: play/pause music. Refer to play/pause section for details.
- ⑥ “VOL+” button: press it to increase the volume (30 levels in all. There is sound prompt when it is adjusted to the highest level). It does not affect the mic Sound.
- ⑦ “VOL-” button: press it to decrease the volume (30 levels in all). It does not affect the mic sound.
- ⑧ Previous song button: press it to adjust to previous song or channel (keep pressing it for fast forward).
- ⑨ Next song button: press it to adjust to next song or channel (keep pressing it for rewind).
- ⑩ EQ button: press it to switch 6 EQ effect, Eq0 ~ Eq5 displayed
- ⑪ Repeat button: press to switch music playing order. Refer to the panel function section for details.
- ⑫ “0-9” button: in TF card and USB mode, press the number for the relative song Playing.

■ Microphone Operation

Handheld version

A. Connecting with microphone

Select wired or wireless microphone according to actual requirement. If you select wired microphone, connect dynamic microphone with $\Phi 6.35\text{mm}$ of speaker cabinet. If you select wireless microphone, match the mic with speaker cabinet. If the mic has no sound, refer to the matching section for the matching details. Refer to the figure:

WDA-500 Portable speaker cabinet

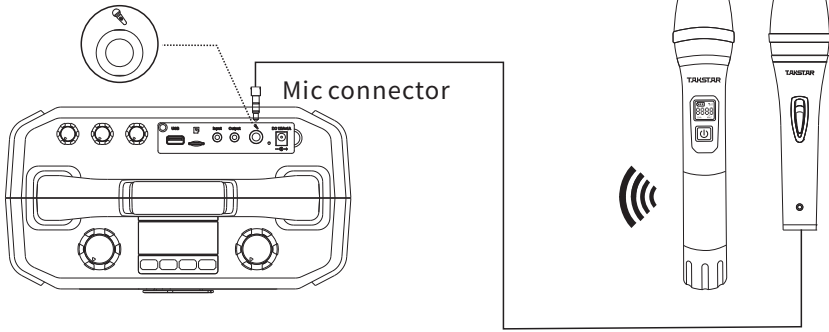

B. Holding microphone correctly

1. Put the mic away from you mouth in a range 5~15cm. Too close range leads to distortion due to over-modulation. Too far range decreases S/N ratio due to less modulation.
2. Hold the middle part of microphone. Do not hold the mic grille to avoid feedback. Do not hold the mic tail part to avoid affecting mic signal.
3. Put the mic away from speaker and do not point the cartridge to the speaker to avoid feedback.



Holding diagram

WDA-500 Portable speaker

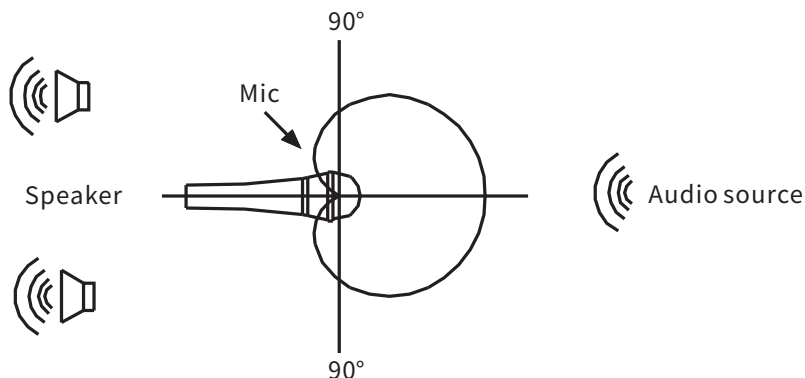

C. Connecting with cell phone/PC/mixer/sound card

Connect one end of $\Phi 3.5\text{mm}$ audio cable with $\Phi 3.5\text{mm}$ connector of speaker, and the other end with the output connector of cell phone/PC/sound card. If the cell phone has no $\Phi 3.5\text{mm}$ connector, use OTG adapter (buy additionally. Refer to the figure):

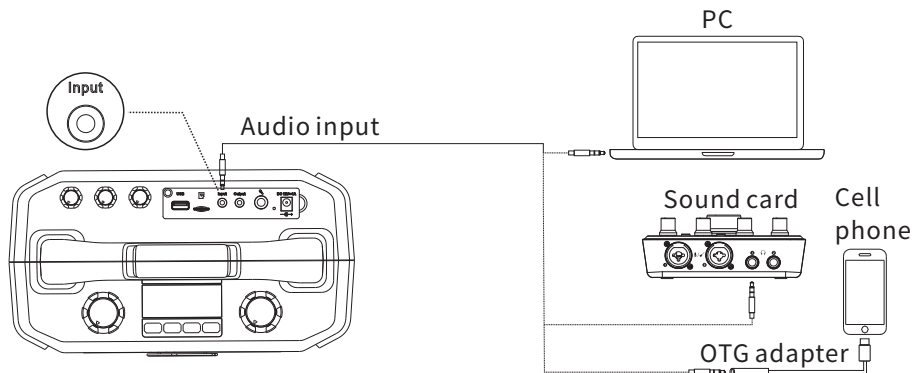

WDA-500 Portable speaker

D. Serial connection

WDA-500 supports serial connection for multiple speaker reinforcement simultaneously. Link the out connector of the first speaker with the in connector of the second one via $\Phi 3.5\text{mm}$ audio cable.

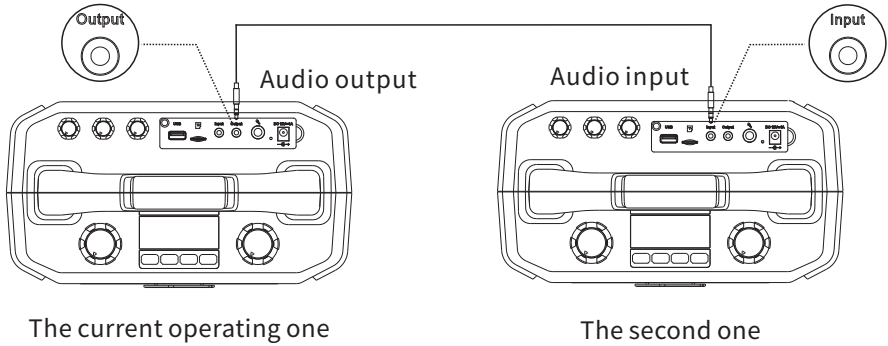

E. Matching frequency

This product has been matched well in factory. If there is signal interference, match again according to the steps below:

1. Matching

- ① At first, mic and speaker are in turning off status.
- ② Turn on wireless microphone. Disassemble the mic tail tube. Keep pressing "HI/LO" button for 3 seconds. When the screen flashes quickly, release it. Turn on the speaker at once for matching. If the speaker is not turned on in 10 seconds, the matching fails.
- ③ It takes about 10 seconds for matching. When wireless mic frequency turns flashing to lighting up and the speaker screen displays MIC, this means the matching is successful. If the speaker screen does not display MIC, this means the matching is unsuccessful. Matching them again according to the way mentioned above.

2. Changing frequency

Turn on the speaker and mic. Press "HI/LO" button to change frequency. The screen displays "00.0 MHz" with the number changing.

WDA-500 Portable speaker

F. Matching for wireless playing

If the speaker is used for the first time, it needs to match with cell phone or wireless playing equipment as the steps below:

- ① Turn on the speaker. Press mode button. When the screen flashes “bLUE” , this means it is in searching and matching status.
- ② Enter into cell phone Setting menu. Turn on the cell phone wireless function. When it searches “TAKSTAR WDA-500” , click “TAKSTAR WDA-500” for Connection.
- ③ When the speaker is turned on a second time and wireless mode is selected, it matches with the playing equipment matched previously.
- ④ In the status of matching is successful, keep pressing “play/pause” button to stop the playing.

Head-mounted version

A. Frequency Matching

1. Matching steps

It has the factory setting. If there is no interference, do not change frequency.

- ① First, keep the headworn microphone and WDA-500 speaker off.
- ② Turn on the headworn microphone, the indicator glows blue. Press and hold the M button of the microphone for 3 seconds until the microphone display shows a running circle. Then immediately turn on the WDA-500 speaker to start pairing. Pairing cannot succeed if the speaker is not turned on within 10 seconds.
- ③ The frequency pairing will complete within about 10 seconds. Pairing is successful when the light of the headset resumes solid blue and a MIC symbol appears on the speaker display. Otherwise, the pairing has failed, please retry above steps to re-pair.

2. Change frequency

Turn on the speaker and the microphone, make sure they are paired already. Press M button on the microphone, the display value will start blinking, then press or long press the volume +/- button to change frequency channel, and press M button again to confirm, or wait idle for 3 seconds to auto confirm current selection, the display will stop blinking.

WDA-500 Portable speaker

3. Multiple units used at the same time

- ① Use the first matching method to link and then change frequency .
- ② Press one time M button of the first microphone, and two times of the seconds, then three times of the third microphone, etc, operate the microphone one by one.

B. Bluetooth Matching

If the speaker is used for the first time, it needs to match with cell phone or wireless playing equipment as the steps below:

- ① Turn on the speaker. Press mode button. When the screen flashes “bLUE” , this means it is in searching and matching status.
- ② Enter into cell phone Setting menu. Turn on the cell phone wireless function. When it searches “TAKSTAR WDA-500” , click “TAKSTAR WDA-500” for Connection.
- ③ When the speaker is turned on a second time and wireless mode is selected, it matches with the playing equipment matched previously.
- ④ In the status of matching is successful, keep pressing “play/pause” button to stop the playing.

■ Charging instruction

1. Please use the standard adapter for charging. Use the standard to connect with AC~220V power socket and the speaker DC connector. Refer to the figure below:
2. When the speaker is turned on, the power symbol “” flashes and there is sound prompt: “insufficient power, please charge” . This means the low battery voltage.
3. During charging, it displays the power symbol. This means it is being charged. When the power symbol disappears, this means it is being charged fully.
4. Please use standard power adapter to charge WDA-500. It takes about 4h. When it is charged fully, please stop the charging.

Note: when it is used for the first time, it is recommended to charge it fully before operation. If it will not be used for a long time, please charge the speaker every half year to avoid over-discharging.

■ Caution

To avoid electric shock, over temperature, catching fire, explosion, mechanical risk and hurt or property loss caused by improper use, please read the following items carefully before operation:

1. Please check if the power of the connected equipment matches with that of this product before operation. Adjust the volume to proper level during operation. Do not operate at over-power or high volume level for a long time to avoid abnormal functioning or hearing loss.
2. If abnormal phenomenon (smoke, abnormal smell) happens, please turn off the power switch and disconnect the power plug with power socket, and send the product to local dealer for maintenance.
3. Using battery of broken insulation material is forbidden to avoid short circuit. Please do not charge the non-rechargeable battery.
4. Put the waste battery into classification dustbin rather than used as toy by children or discarded directly to avoid potential danger or affecting the Environment.
5. If this product will not be used for more than one week, take out the battery to prevent from damage due to battery leakage.
6. The product and accessories should be put in dry and ventilated place rather than humid or dusty environment. Prevent the product from liquid, rain, water, over-colliding, throwing, vibrating, vent hole covered to avoid function Destroyed.
7. Put the product 60cm away from PC/TV due to the strong magnetic field.
8. When the product needs to be installed on wall or ceiling, please fix it tightly to avoid dropping risk.
9. Please abide by safety rules during operation. Do not use the product in the place prohibited by regulation or law to avoid accident.
10. Do not disassemble or repair the product by yourself to avoid hurt. If you have question or need service, please contact the local dealer. Please use the accessories designated by supplier.
11. Please use the supplied adapter for charging. If you want to buy one, please buy one with CCC certification and meeting the requirement of standard (voltage less than 12V and current less than 1A).

WDA-500 Portable speaker

12. The applicable altitude and climate condition of this product is subject to the Power adaptor, the meaning of the power adaptor icons is as below:



Applicable to the altitude below 2000m only



Applicable to the non-tropical climate conditions only

■ The meaning of Icon



This icon indicates that the adapter of the product meets the 3C certification requirements of "China Compulsory Product Certification".

SRRC

The icon indicates that the product conforms to the radio approval certification of the National Radio Regulatory Commission.



This icon means the equipment is only suitable for indoor application.



The icon indicates that the equipment meets the double insulation requirements of class II electrical appliances.



This symbol indicates that according to WEEE Directive (2012 / 19 / EU) and national laws, this type of waste will have potential harmful substances, which may have a negative impact on the environment and human health, so this product should not be disposed together with your household waste, and should be handed over to the authorized electrical and electronic equipment (WEEE) recycling station for recycling. At the same time, when you handle this product correctly, it will help the effective use of natural resources. For more information on where you can place your waste recycling equipment, please contact your local city office, Waste Management Bureau or household waste treatment service.

■ About the user manual

For more information, please visit our website: <https://www.takstar.com/>. Takstar reserves the final interpretation right!

产品服务保证书

姓名：_____ 电话：_____ 地址：_____

商品：_____ 型号：_____ 购买日期：_____ 年 ___ 月 ___ 日

维修记录栏 (由维修员填写)	维修员签名	日期

注意事项：

1. 本单为保修凭证，请用户妥善保管，如有遗失，恕不保修或退换。
2. 保修期限制：购买之日起十二个月内。
3. 除了不可抗力事件损坏外，由本公司负责，免费维修。
4. 如属保管不善或使用不当造成的损坏，维修点将酌情收费。
5. 擅自拆卸维修者，不予保修。
6. 以上保修条款仅限于中国市场适用（不含港澳台地区）。



扫一扫，了解更多产品
Scan for more
product information

**广东省电声工程技术研究开发中心
广东得胜电子有限公司制造**

地址：广东省惠州市博罗县龙溪街道富康一路2号
服务热线：400 6828 333 传真：0752-6383950
邮箱：xs@takstar.com
网址：www.takstar.com

Guangdong Takstar Electronic Co., Ltd.
Address: No. 2 Fu Kang Yi Rd., Longxi Boluo
Huizhou, Guangdong 516121 China
Tel: 86 752 6383644 Fax: 86 752 6383952
Email: sales@takstar.com
Website: www.takstar.com
CMIIT ID: 2020DP12668 中国制造 Made in China

GB 8898-2011
9TSDA500S1C