

TAKSTAR® 得胜



XC-4R

无线一拖四麦克风

4-Channel Wireless Microphone System

使用手册 | User Manual

■ 前言

尊敬的用户：

感谢您选购得胜XC系列无线一拖四麦克风，为了您能够更好地了解使用本产品，建议您在使用前仔细阅读本说明书。

若存在有疑问或者您有宝贵的建议，可通过拨打得胜官方服务热线400 6828 333或微信扫描二维码关注得胜官方公众号与我们联系。



■ 产品特性

XC-4R无线麦克风主机

- 采用UHF频段设计，数字导频技术，有效避免干扰和串频现象，传输更可靠；
- DPLL数字锁相环多信道频率合成技术，在50MHz频率带宽内，以250KHz信道间隔，提供多达200个信道选择，支持多套叠机使用；
- 采用自动对频技术，迅速完成发射器与接收机频率同步，操作方便快捷；
- 特设高低功率切换功能，大型环境高功率发射（1000m²以上场所），小型环境可使用小功率发射；
- 信号稳定，使用距离远，空旷无遮挡地带下可达150米；
- 自动选讯功能，可快速准确地找出无干扰的可用信道，大大简化安装中的调试工作；
- 支持一键锁定功能，防止使用时误操作而导致设置状态更改；
- 具有50个预设频率组选择，方便多套同时使用频率灵活分配；
- 电子音量控制，调节范围0-39每步进2dBm，可根据不同场合精细化调整；
- 耳机监听功能，独立监听音量旋钮，方便安装或调试人员监听使用状况。

XC-TH会议座发射器

- UHF频段设计，数字导频技术，有效避免干扰和串频现象，支持多套同时使用；
- DPLL数字锁相环多信道频率合成技术，提供多达200个信道选择；
- 采用自动对频技术，迅速完成发射机与接收机频率同步，操作方便快捷；
- 传输信号稳定，空旷无遮挡地带下有效距离可达150米；
- 一键静音功能，随时开启或关闭声音信号，控制灵活；
- LCD液晶显示屏，可显示电量、频道等信息，方便用户实时了解工作状态；
- 可充电锂电池，支持Type-C充电，无需频繁更换电池；
- 电容式咪芯，灵敏度高拾音远，发言轻松，声音清晰自然；
- 会议底座可根据场合及需求与方形咪杆或鹅颈咪杆任意组合搭配使用。

XC-TD无线手持麦克风

- UHF频段设计，数字导频技术，有效避免干扰和串频现象，支持多套同时使用；
- DPLL数字锁相环多信道频率合成技术，提供多达200个信道选择；
- 采用自动对频技术，迅速完成发射机与接收机频率同步，操作方便快捷；
- 特设高低功率切换，大型环境高功率发射（1000m²以上场所），小型环境可使用小功率发射；
- 传输信号稳定，空旷无遮挡地带下有效距离可达150米；
- 采用高性能动圈拾音头，人声还原度高，说话轻松、清晰自然；
- LCD液晶显示屏，可显示电量、频道等信息，方便用户实时了解工作状态；
- 内置大容量可充电锂电池，支持Type-C充电，无需频繁更换电池。

XC-TP无线腰包麦克风

- UHF频段设计，数字导频技术，有效避免干扰和串频现象，支持多套同时使用；
- DPLL数字锁相环多信道频率合成技术，提供多达200个信道选择；
- 采用自动对频技术，迅速完成发射机与接收机频率同步，操作方便快捷；
- 传输信号稳定，空旷无遮挡地带下有效距离可达150米；
- 特设高低功率切换，大型环境高功率发射（1000m²以上场所），小型环境可使用小功率发射；
- 支持一键锁定功能，防止使用时误操作而导致设置更改；
- LCD液晶显示屏，可显示电量、频道等信息，方便用户实时了解工作状态；
- 体积轻巧易于携带，配备头戴和领夹两种麦克风选择，满足不同场合需求。

■ 适用范围

适用会议、报告厅、多功能厅等专业扩声场合。

■ 产品配置

XC-4R

接收主机.....	1台
音频连接线.....	1条
电源适配器.....	1个
UHF天线.....	2支
说明书.....	1份

XC-TD

手持麦克风.....	1支
可充电锂电池.....	1个
充电线.....	1条

XC-TP

腰包发射器.....	1个
耳挂麦克风.....	1个
领夹麦克风.....	1个
AA电池.....	2节

XC-TH

会议底座.....	1个
可充电锂电池.....	1个
充电线.....	1条
方形咪杆.....	1只
鹅颈咪杆.....	1只

■ 技术参数

XC-4R接收机

- 接收机方式: 二次变频超外差
- 中频频率: 第一中频110MHz, 第二中频10.7MHz
- 无线接口: BNC/50Ω
- 灵敏度: 12dB μ V (80dBS/N)
- 灵敏度调节范围: 12-32dB μ V
- 杂散抑制: \geq 75dB
- 最大输出电平: +10dBV
- 电源规格: DC 12V/1A

XC-TH会议座发射器

- 天线路式: 内置螺旋天线
- 输出功率: 高功率20mW
- 杂散抑制: -60dB
- 鹅颈/方型咪杆拾音头: 电容式
- 电池: 2600mA 18650锂电池
- 使用时间: 连续工作大于10个小时

XC-TD手持发射器

- 天线路式: 内置螺旋天线
- 输出功率: 高功率 30mW; 低功率 10mW
- 杂散抑制: -60dB
- 手持麦克风拾音头: 动圈式
- 电池: 4.2V 2600mA 18650锂电池
- 使用时间: 30mW时大于6小时, 10mW时大于12小时

XC-TP腰包发射器

- 天线路式: 1/4波长鞭状天线
- 输出功率: 高功率10mW; 低功率3mW
- 杂散抑制: -60dB
- 领夹/耳挂拾音头: 电容式
- 电池: 2 \times 1.5V AA 电池
- 使用时间: 10mW时大于10个小时, 3mW时大于15小时

综合参数

- 频率范围: 610MHz-690MHz
- 调制方式: 宽带FM
- 可调范围: 60MHz
- 信道数目: 200
- 信道间隔: 300KHz
- 频率稳定度: $\pm 0.005\%$ 以内
- 动态范围: $>85\text{dB}$
- 最大频偏: $\pm 45\text{kHz}$
- 音频响应: 80Hz-18kHz ($\pm 3\text{dB}$)
- 综合信噪比: $>85\text{dB}$
- 综合失真: $\leq 0.5\%$
- 工作温度: -10°C 至 45°C
- 电源规格: DC 12V/1A

注: 以上数据由得胜实验室测试得到, 并拥有最终解释权!

■ 功能示意

接收机前面板

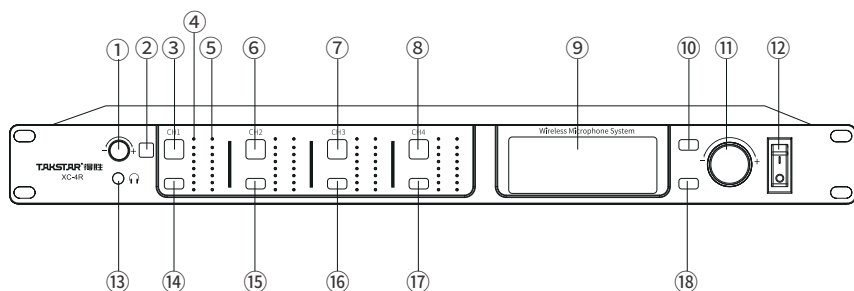

- | | | |
|---------------|---------------|--------------|
| ① 监听音量控制旋钮 | ⑦ 接收3通道显示屏切换键 | ⑬ 监听耳机接口 |
| ② 红外发射窗口 | ⑧ 接收4通道显示屏切换键 | ⑭ 接收1通道红外对频键 |
| ③ 接收1通道显示屏切换键 | ⑨ 显示屏 | ⑮ 接收2通道红外对频键 |
| ④ RF射频显示 | ⑩ 锁键 | ⑯ 接收3通道红外对频键 |
| ⑤ AF音量指示 | ⑪ 功能调节器 | ⑰ 接收4通道红外对频键 |
| ⑥ 接收2通道显示屏切换键 | ⑫ 电源开关 | ⑱ 自动搜索键 |

接收机后面板

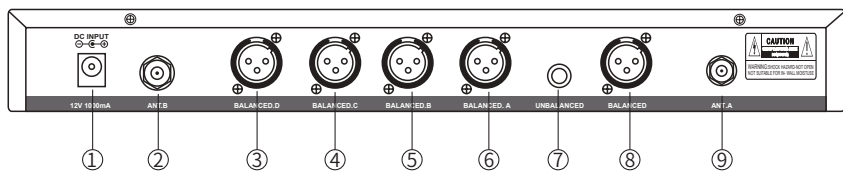

- ① 电源接口
- ④ 3接收通道平衡输出接口
- ⑦ 混合非平衡输出接口
- ② 3、4接收通道天线接口
- ⑤ 2接收通道平衡输出接口
- ⑧ 混合平衡输出接口
- ③ 4接收通道平衡输出接口
- ⑥ 1接收通道平衡输出接口
- ⑨ 1、2接收通道天线接口

显示屏界面

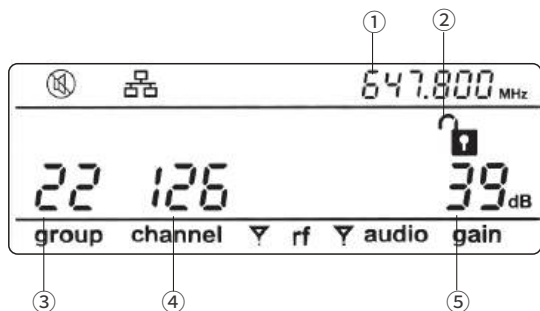

- ① 频率显示
- ② 锁键显示
- ③ 工作组显示
- ④ 频道显示
- ⑤ 音量显示

XC-TD手持发射器

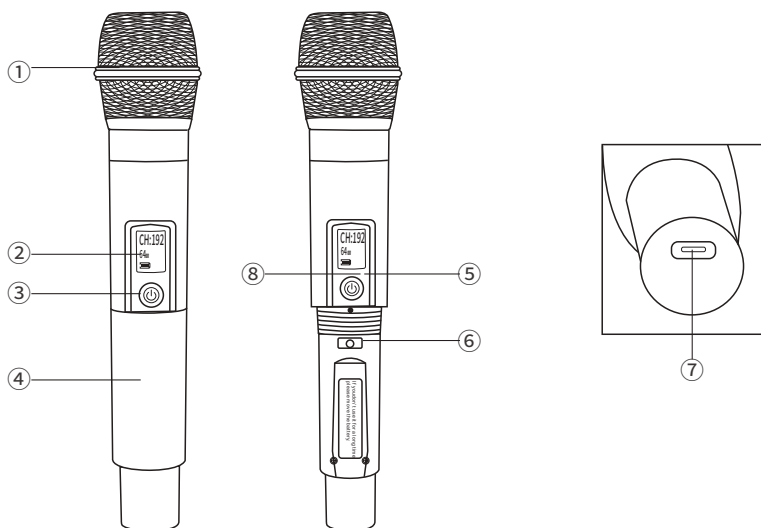

- ①网头及音头模组：此装置是将声音转换为音频信号的重要组成部分,网头内部的网棉可消除噪音,保护模组内部的拾音器。
- ②LCD液晶显示：显示信道、工作频率、电池电量、功率大小等信息。
- ③电源开关：长按开启或关闭麦克风电源。
- ④麦克风管体：管端装配网头、音头模组、管体内装电池、发射电路板、尾部内置发射天线等。
- ⑤红外对频窗口：配合接收机“Sync”对频键，将频率参数传至发射器。
- ⑥发射功率开关：开机状态下，长按进行功率大小调节，“P-Hi”表示大功率，“P-Lo”表示小功率。
- ⑦Type-C接口：使用Type-C充电线连接适配器为麦克风充电。
- ⑧电源指示灯：充电状态下，指示灯显示蓝灯，满电状态下，指示灯显示绿灯。

XC-TP腰包发射器

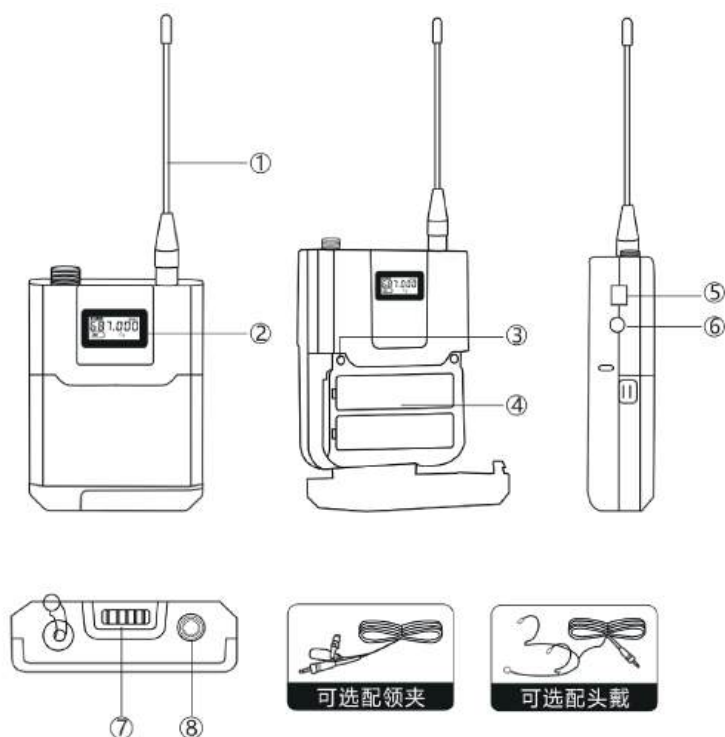

- ① 天线：为1/4波长鞭状天线。
- ② LCD液晶显示：显示电池电量、工作频道、功率状态等信息。
- ③ 红外对频窗口：配合接收机“Sync”键，将频率参数传至发射器。
- ④ 电池仓：装入两节AA电池。
- ⑤ 高低功率调节开关：开机状态下，长按进行功率大小调节，“RF-Hi”表示大功率，“RF-Lo”表示小功率。
- ⑥ 锁键开关：长按该按键可进行系统锁定或解锁操作。
- ⑦ 电源开关：拨至“ON”位置为开启电源，拨至“OFF”位置为关闭电源。
- ⑧ 麦克风输入接口：用于连接领夹或者头戴式麦克风。

XC-TH会议发射器

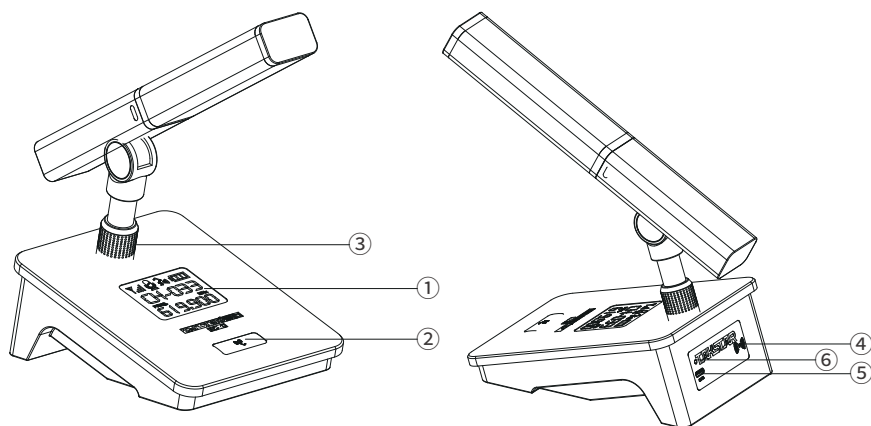

- ① 显示屏：显示当前拾音状态、电池电量、信道、频率等信息。
- ② 电源开关/静音开关：长按开启或关闭电源。开机状态下，点按该按键开启/关闭静音模式。
- ③ 4插针话筒输入插座：用于安装或更换麦克风咪杆。
- ④ 红外对频窗口：配合接收机“Sync”对频键，将频道参数传至发射器。
- ⑤ Type-C接口：使用Type-C充电线连接适配器为麦克风充电。
- ⑥ 电源指示灯：充电状态下，指示灯显示蓝灯；满电状态下，指示灯显示绿灯。

■ 使用说明

XC-4R接收机使用说明

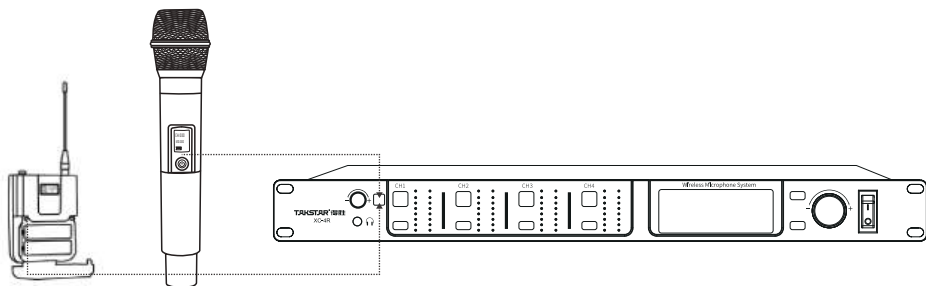

1. 对频功能操作

打开接收机和发射器的电源，将接收机的红外发射窗口，正对发射器的红外接收窗口，距离保持在30cm内，按下接收机上所需对频通道的“Sync”对频键，进入对频状态。待发射器频率与接收机频率一致，接收机上面有显示RF射频指示和电量指示，表示已完成对频操作。注：若对频失败，重复以上操作即可。

2. 自动搜索无干扰频点

开机状态下，长按接收机的“Scout”自动搜索键3秒，进入自动选讯功能，可快速准确地找出无干扰的可用信道。

3. 调频功能操作

选择好需要调整的接收通道，点按接收机的功能调节器中间位置，待显示屏的通道显示区域闪烁时，旋转功能调节器调整接收机频率，然后按功能调节器的中间位置进行确认保存。

4. 频率组选择操作

选择好需要调整的接收通道，点按接收机的功能调节器中间位置，待显示屏的工作组显示区域闪烁时，旋转功能调节器调整接收机工作组，然后按功能调节器的中间位置进行确认保存。

5. 音量大小调节

选择好需要调整的接收通道，点按功能调节器中间位置，待显示屏的音量显示区域闪烁时，旋转功能调节器调整音量大小，然后按功能调节器的中间位置进行确认保存。

6. 系统锁定/解锁操作

开机状态下，长按“Lock”键，即可锁定接收机，接收机处于锁定状态时所有功能按键不起作用。再长按“Lock”键可解锁，按键功能恢复。

XC-TD手持发射器使用说明

1. 长按电源开关将麦克风开机，LCD显示屏亮起，同时显示当前工作频道、电池电量等信息。
2. 如需更改工作频道，应首先改变接收机频道，然后将发射器的红外对频窗口和接收机上的红外对频窗口对准，并按接收机面板上的“Sync”对频键，将新的频道参数传至发射机。
(请参考接收机调频功能操作部分)

XC-TP腰包发射器使用说明

1. 安装电池: 打开腰包发射器电池仓, 将两节AA电池按电池仓标明的正负极性安装, 注意电池极性不要装反, 安装完成后合上电池仓。
2. 将头戴麦克风或夹领麦克风插头插入发射器的麦克风输入接口, 并锁紧固定。
3. 拨动腰包发射器电源开关至“ON”位置开机, 将发射器的红外接收窗口, 正对接收机的红外发射窗口, 距离保持在30cm内, 按下接收机上所需对频通道的“Sync”对频键进行对频。
3. 如需更改工作频道, 应首先改变接收机频道, 然后将发射器的红外对频窗口和接收机上的红外对频窗口对准, 并按接收机面板上的“Sync”对频键, 将新的频道参数传至发射机。
(请参考接收机调频功能操作部分)
4. 可根据实际情况, 调节发射器的功率大小。

XC-TH会议发射器使用说明

1. 将咪杆安装至会议发射器的4插针话筒输入插座。
2. 长按会议发射器的电源键开机, 将发射器的红外接收窗口, 正对接收机的红外发射窗口, 距离保持在30cm内, 然后按下接收机上所需对频通道的“Sync”对频键进行对频。
3. 会议发射器处于开机状态下, 点按电源键, 红色指示灯熄灭, 则麦克风为静音状态。
4. 建议说话时, 应保持20-50cm左右拾音距离。

故障排除

故障现象	故障原因
收发机无指示	发射器电池耗尽, 接收机电源未接好
接收机无射频信号	收发不同频或超出接收范围
有射频信号, 但无音频信号	发射器麦克风未接入或接收机静噪太深
	导音电路故障
	静音模式开启
音频信号背景噪声太大	发射调制频偏太小; 接收输出电平低; 可能存在干扰信号
音频信号失真	发射机调制频偏过大; 接收机输出电平过高
使用距离较短, 信号不稳定	发射机设置在小功率; 接收机静噪太深; 接收机天线设置不当, 周围有强电磁干扰

■ 安全警示

为避免电击、高温、着火、辐射、爆炸、机械危险以及使用不当等可能造成的人身伤害或财产损失，使用本产品前，请仔细阅读并遵守以下事项：

1. 使用产品时请确认所连设备与本产品是否匹配以及合理调整音量大小，不要在超过产品功率及大音量下长时间使用，以免造成产品异常；
2. 使用中若发现有异常（如冒烟、异味等），请立即关闭电源开关并拔掉电源插头，然后将产品送售后服务网点检修；
3. 若产品需要使用可拆装电池时，严禁使用外壳绝缘材料破损的电池，请不要为非充电电池充电；
4. 废弃电池需放入指定的分类垃圾桶，不可作为儿童玩具或直接丢弃，以免造成安全隐患或影响环境；
5. 本产品及配件都应放置在室内干燥通风处，勿长期存放在潮湿、灰尘多的环境，使用中避免靠近裸露火源、碰到液体物质、雨淋、产品进水、过度碰撞、抛掷、振动本机及覆盖通风孔，以免损坏其功能；
6. 若产品需要固定于墙壁或天花板上时，请确保固定到位，防止因固定强度不足导致产品发生跌落危险；
7. 使用该产品时需遵守相关安全规定，法律法规明确禁止使用场合请勿使用本机，以免导致意外事故；
8. 请不要自行拆机改装或维修，以防止出现人身伤害，如有问题或服务需求请联系当地售后服务网点跟进处理。
9. 建议您首次使用将锂电池充满电，以确保电池最佳性能。

■ 关于图标含义解释



此符号表示，根据WEEE指令(2012/19/EU)和国家法律，由于这种类型的废弃物会有潜在的有害物质，可能对环境 and 人类健康产生负面影响，所以本产品不应与您的家庭垃圾一起处置，应将本产品交由授权的电气和电子设备（WEEE）回收站回收。同时，您在正确处理本产品的同时将有助于自然资源的有效利用。如需了解更多有关您可以在何处放置废物回收设备的信息，请联系您当地的城市办事处、废物管理局或家庭废物处理服务部门。

■ 关于本说明书

本说明书中内容符合截止印刷之日的技术规格。由于得胜公司会不断改进产品，本说明书可能不符合您的特定产品的技术规格。要获取最新版说明书，请访问得胜官网，然后下载说明书文件。技术规格、设备或另售的附件在各个地区可能有所不同，如有问题请与当地得胜销售网点确认。

如需更多支持和深层产品信息，请浏览得胜官方网站：<https://www.takstar.com>
版权所有 ©2024 得胜。得胜、TAKSTAR及其各自标志是广东得胜电子有限公司在中国和/或其他国家/地区的注册商标或商标。所有其它商标均是其各自所有者的财产。

注意事项：

1. 本单为保修凭证，请用户妥善保管，如有遗失，恕不保修或退换。
2. 保修期限制：购买之日起十二个月内。
3. 除了不可抗力事件损坏外，由本公司负责，免费维修。
4. 如属保管不善或使用不当造成的损坏，维修点将酌情收费。
5. 擅自拆卸维修者，不予保修。
6. 以上保修条款仅限于中国市场适用（不包含港澳台地区）。

产品服务保证书

姓名：_____ 电话：_____ 地址：_____

商品：_____ 型号：_____ 购买日期：_____ 年 ___ 月 ___ 日

维修记录栏（由维修员填写）	维修员签名	日期

◆广东得胜电子有限公司 ◆电话：400-6828-333 ◆地址：广东省惠州市博罗县龙溪街道富康一路2号

■ Preface

Dear Customer,

Thank you for purchasing Takstar XC Series 4-Channel Wireless Microphone System.

To better understand and use the product, please read this manual thoroughly.

If you have any questions or suggestions, please contact our local dealer.

■ Features

XC-4R Wireless Receiver

- Utilizes UHF and digital pilot tone to avoid interference and crosstalk.
- DPLL multi-channel frequency synthesis provides up to 200 channel options with a 250KHz channel spacing within a 50MHz bandwidth for multi-system use.
- Automatic pairing enables quick sync of transmitters and receivers.
- High/low power switch for venues over/under 1000m².
- Stable 150m transmission range in line of sight.
- Automatic channel scanning simplifies installation.
- One-key lock prevents accidental changes.
- 50 preset frequency groups for flexible multi-system use.
- Electronic volume control from 0-39 in 2dBm increments.
- Headphone monitoring with independent volume control.

XC-TH Conference Base Transmitter

- UHF & digital pilot tone for interference-free communication.
- DPLL multi-channel frequency synthesis with 200 channel options.
- Quick and convenient automatic pairing.
- Stable signal transmission up to 150m in clear areas.
- One-key mute for flexible control.
- LCD screen for real-time status updates.
- Rechargeable lithium battery with Type-C charging.
- High-sensitivity condenser capsule for clear, natural sound.
- Compatible with gooseneck/rectangular plug-in mics for versatile use.

XC-TD Wireless Handheld Microphone

- UHF & digital pilot tone for interference-free communication.
- DPLL multi-channel frequency synthesis with 200 channel options.
- Quick and convenient automatic pairing.
- High/low power switch for venues over/under 1000m².
- Stable signal transmission up to 150m in clear areas.
- High-performance dynamic capsule for clear speech.
- LCD screen for real-time status updates.
- Built-in rechargeable lithium battery with Type-C charging.

XC-TP Wireless Bodypack Microphone

- UHF & digital pilot tone for interference-free communication.
- DPLL multi-channel frequency synthesis with 200 channel options.
- Quick and convenient automatic pairing.
- Stable signal transmission up to 150m in clear areas.
- High/low power switch for venues over/under 1000m².
- One-key lock function to avoid misoperation.
- LCD screen for real-time status updates.
- Compact and lightweight design, compatible with headset and lapel mics.

■ Applications

Pro sound amplification in conferences, lecture halls, multi-purpose halls, etc.

■ Package Contents

XC-4R

- 1 × Receiver
- 1 × Audio Cable
- 1 × Power Adapter
- 2 × UHF Antenna
- 1 × User Manual

XC-TD

- 1 × Handheld Mic
- 1 × Rechargeable Li-ion Battery
- 1 × Charging Cable

XC-TP

- 1 × Bodypack Transmitter
- 1 × Earset Microphone
- 1 × Lavalier Microphone
- 2 × AA Battery

XC-TH

- 1 × Conference Mic Base
- 1 × Rechargeable Li-ion Battery
- 1 × Charging Cable
- 1 × Rectangular Plug-in Mic
- 1 × Gooseneck Plug-in Mic

■ Specifications

XC-4R Receiver

- Receiver Type: Double-conversion superheterodyne
- Intermediate Frequency: 110MHz (1st IF), 10.7MHz (2nd IF)
- Wireless Interface: BNC/50Ω
- Sensitivity: 12dBμV (80dBS/N)
- Sensitivity Adjustment Range: 12-32dBμV
- Spurious Rejection: ≥75dB
- Maximum Output Level: +10dBV
- Power Supply: DC 12V/1A

XC-TH Conference Mic Base Transmitter

- Antenna Type: Built-in spiral antenna
- Output Power: High Power 20mW
- Spurious Rejection: -60dB
- Gooseneck/Rectangular Mic Capsule: Condenser
- Battery: 2600mA 18650 Li-ion
- Battery Life: Over 10 hours

XC-TD Handheld Transmitter

- Antenna Type: Built-in spiral antenna
- Output Power: High Power 30mW; Low Power 10mW
- Spurious Rejection: -60dB
- Handheld Mic Capsule: Dynamic
- Battery: 4.2V 2600mA 18650 Li-ion
- Battery Life: Over 6 hours at 30mW; Over 12 hours at 10mW

XC-TP Bodypack Transmitter

- Antenna Type: 1/4 wavelength whip antenna
- Output Power: High Power 10mW; Low Power 3mW
- Spurious Rejection: -60dB
- Lavalier/Earset Mic Capsule: Condenser
- Battery: 2 × 1.5V AA Batteries
- Battery Life: Over 10 hours at 10mW; Over 15 hours at 3mW

General Parameters

- Frequency Range: 610MHz-690MHz
- Modulation Method: Wideband FM
- Adjustable Range: 60MHz
- Number of Channels: 200
- Channel Spacing: 300KHz
- Frequency Stability: Within $\pm 0.005\%$
- Dynamic Range: >85dB
- Max Frequency Deviation: $\pm 45\text{kHz}$
- Audio Response: 80Hz-18kHz ($\pm 3\text{dB}$)
- Overall S/N Ratio: >85dB
- Overall Distortion: $\leq 0.5\%$
- Operating Temperature: -10°C to $+45^{\circ}\text{C}$
- Power Supply: DC 12V/1A

Note: The above data are measured by Takstar laboratory which has the final interpretation right!

Function Descriptions

Receiver Front Panel

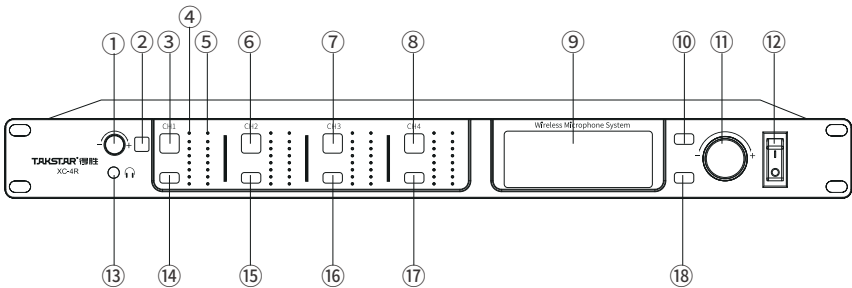

- | | |
|------------------------------------|-----------------------------------|
| ① Monitor Volume Control Knob | ⑩ Lock Key |
| ② Infrared Transmission Window | ⑪ Function Adjuster |
| ③ Display Switch Key for Channel 1 | ⑫ Power Switch |
| ④ RF Display | ⑬ Monitor Headphone Jack |
| ⑤ AF Volume Indicator | ⑭ Infrared Sync Key for Channel 1 |
| ⑥ Display Switch Key for Channel 2 | ⑮ Infrared Sync Key for Channel 2 |
| ⑦ Display Switch Key for Channel 3 | ⑯ Infrared Sync Key for Channel 3 |
| ⑧ Display Switch Key for Channel 4 | ⑰ Infrared Sync Key for Channel 4 |
| ⑨ Display Screen | ⑱ Auto Search Key |

Receiver Back Panel

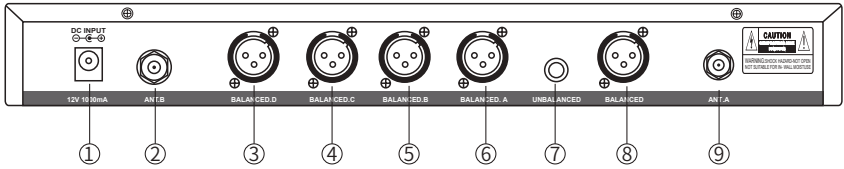

- ① Power Interface
- ② Antenna Interfaces for Channels 3 & 4
- ③ Balanced Output for Channel 4
- ④ Balanced Output for Channel 3
- ⑤ Balanced Output for Channel 2
- ⑥ Balanced Output for Channel 1
- ⑦ Mixed Unbalanced Output
- ⑧ Mixed Balanced Output
- ⑨ Antenna Interfaces for Channels 1 & 2

Display Screen Interface

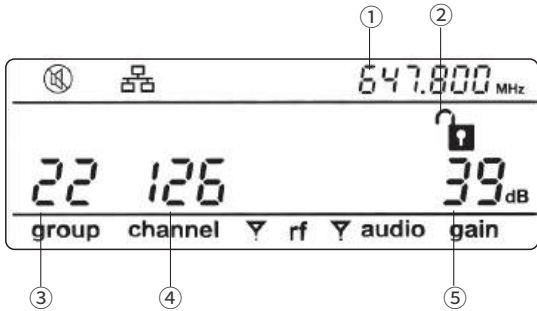

- ① Frequency info
- ② Lock status
- ③ Workgroup info
- ④ Channel info
- ⑤ Volume info

XC-TD Handheld Transmitter

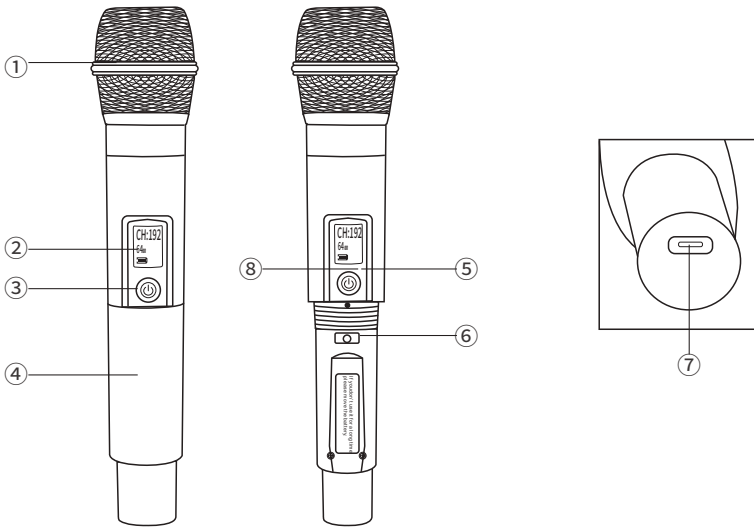

- ① Grille and Capsule: This device is a crucial component that converts sound into an audio signal. The foam lining inside the grille can eliminate noise and protect the mic element within the module.
- ② LCD Display: Shows channel, operating frequency, battery level, power level, and other info.
- ③ Power Switch: Press and hold to turn the mic power on or off.
- ④ Mic Body: On the top assembles the grille and capsule, inside houses the battery, transmission circuit board, with transmission antenna built in at the bottom.
- ⑤ Infrared Sync Window: Used with the receiver's "Sync" button to transmit frequency parameters to the transmitter.
- ⑥ Transmission Power Switch: When the power is on, press and hold to adjust the power level. "P-Hi" indicates high power, "P-Lo" indicates low power.
- ⑦ Type-C Interface: Use a Type-C charging cable to connect the adapter for mic charging.
- ⑧ Power Indicator: Displays blue while charging and turns green when fully charged.

XC-TP Bodypack Transmitter

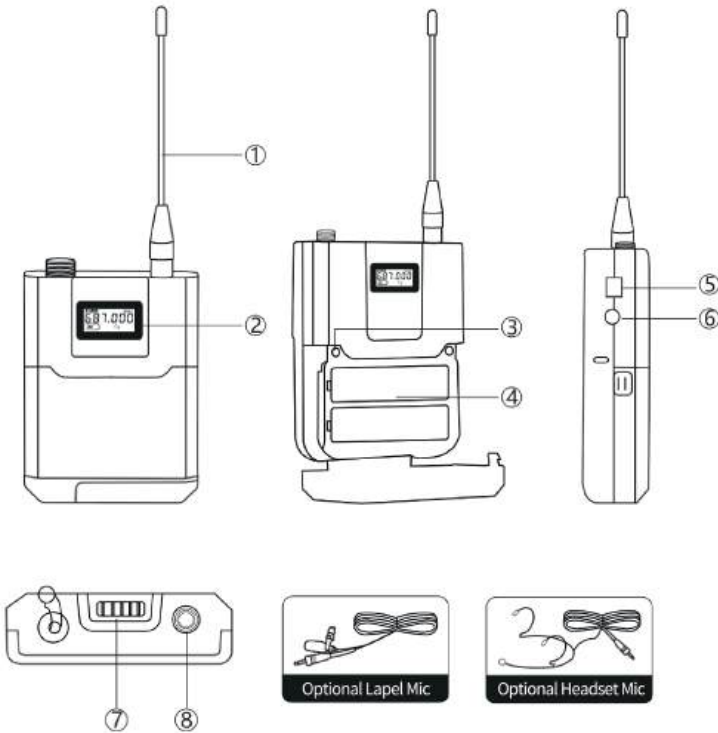

- ① Antenna: A 1/4 wavelength whip antenna.
- ② LCD Display: Shows battery level, working channel, power status, and other info.
- ③ Infrared Sync Window: Used with the receiver's "Sync" button to transmit frequency parameters to the transmitter.
- ④ Battery Compartment: Loads two AA batteries.
- ⑤ High/Low Power Switch: When the power is on, press and hold to adjust the power level. "RF-Hi" indicates high power, "RF-Lo" indicates low power.
- ⑥ Lock Key Switch: Press and hold to lock or unlock the system.
- ⑦ Power Switch: Set to "ON" to power on, set to "OFF" to power off.
- ⑧ Mic Input Jack: Used to connect a lavalier or headset mic.

XC-TH Conference Transmitter

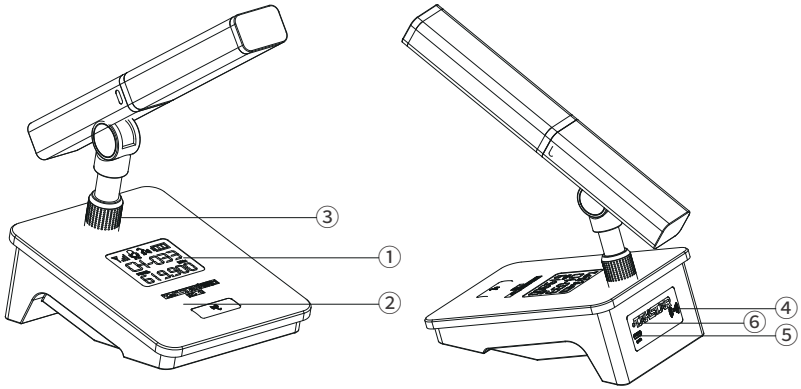

- ① Display Screen: Shows the current pickup status, battery level, channel, frequency, and other info.
- ② Power/Mute Switch: Press and hold to power on or off. When powered on, press to enable or disable mute mode.
- ③ 4-Pin Mic Input Socket: Used to install or replace the plug-in mic.
- ④ Infrared Sync Window: Used with the receiver's "Sync" button to transmit channel parameters to the transmitter.
- ⑤ Type-C Interface: Use a Type-C charging cable to connect the adapter for mic charging.
- ⑥ Power Indicator Light: During charging, the indicator light shows blue; when fully charged, the indicator light shows green.

■ Operating Instructions

Operating Guide for XC-4R Receiver

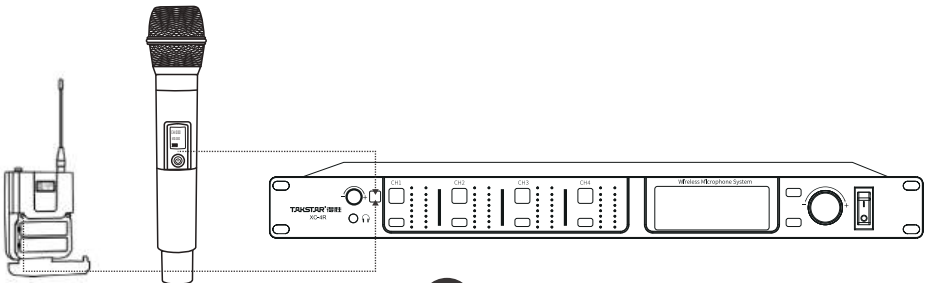

1. Frequency Sync

Power on both the receiver and the transmitter. Align the infrared window of the receiver with that of the transmitter, keeping a distance within 30cm. Press the "Sync" button on the receiver corresponding to the desired frequency channel to enter the sync mode. Once the frequencies of the transmitter and receiver are matched, the receiver will display RF indication and battery level, indicating successful synchronization. Note: If synchronization fails, repeat the above steps.

2. Automatic Interference-Free Frequency Search

When powered on, press and hold the "Scout" button on the receiver for 3 seconds to enter the automatic scanning mode, which quickly and accurately finds interference-free available channels.

3. Frequency Adjustment

Switch to the display of the desired channel, and press the function adjuster on the receiver repeatedly until the channel display area on the screen blinks. Then, rotate the function adjuster to adjust to a desired receiver frequency, and press to confirm and save.

4. Frequency Group Selection

Switch to the display of the desired channel, and press the function adjuster on the receiver repeatedly until the workgroup display area on the screen blinks. Then, rotate the function adjuster to adjust to a desired receiver workgroup, and press to confirm and save.

5. Volume Adjustment

Switch to the display of the desired channel, and press the function adjuster on the receiver repeatedly until the volume display area on the screen blinks. Then, rotate the function adjuster to adjust the volume, and press to confirm and save.

6. System Lock/Unlock

When powered on, press and hold the "Lock" button to lock the receiver. When locked, all function buttons are disabled. Press and hold the "Lock" button again to unlock and restore button functionality.

Operating Guide for XC-TD Handheld Transmitter

1. Press and hold the power switch to turn on the mic. The LCD display screen will light up, showing the current working channel, battery level, and other info.
2. To change the working channel, first change the channel on the receiver, then align the infrared sync window of the transmitter with that on the receiver. Press the "Sync" button on the receiver to transmit the new frequency parameters to the transmitter. (Refer to the receiver's Frequency Adjustment section for details.)

Operating Guide for XC-TP Bodypack Transmitter

1. Battery Installation: Open the battery compartment of the bodypack transmitter and install two AA batteries according to the marked polarity. Ensure that the batteries are inserted correctly and then close the battery compartment.
2. Insert the plug of a headset or lavalier mic into the mic input jack of the transmitter and secure it.
3. Set the power switch of the bodypack transmitter to the "ON" position to power on. Align the infrared receiving window of the transmitter with that of the receiver, keeping a distance within 30cm. Press the "Sync" button on the receiver corresponding to the desired frequency channel for synchronization. (Refer to the receiver's Frequency Adjustment section for details.)
4. Adjust the power level of the transmitter according to actual needs.

Operating Guide for XC-TH Conference Transmitter

1. Install the gooseneck mic into the 4-pin mic input socket of the conference transmitter.
2. Press and hold the power button of the conference transmitter to power on. Align the infrared receiving window of the transmitter with that of the receiver, keeping a distance within 30cm. Press the "Sync" button on the receiver corresponding to the desired frequency channel for synchronization.
3. When the conference transmitter is powered on, press the power button to mute the mic, and the red indicator light will turn off.
4. It is recommended to maintain a pickup distance of approximately 20-50cm during speaking.

■ Troubleshooting

Issues	Causes
No indication on transmitter and receiver	<ul style="list-style-type: none"> - Transmitter battery is depleted. - Ensure proper connection of the receiver power supply.
No RF signal on receiver	Transmitter and receiver are on different frequencies or beyond reception range.
RF signal present, but no audio signal	<ul style="list-style-type: none"> - Mic not connected to transmitter, or receiver squelch set too high. - Faulty audio circuit. - Mute mode activated.
Excessive background noise in audio signal	<ul style="list-style-type: none"> - Transmitter modulation frequency deviation is too small. - Receiver output level is low. - Possible interference signals.
Audio signal distortion	<ul style="list-style-type: none"> - Transmitter modulation frequency deviation is too large. - Receiver output level is too high.
Unstable signal when using at a short distance	<ul style="list-style-type: none"> - Transmitter set to low power. - Receiver squelch set too high. - Improper antenna setup on receiver and strong electromagnetic interference in the surroundings.

■ Safety Instructions

To avoid electric shock, overheat, fire, radiation, explosion, mechanical risk and injury or property loss due to improper use, please read and observe the following items before use:

1. Please check if the power of the connected equipment matches with that of this product before operation. Adjust the volume to proper level during operation. Do not operate at over-power or high-volume level for extended time to avoid product malfunction or hearing impairment.
2. If there is any abnormality during use (e.g., smoke, strange odor), please kill the power switch and unplug from power source, then send the product to the local after-sales service for repair.
3. Never use any replacement battery with broken insulation. Do not charge non-chargeable battery.
4. Dispose waste batteries in designated dustbin for sorting. Do not use them as children's toy nor discard directly to avoid health risk or environmental damage.
5. Keep this product and its accessories in a dry and ventilated area. Do not store in a humid or dusty area for extended time. Keep away from fire, rain, liquid intrusion, bumping, throwing, vibrating, or from blocking any ventilation openings, to prevent malfunction.

6. The product must, when installed on walls or ceilings, be fixed firmly in place at adequate strength to prevent from falling.
7. Please abide by safety rules during operation. Do not use the product in places prohibited by laws or regulations to avoid accident.
8. Do not disassemble or repair the product by yourself to avoid injury. If you have any questions or require any services, please contact our local after-sales service.
9. For optimal performance, please fully charge the lithium-ion battery before its first use.

■ Label Meanings



This symbol indicates that this product should not be disposed of with your household waste, according to the WEEE directive (2012/19/EU) and your national law. This product should be handed over to an authorized collection site for recycling waste electrical and electronic equipment (WEEE). Improper handling of this type of waste could have a possible negative impact on the environment and human health due to potentially hazardous substances that are generally associated with WEEE. At the same time, your cooperation in the correct disposal of this product will contribute to the effective usage of natural resources. For more information about where you can drop off your waste equipment for recycling, please contact your local city office, waste authority, or your household waste disposal service.

■ About This Manual

This manual contains up-to-date technical specifications as of printing. However, specifications contained herein may not conform to your particular product since Takstar is constantly improving its products. Also, specifications, devices or accessories available may vary from region to region. If you have any questions, please contact our local sales outlet. For the latest version/more information, please visit our website: <https://www.takstar.com/>

Copyright ©2024 TAKSTAR. TAKSTAR, 得胜 and their respective logos are registered trademarks or trademarks of Guangdong Takstar Electronic Co., Ltd. in the PRC, and/or other countries. All other trademarks are the property of their respective owners.



扫一扫, 了解更多产品
Scan for more
product information

广东省电声工程技术研究开发中心 广东得胜电子有限公司制造

地址: 广东省惠州市博罗县龙溪街道富康一路2号

服务热线: 400 6828 333 传真: 0752 6383950

邮箱: xs@takstar.com

网址: www.takstar.com

Designed & Manufactured by:

Guangdong Takstar Electronic Co., Ltd.

Address: No.2 Fu Kang Yi Rd., Longxi Boluo
Huizhou, Guangdong 516121 China

Tel: 86 752 6383644 Fax: 86 752 6383952

Email: sales@takstar.com

Website: www.takstar.com