

一. 前言

尊敬的用户：

感谢您选购得胜 ECA-102 双十寸线性阵列音箱，配套 ECA-181 超低音音箱，为了您能够更好的了解使用本产品，建议您在购买前仔细阅读本说明书。

若存在有疑问或者您有宝贵的建议，可通过拨打得胜官方服务热线 400 6828 333 或微信扫描二维码关注得胜官方公众号与我们联系。



二. 产品特性

ECA-102

1. 音箱采用两只 10 寸低音和一只 75 芯压缩磁高音单元，频响范围宽，穿透力强
2. 音箱内外分频设计并配置切换开关，可灵活的选择系统分频方式，系统搭配更自由
3. 箱体表面喷涂聚脲漆，防水防潮抗腐蚀，延长箱体使用寿命的同时满足更多的使用环境
4. 低音采用弹性与耐疲劳性俱佳并附特殊涂层处理的布边折环，中低频反应迅速、动态足
5. 高音采用聚酰亚胺膜片，高频透亮平滑、细腻耐听，细节表现力好
6. 配上特定指向性平面波导号角，能有效控制垂直指向性，多只组合近似线性声源，远距离传播衰减减小
7. 磁路采用对称设计，谐波失真小
8. 分频器元件采用了损耗值较低的无氧空心电感、高品质聚丙烯及聚酯电容，使分频网络稳定，音质出众
9. 箱体采用梯形结构，内壁贴附吸音棉能减少驻波的产生，使中低频在听感上表现得更干净，频响上更平坦；箱体结构紧凑，采用吊挂件连接，配备插销，垂直角度 0° 至 10° 五档可调，可根据场地大小灵活调节辐射角度

ECA-181

1. 音箱采用一只 18 寸钕磁低音单元，重量轻易安装
2. 低音采用弹性与耐疲劳性俱佳并附特殊涂层处理的布边折环，低频饱满，反应迅速、动态足；
3. 磁路采用对称设计，谐波失真小；
4. 箱体表面喷涂聚脲漆，防水防潮抗腐蚀，延长箱体使用寿命的同时满足更多的使用环境
5. 音箱箱体结构方面，采用导相式设计，并在箱体前方增加一开口腔体结构，以达到号角的作用；导相管低频声波与扬声器正面声量叠加后，在前腔体压缩后辐射而出，提高了低频往正前方传输的声能量、并提升了低频声压和力度

三. 音箱与功放连接示意图

图 1

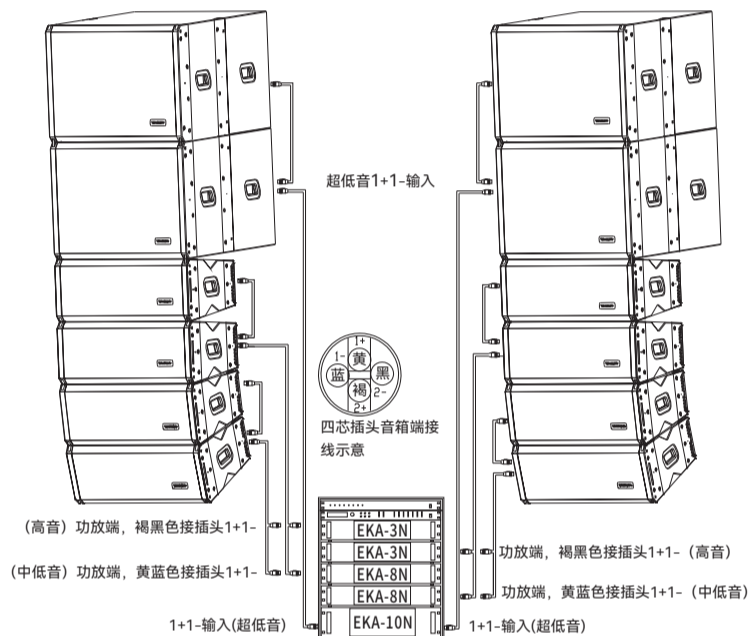

外置分频模式 (BIAMP)

1. 左、右声道各两只超低音、四只线性阵列全频音箱。超低音箱每只 8Ω，用连接线连接两只超低音，并联后总阻抗值 4Ω。全频音箱每两只音箱连接一条连接线，并联后，低音和高音分别是阻抗值为 4Ω
2. 采用两台 300W 二通道功放(拨到单通道档位)，一台用于左声道高音，一台用于右声道高音；两台 800W 二通道功放(单通道档位)，一台用于左声道中低音，一台用于右声道中低音；一台 1000W 二通道功放(立体声档位)用于四只超低音音箱。
3. 超低音配二芯音箱线，两端接音箱插头的 1+、1-，黑色对应 1-。
4. 全频音箱的音箱线必须使用四芯音箱电缆线接四芯插头，例如四芯线内有褐、黑、黄、蓝四种颜色，每两种颜色线为一组(若线材实际颜色与说明书不同，取任意两色为一组)，例如黄、蓝色线分别接插头的 1+、1- (用于接中低音)，褐、黑色线接 2+、2- (用于高音)，每条线统一接法，若接错，音箱音质不正常的同时存在导致烧毁高音扬声器的可能。以上是音箱线接音箱的一端。

内置分频模式 (PASSIVE)

1. 左、右声道各两只超低音、四只线性阵列全频音箱。超低音箱每只 8Ω，用连接线连接两只超低音，并联后总阻抗值 4Ω。全频音箱每两只音箱连接一条连接线，并联后总阻抗值 4Ω
2. 超低音使用二芯音箱线，两端接音箱插头的 1+、1-，黑色对应 1-。
3. 全频音箱的音箱线使用二芯音箱线，两端接音箱插头的 1+、1-，黑色对应 1-

图 2: (系统连接示意图)



图 3:



图 4:

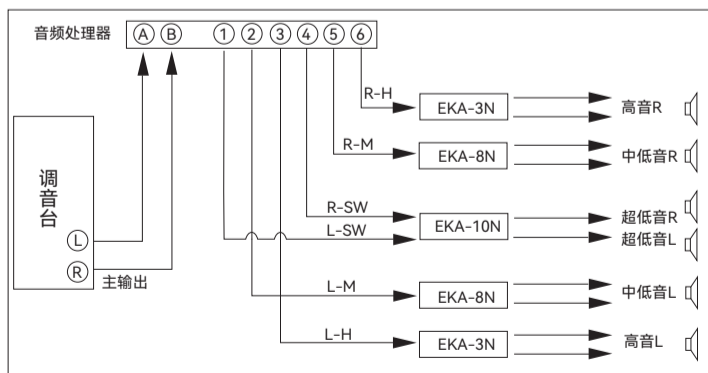

5. 两种不同安装方式的覆盖角度示意图 (如图 3、图 4)。

四. 注意事项

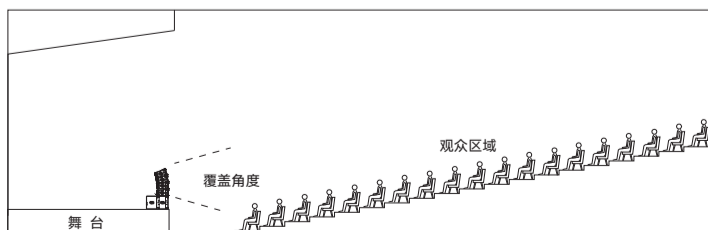
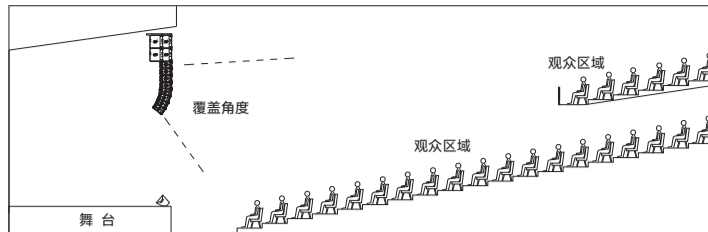
1. 确保功率放大器和音箱的功率、阻抗相匹配，失衡搭配可导致扬声器损坏或损坏音质。
2. 音箱吊挂或倒置于舞台使用时，全频音箱必须调成弧形面，具体弧度视现场而定 (如图 3、图 4)
3. 音箱的安装需由专业工程人员进行，应固定牢靠。
4. 搬运音箱时，请小心轻放，保护好音箱不受损坏。
5. 非专业技术人员请勿私自接线或使用设备。
6. 系统的音质效果取决于调试者的专业技术、音乐鉴赏水平等综合能力。
7. 音箱使用完后，音箱上的插销、连接杆固定在音箱上，以免丢失。
8. 该线性阵列音箱推荐最大吊挂数量为 4 只 ECA-181+8 只 ECA-102。

五. 技术参数

类别	项目	超低音	中低音扬声器	高音
扬声器参数	外径	18寸	10寸	120mm
	音圈直径	100mm	65mm	75mm
	磁钢	钕铁硼	铁氧体156mm	钕铁硼
	灵敏度	104dB	104dB	112dB
	额定阻抗	8Ω	16Ω	8Ω
	频率响应	38Hz-500Hz	65Hz-2kHz	900Hz-20kHz
音箱参数	音箱型号	ECA-181	ECA-102	
	用量	1PCS	2PCS	1PCS
	音箱阻抗	8Ω	8Ω	8Ω
	指向性	无	H100° x V10°	
	外置分频额定功率(AES)	1000W	600W	180W
	内置分频额定功率(AES)		800W	
	匹配功放	1000W*2 两只音箱并联	600W*2 两只音箱并联	300W*2 两只音箱并联
	内置分频频率范围	38Hz-80Hz		
	外置分频范围	38Hz-80Hz	80Hz-1.87KHz	1.9KHz-20KHz
	外置滤波选择	高通BW-42、低通BW-42	高通BW-48、低通BW-48	高通BW-36、低通BYPASS
	表面处理	黑色聚脲漆		
	安装方式	吊挂件连接	吊挂件连接，垂直角度0°-10°五档可调	
板材	18mm夹板	15mm夹板		
尺寸	640*685*585mm (W*D*H)	640*410*310 (W*D*H)		
净重	46.1KG	27.1KG		
接线方式	2PCS, IN:1+/1-	内置分频 (IN:1+/1-)，外置分频 (IN:中低音1+/1-，高音2+/2-)		
线材	两芯音频电缆线	内置分频 (两芯音频电缆线)，外置分频 (四芯音频电缆线)		

注：以上数据由得胜实验室测试得到，并拥有最终解释权！

六. 标准配置

田字架 (每只含U型扣4只, 插销4只, 吊带2条, 连接杆4条), 每列线性阵列音箱配一只田字架
全频音箱 (每只含前后连接杆共4条, 插销4只)
超低音音箱 (每只含前后连接杆共4条, 插销4只)
说明书

备注：视每次订单数量或使用数量而定，出厂前填写以上数据。

七. 安全警示

为避免电击、高温、着火、辐射、爆炸、机械危险以及使用不当等可能造成的人身伤害或财产损失，使用本产品，请仔细阅读并遵守以下事项：

1. 使用产品时请确认所连接设备与本产品功率是否匹配以及合理调整音量大小，不要在超过产品功率及大音量下长时间使用，以免造成产品异常和听力损伤；
2. 使用中若发现有异常(如冒烟、异味等)，请立即关闭电源开关并拔掉电源插头，然后将产品送经销商检修；
3. 本产品及配件都应放置在室内干燥通风处，勿长期存放在潮湿、灰尘多的环境，使用中避免靠近火源、雨淋、进水、过度碰撞、抛掷、振动本机及覆盖通风孔，以免损坏其功能；
4. 若产品需要固定于墙壁或天花板上时，请确保固定到位，防止因固定强度不足导致产品发生跌落危险；
5. 使用该产品时需遵守相关安全规定，法律法规明确禁止使用场合请勿使用本机，以免导致意外事故；
6. 请不要自行拆机改装或维修，以防止出现人身伤害，如有问题或服务需求请联系当地经销商跟进处理。

注意事项:

1. 本单为保修凭证，请用户妥善保管，如有遗失，恕不保修或退换。
2. 保修期限制：购买之日起十二个月内。
3. 除了不可抗力事件损坏外，由本公司负责，免费维修。
4. 如属保管不善或使用不当造成的损坏，维修点将酌情收费。
5. 擅自拆卸维修者，不予保修。
6. 以上保修条款仅限于中国市场适用 (不含港澳台地区)。

产品服务保证书

姓名: _____ 电话: _____ 地址: _____
商品: _____ 型号: _____ 购买日期: _____ 年 _____ 月 _____ 日

维修记录栏 (由维修员填写)	维修员签名	日期

◆广东得胜电子有限公司 ◆电话: 400-6828-333 ◆地址: 广东省惠州市博罗县龙溪街道富康一路2号



I. Preface

Dear Customer,
Thank you for purchasing Takstar ECA-102 Dual 10" Line Array Speaker, paired with the ECA-181 Subwoofer. To better understand and use the product, please read this manual thoroughly. If you have any questions or suggestions, please contact our local sales outlet.

II. Features

ECA-102

- Two 10-inch woofers and one 75-mm neodymium compression tweeter for wide frequency response and strong propagation.
- Switchable crossover design allows flexible system setup.
- Waterproof, weatherproof and corrosion resistant PU coating to extend lifespan in various environments.
- Woofers with specially-coated elastomer surround produces quick mid-bass response.
- Polyimide dome tweeter delivers precise, smooth highs.
- Waveguide horn controls vertical dispersion for linear sound source over distance.
- Symmetrical magnetics minimize harmonic distortion.
- Crossover uses low-loss components like OFC air-core inductors, PET and CBB capacitors for stable, quality sound.
- Trapezoidal enclosure with interior sound-absorbing material that reduces standing waves and improves mid-bass performance. Compact, rigid design connects securely with swivel brackets and adjustable 0-10° vertical angle in five steps.

ECA-181

- 18-inch neodymium driver produces deep bass with lightweight enclosure.
- Durable elastomer surround with special coating produces quick, impactful lows.
- Symmetrical magnetics minimize harmonic distortion.
- Waterproof, weatherproof and corrosion resistant PU coating to extend lifespan in various environments.
- Reflex port design focuses LF energy to the front, increasing LF output, pressure and impact.

III. Wiring Speaker & Power Amp

Fig. 1

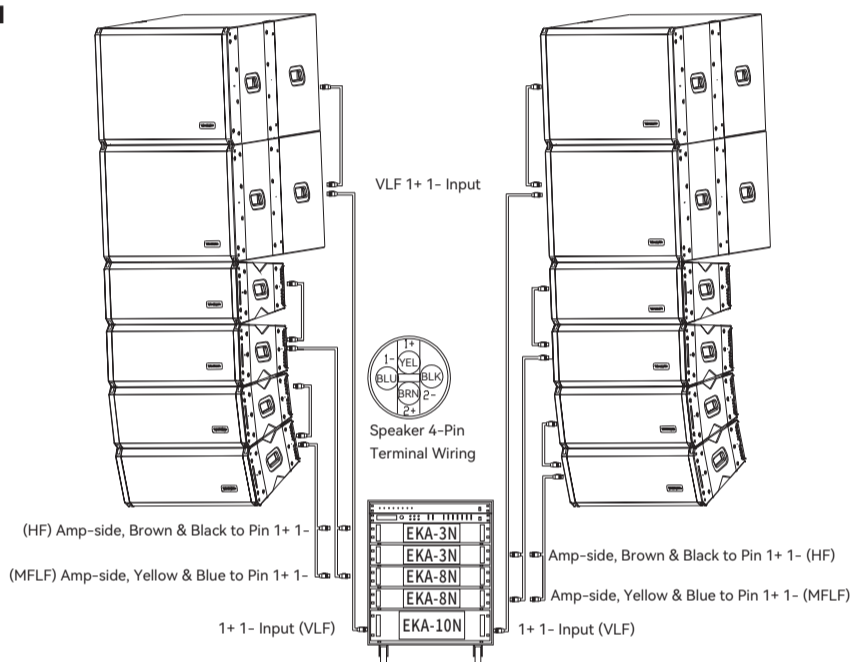

External Crossover Mode (BIAMP)

- Left and right channels each with 2 subwoofers and 4 full-range speakers. Each subwoofer is 8 Ω, connect pairs in parallel for 4 Ω total impedance. And connect remaining four full-range speakers in pairs in parallel for 4 Ω LF and HF driver impedance.
- Use the following power amplifiers: Two 300W 2-channel amplifiers (mono mode) for left and right highs (HF). Two 800W 2-channel amplifiers (mono mode) for left and right mids/lows (MFLF). One 1000W 2-channel amplifier (stereo mode) for all four subwoofers.
- Subwoofers use two-core audio cable connected to speaker terminal Pin 1+/-, with black wire to 1-.
- Full-range speaker must use four-core cables with 4-pin connector. For example, if the four cores are of brown, black, yellow and blue colors, use two colors as a pair (choose any two colors in pairs if different from the example here). Say, yellow & blue wires each to connector Pin 1+/- (for MFLF), brown & black to Pin 2+/- (for HF), and follow the same color-combination wiring across all speakers. Make sure to connect the cables correctly to avoid damaging the speakers or amplifier.

Internal Crossover Mode (PASSIVE)

- Left and right channels each with 2 subwoofers and 4 full-range speakers. Each subwoofer is 8 Ω, connect pairs in parallel for 4 Ω total impedance. And connect full-range speaker in pairs in parallel for 4 Ω total impedance per side.
- Subwoofers use two-core audio cable connected to speaker terminal Pin 1+/-, with black wire to 1-.
- Full-range speakers use two-core cable connected to speaker terminal Pin 1+/-, with black wire to 1-.

Fig. 2: (System Connection Diagram)

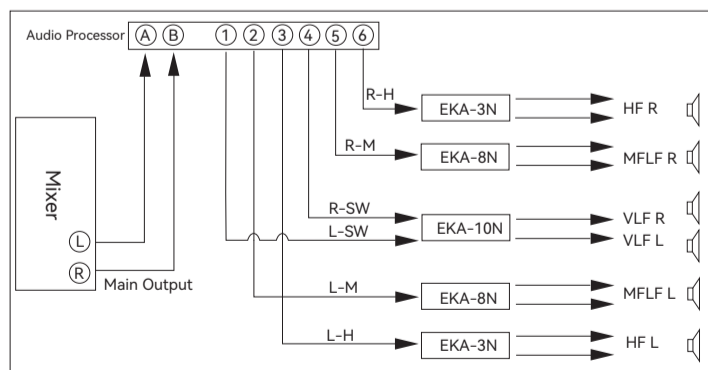

Fig. 3:

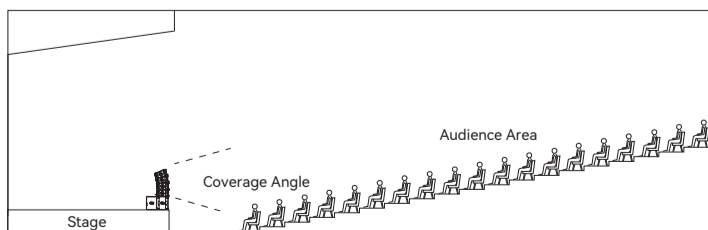
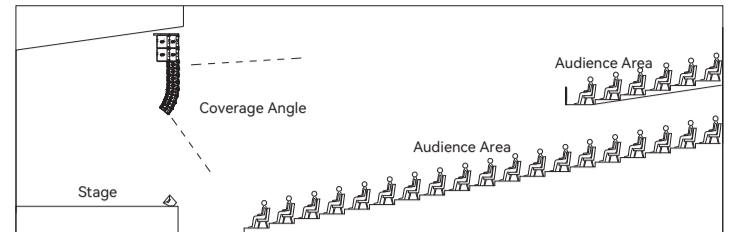

Fig. 4:



- Coverage angle of two different installation methods as shown in Figs. 3-4.

IV. Cautions

- Match amplifier power and impedance to speakers to prevent equipment damage or degraded sound quality.
- For suspended or inverted stage installation, adjust full-range speakers to required curvature (Figs. 3-4).
- Secure speakers firmly in place by qualified installers.
- Handle speakers carefully to prevent transport damage.
- Leave wiring and setup to qualified technicians.
- System sound depends on the tuning skills of the technician.
- Secure pins and fasteners after use to prevent loose or lost parts.
- Recommended maximum suspended configuration is 4 ECA-181 subwoofers plus 8 ECA-102 full-range speakers.

V. Specifications

Type	Item	VLF (Subwoofer)	MFLF (Woofer)	HF (Tweeter)
Driver Spec	Outer Diameter	18"	10"	120mm
	Voice Coil Diameter	100mm	65mm	75mm
	Magnet	NdFeB	Ferrite 156mm	NdFeB
	Sensitivity	104dB	104dB	112dB
	Rated Impedance	8Ω	16Ω	8Ω
	Frequency Response	38Hz-500Hz	65Hz-2kHz	900Hz-20kHz
Speaker Spec	Model	ECA-181	ECA-102	
	Quantity	1PCS	2PCS	1PCS
	Impedance	8Ω	8Ω	8Ω
	Directivity	/	H100° x V10°	
	Ext Xover Rating (AES)	1000W	600W	180W
	Int Xover Rating (AES)		800W	
	Amp Match	1000W * 2, two speakers in parallel	600W * 2, two speakers in parallel	300W * 2, two speakers in parallel
	Int Xover Range	38Hz-80Hz	65Hz-20KHz	
	Ext Xover Range	38Hz-80Hz	80Hz-1.87KHz	1.9KHz-20KHz
	Ext Filter	High Pass BW-42, Low Pass BW-42	High Pass BW-48, Low Pass BW-48	High Pass BW-36, Low Pass Bypass
	Finish	Black Polyurethane Paint		
	Installation	Suspension Bracket	Suspension Bracket, 0-10° Vertical Angle Adjust (5 Steps)	
	Panel	18mm Plywood	15mm Plywood	
	Dimensions	640*685*585mm (W*D*H)	640*410*310 (W*D*H)	
	Net Weight	46.1KG	27.1KG	
	Wiring	2PCS,IN:1+/-	Int Xover (IN: 1+/-); Ext Xover (IN: MFLF 1+/-, HF 2+/-)	
Audio Cable	Two-Core Cable	Int Xover (Two-Core Cable); Ext Xover (Four-Core Cable)		

Note: The above data are measured by Takstar laboratory which has the final interpretation right!

VI. Standard Configuration

Rigging Frames: Each frame includes 4 U-shaped brackets, 4 quick-release pins, 2 suspension straps, and 4 connecting rods. Each column of line array speakers is supplied with one rigging frame.

Full-Range Speakers: Each speaker includes a total of 4 front and rear connecting rods and 4 quick-release pins.

Subwoofer Speakers: Each speaker includes a total of 4 front and rear connecting rods and 4 quick-release pins.

User Manual

Note: The above data will be filled out prior to shipment, depending on the quantity or intended usage specified in each order.

VII. Safety Instructions

To avoid electric shock, overheating, fire, radiation, explosion, mechanical risk and injury or property loss due to improper use, please read and observe the following items before use:

- Please check if the power of the connected equipment matches with that of this product before operation. Adjust the volume to proper level during operation. Do not operate at over-power or high-volume level for extended time to avoid product malfunction or hearing impairment.
- If there is any abnormality during use (e.g., smoke, strange odor), please kill the power switch and unplug from power source, then send the product to the local after-sales service for repair.
- Keep this product and its accessories in a dry and ventilated area. Do not store in a humid or dusty area for extended time. Keep away from fire, rain, liquid intrusion, bumping, throwing, vibrating, or from blocking any ventilation openings, to prevent malfunction.
- The product must, when installed on walls or ceilings, be fixed firmly in place at adequate strength to prevent from falling.
- Please abide by safety rules during operation. Do not use the product in places prohibited by laws or regulations to avoid accident.
- Do not disassemble or repair the product by yourself to avoid injury. If you have any questions or require any services, please contact our local after-sales service.